

Service Manual



AWG2021 Arbitrary Waveform Generator

070-9098-08

Warning

The servicing instructions are for use by qualified personnel only. To avoid personal injury, do not perform any servicing unless you are qualified to do so. Refer to the Safety Summary prior to performing service.



Copyright © Sony/Tektronix Corporation. All rights reserved.

Copyright © Tektronix, Inc. All rights reserved.

Tektronix products are covered by U.S. and foreign patents, issued and pending. Information in this publication supercedes that in all previously published material. Specifications and price change privileges reserved.

Printed in Japan.

Sony/Tektronix Corporation, P.O.Box 5209, Tokyo Int'l, Tokyo 100-31 Japan

Tektronix, Inc., P.O. Box 1000, Wilsonville, OR 97070-1000

TEKTRONIX and TEK are registered trademarks of Tektronix, Inc.

WARRANTY

Tektronix warrants that this product will be free from defects in materials and workmanship for a period of one (1) year from the date of shipment. If any such product proves defective during this warranty period, Tektronix, at its option, either will repair the defective product without charge for parts and labor, or will provide a replacement in exchange for the defective product.

In order to obtain service under this warranty, Customer must notify Tektronix of the defect before the expiration of the warranty period and make suitable arrangements for the performance of service. Customer shall be responsible for packaging and shipping the defective product to the service center designated by Tektronix, with shipping charges prepaid. Tektronix shall pay for the return of the product to Customer if the shipment is to a location within the country in which the Tektronix service center is located. Customer shall be responsible for paying all shipping charges, duties, taxes, and any other charges for products returned to any other locations.

This warranty shall not apply to any defect, failure or damage caused by improper use or improper or inadequate maintenance and care. Tektronix shall not be obligated to furnish service under this warranty a) to repair damage resulting from attempts by personnel other than Tektronix representatives to install, repair or service the product; b) to repair damage resulting from improper use or connection to incompatible equipment; or c) to service a product that has been modified or integrated with other products when the effect of such modification or integration increases the time or difficulty of servicing the product.

THIS WARRANTY IS GIVEN BY TEKTRONIX WITH RESPECT TO THIS PRODUCT IN LIEU OF ANY OTHER WARRANTIES, EXPRESSED OR IMPLIED. TEKTRONIX AND ITS VENDORS DISCLAIM ANY IMPLIED WARRANTIES OF MERCHANTABILITY OR FITNESS FOR A PARTICULAR PURPOSE. TEKTRONIX' RESPONSIBILITY TO REPAIR OR REPLACE DEFECTIVE PRODUCTS IS THE SOLE AND EXCLUSIVE REMEDY PROVIDED TO THE CUSTOMER FOR BREACH OF THIS WARRANTY. TEKTRONIX AND ITS VENDORS WILL NOT BE LIABLE FOR ANY INDIRECT, SPECIAL, INCIDENTAL, OR CONSEQUENTIAL DAMAGES IRRESPECTIVE OF WHETHER TEKTRONIX OR THE VENDOR HAS ADVANCE NOTICE OF THE POSSIBILITY OF SUCH DAMAGES.

Table of Contents

General Safety Summary	ix
Service Safety Summary	xi
Preface	xiii
Introduction	xv

Specifications

Product Description	1-1
Performance Characteristics	1-3
Performance Conditions	1-3
Introduction	1-3
Nominal Traits	1-4
Warranted Characteristics	1-9
Typical Characteristics	1-15

Operating Information

Preparation for Use	2-1
Supplying Power	2-1
Power Cord Information	2-2
Operating Environment	2-4
Operating Temperature	2-4
Ventilation Requirements	2-4
Rear Panel Controls	2-4
Fuse Type and Rating	2-5
Applying and Interrupting Power	2-6
Power-on Cycle	2-6
Power-off Cycle	2-6
Memory Backup Power	2-7
Repackaging Instructions	2-7
Installed Options	2-8
Operating Instructions	2-9
How to Power On	2-9
Internal Diagnostics and Calibration Routines	2-9
User Interface	2-10
Display	2-10
Menus	2-12
Waveform Files	2-13
Waveform Storage and I/O	2-14
Loading Files	2-14
Setting Output Parameters	2-15
Operation Mode Settings	2-17

Theory of Operation

Module Overview	3-1
Clock Synthesizer (A10, Synthesizer Board)	3-1
CH1/CH2 Clock Divider (A21/A31, Control Board)	3-1
Waveform Memory Control (A21, Control Board)	3-1
Waveform Memory (A21, Control Board)	3-1
Digital-to-Analog Converter (DAC) (A21, Control Board)	3-2
Analog Processing (A3, Analog Board)	3-2
CPU and Memory (A6, CPU Board)	3-2
GPIB (A6, CPU Board)	3-2
RS-232-C (A6, CPU Board)	3-2
Display Control (A6, CPU Board)	3-2
Display Monitor	3-2
Front Panel (A12, Keyboard)	3-2
Floppy Disk Drive	3-3
Low Voltage Power Supply (A4 Power Board)	3-3
Fan	3-3
Options	3-3

Performance Verification

Performance Verification Procedures	4-1
Preparation	4-1
Conventions	4-1
Self Tests	4-3
Diagnostics	4-3
Calibration	4-5
Performance Tests	4-7
Prerequisites	4-7
Related Information	4-8
Equipment Required	4-8
Performance Check/Adjustment Files	4-9
Operating Mode Checks	4-12
Arithmetic Operation Checks	4-25
Clock Frequency and Amplitude Checks	4-30
Gain and Offset Accuracy Checks	4-34
Pulse Response Check	4-37
SYNC Out and MARKER Out Amplitude Checks	4-40
External Trigger Level Accuracy Check	4-42
External CLOCK IN Check	4-45
ECL Digital Data Out Check (Option 03)	4-47
TTL DIGITAL DATA OUT Check (Option 04)	4-51
Floating Point Processor Check (Option 09)	4-54

Adjustment Procedures

Adjustment Procedures	5-1
Requirements for Performance	5-1
Equipment Required	5-2
Before Adjustments	5-2
Providing Access	5-2
Cooling	5-3
Performance Check/Adjustment Files	5-4
Adjustments	5-5
X5 Amplifier HF Compensation	5-5

Maintenance

Maintenance	6-1
Preparation	6-1
Preventing ESD	6-2
Inspection and Cleaning	6-4
General Care	6-4
Removal and Installation Procedures	6-9
Preparation	6-9
List of Mechanical Parts	6-9
General Instructions	6-9
Summary of Procedures	6-10
Equipment Required	6-10
AWG2021 Orientation	6-11
Access Procedure	6-12
Procedures for External Modules	6-15
Front-panel Knob	6-16
Line Fuse and Line Cord	6-17
Rear Cover and Cabinet	6-18
EMI Gaskets	6-20
Front Cover, Trim Ring, and Menu Buttons	6-20
Front-panel Module	6-22
Procedures for Internal Modules	6-26
A4 Power Board, A3 Analog Board, and A23 Analog Board (Option 02)	6-27
Connector Module	6-30
Fan and Fan Frame	6-31
Rear Shield Cover	6-33
Rear BNC Connector	6-34
Power Supply Module	6-35
AC Inlet and AUX Power Board	6-37
Monitor Module and CRT Frame	6-39
Circuit Boards	6-42
A5 Backplane Board	6-46
Lithium Battery	6-48
Floppy-disk Drive Module	6-49
Troubleshooting	6-53
After Repair Adjustment	6-53
Troubleshooting Procedures	6-53
AWG2021 Diagnostics	6-53
Checking Diagnostics Tests	6-54

Options

Options and Accessories	7-1
List of Options	7-1
Options A1–A5	7-2
Option 02 Description	7-2
Option 03 Description	7-2
Data Output	7-2
Clock Output	7-2
Output Connector Configuration	7-4
Operation	7-5
Output Circuit and Output Waveform	7-6
Application Suggestions	7-8
Option 04 Description	7-11
Data Output	7-11
Clock Output	7-11
Output Connector Configuration	7-12
Operation	7-12
Output Circuit and Output Waveform	7-13
Application Example	7-15
Waveform Regeneration	7-16
Option 09 Description	7-17
Option 1R Description	7-17
Option 1S Description	7-17
Option 95 Description	7-17
Accessories	7-18
Standard Accessories	7-18
Optional Accessories	7-18

Replaceable Electrical Parts

Electrical Parts List	8-1
------------------------------------	------------

Diagrams

Diagrams	9-1
-----------------------	------------

Replaceable Mechanical Parts

Replaceable Mechanical Parts	10-1
Using the Replaceable Parts List	10-2

List of Figures

Figure 1–1: Timing for the Data and Clock Signals	1–11
Figure 2–1: Rear Panel Controls	2–5
Figure 2–2: Display Features	2–11
Figure 2–3: LOAD Menu	2–15
Figure 2–4: SETUP Menu	2–16
Figure 2–5: MODE Menu	2–18
Figure 4–1: Diagnostics Menu	4–4
Figure 4–2: Calibrations Menu	4–5
Figure 4–3: Cont Mode Initial Test Hookup	4–12
Figure 4–4: Triggered Mode Initial Test Hookup	4–14
Figure 4–5: Burst Mode Initial Test Hookup	4–16
Figure 4–6: Gated Mode Initial Test Hookup	4–18
Figure 4–7: Relationship Between 1 Volt or Greater Gate Signal and Waveform Output Signal	4–20
Figure 4–8: Waveform Advance Mode Initial Test Hookup	4–21
Figure 4–9: Autostep Mode Initial Test Hookup	4–23
Figure 4–10: External AM Operation Initial Test Hookup	4–26
Figure 4–11: MODE Menu Autostep Setting	4–27
Figure 4–12: Clock Frequency Accuracy Initial Test Hookup	4–30
Figure 4–13: Clock Amplitude Initial Test Hookup	4–32
Figure 4–14: Gain Accuracy Initial Test Hookup	4–34
Figure 4–15: Pulse Response Initial Test Hookup	4–37
Figure 4–16: Initial Test Hookup	4–40
Figure 4–17: External Trigger Level Accuracy Initial Test Hookup	4–42
Figure 4–18: External CLOCK IN Initial Test Hookup	4–45
Figure 4–19: ECL Digital Data Out Initial Test Hookup	4–48
Figure 4–20: Output Pins on the Termination Board	4–50
Figure 4–21: TTL Digital Data Out Initial Test Hookup	4–51
Figure 4–22: Output Pins on the TTL Digital Data Out Cable	4–53
Figure 5–1: Cooling the AWG2021 During Adjustment Procedures	5–3
Figure 5–2: Hookup for X5 Amplifier HF Compensation	5–5
Figure 5–3: C201 Locations for CH1 and CH2	5–7

Figure 5–4: Hookup for Attenuator LF Compensation	5–8
Figure 5–5: PELTOLA Cable with BNC	5–8
Figure 5–6: C301 Location	5–9
Figure 6–1: AWG2021 Orientation	6–11
Figure 6–2: Guide to Removal Procedures	6–12
Figure 6–3: External Modules	6–13
Figure 6–4: Internal Modules	6–14
Figure 6–5: Front-panel Knob Removal	6–16
Figure 6–6: Line Fuse and Line Cord Removal	6–17
Figure 6–7: Rear Cover and Cabinet Removal	6–19
Figure 6–8: Front Cover, Trim Ring, and Menu Button Removal (Front Cover not Shown)	6–21
Figure 6–9: Front-panel Module Removal	6–23
Figure 6–10: A12 Keyboard Removal	6–24
Figure 6–11: Disassembly of Front-panel Module	6–25
Figure 6–12: A4 Power Board Removal	6–27
Figure 6–13: A3/A23 Analog Board Removal	6–29
Figure 6–14: Connector Module Removal	6–30
Figure 6–15: Fan and Fan Frame Removal	6–32
Figure 6–16: Rear Shield Cover Removal	6–33
Figure 6–17: Rear BNC Connector Removal	6–35
Figure 6–18: Power Supply Module Removal	6–36
Figure 6–19: AUX Power Board and AC Inlet Removal	6–38
Figure 6–20: Monitor Module Removal	6–40
Figure 6–21: CRT Frame Removal	6–41
Figure 6–22: Board Removal	6–45
Figure 6–23: A5 Backplane Board Removal	6–47
Figure 6–24: Battery Location on the A5 Backplane Board	6–49
Figure 6–25: Floppy-disk Drive Module Removal	6–51
Figure 6–26: A6 CPU Board	6–54
Figure 6–27: Primary Troubleshooting Procedure	6–55
Figure 6–28: Troubleshooting Procedure 1 — Power Supply Module	6–56
Figure 6–29: AUX Power Board	6–57
Figure 6–30: Power Supply Module	6–57
Figure 6–31: A10 Synthesizer Board	6–58
Figure 6–32: A3/A23 Analog Board	6–58
Figure 6–33: Troubleshooting Procedure 2 — A6 CPU Board or Front-panel Module	6–59
Figure 6–34: Key Board	6–60

Figure 6–35: Troubleshooting Procedure 3 — Monitor Module	6–61
Figure 6–36: Monitor Module	6–62
Figure 6–37: Horizontal and Vertical Sync Signals	6–62
Figure 6–38: A Video Signal with White and Black Levels	6–63
Figure 6–39: Troubleshooting Procedure 4 — Module Isolation	6–64
Figure 7–1: Option 03 Block Diagram	7–3
Figure 7–2: Option 03 Output Connector	7–4
Figure 7–3: Generation of Excess Output	7–5
Figure 7–4: Output Circuit	7–6
Figure 7–5: Output Waveform	7–7
Figure 7–6: Data Latching	7–7
Figure 7–7: Coaxial Cable End Processing	7–8
Figure 7–8: Cable Examples	7–9
Figure 7–9: Digital Data Latch Example	7–10
Figure 7–10: Block Diagram	7–11
Figure 7–11: Option 04 Output Connector	7–12
Figure 7–12: Generation of Excess Output	7–13
Figure 7–13: Output Circuit	7–13
Figure 7–14: Output Waveform	7–14
Figure 7–15: Data Latching	7–14
Figure 7–16: Digital Data Out Cable	7–15
Figure 7–17: Example of Waveform Reproduction Circuit	7–16
Figure 9–1: Block Diagram of AWG2021 with Options 02 and 09 . . .	9–3
Figure 9–2: Block Diagram of AWG2021 with Options 02 and 03 . . .	9–4
Figure 9–3: Block Diagram of AWG2021 with Options 02 and 04 . . .	9–5
Figure 9–4: Interconnect Diagram of AWG2021 with Options 02, 04, and 09	9–6
Figure 9–5: Interconnect Diagram of AWG2021 Option 03	9–7
Figure 10–1: Cabinet	10–5
Figure 10–2: Main Chassis and CRT	10–7
Figure 10–3: Main Chassis and Circuit Boards	10–9
Figure 10–4: Circuit Boards	10–11
Figure 10–5: Front Panel Assembly	10–13
Figure 10–6: Option 02	10–15
Figure 10–7: Option 03	10–17
Figure 10–8: Option 04	10–19
Figure 10–9: Option 09	10–20

List of Tables

Table 1–1: Electrical Characteristics	1–4
Table 1–2: Mechanical Characteristics	1–8
Table 1–3: Electrical Characteristics	1–9
Table 1–4: Environmental Characteristics	1–14
Table 1–5: Electrical Characteristics	1–15
Table 1–6: Certifications and Compliances	1–15
Table 2–1: Power-Cord Conductor Identification	2–2
Table 2–2: Power Cord Identification	2–3
Table 2–3: Fuse Type and Rating	2–5
Table 4–1: Test Equipment	4–8
Table 4–2: File List for Performance Check/Adjustment Disk	4–10
Table 4–3: Clock Frequency Accuracy	4–31
Table 5–1: Test Equipment	5–2
Table 5–2: File List for Performance Check/Adjustment Disk	5–4
Table 6–1: Relative Susceptibility to Static-Discharge Damage	6–3
Table 6–2: External Inspection Check List	6–5
Table 6–3: Internal Inspection Check List	6–6
Table 6–4: Equipment Required	6–10
Table 6–5: Secondary Power Supply Voltages	6–58
Table 7–1: International Power Cords	7–2
Table 7–2: Option 03 Digital Output Signals	7–4
Table 7–3: Option 04 Connector Pin Assignments	7–12
Table 7–4: Standard Accessories List	7–18
Table 7–5: Optional Accessories List	7–18
Table 7–6: Maintenance Kit Contents	7–19

General Safety Summary

Review the following safety precautions to avoid injury and prevent damage to this product or any products connected to it.

Only qualified personnel should perform service procedures.

Injury Precautions

- | | |
|---|--|
| Use Proper Power Cord | To avoid fire hazard, use only the power cord specified for this product. |
| Avoid Electric Overload | To avoid electric shock or fire hazard, do not apply a voltage to a terminal that is outside the range specified for that terminal. |
| Ground the Product | This product is grounded through the grounding conductor of the power cord. To avoid electric shock, the grounding conductor must be connected to earth ground. Before making connections to the input or output terminals of the product, ensure that the product is properly grounded. |
| Do Not Operate Without Covers | To avoid electric shock or fire hazard, do not operate this product with covers or panels removed. |
| Use Proper Fuse | To avoid fire hazard, use only the fuse type and rating specified for this product. |
| Do Not Operate in Wet/Damp Conditions | To avoid electric shock, do not operate this product in wet or damp conditions. |
| Do Not Operate in Explosive Atmosphere | To avoid injury or fire hazard, do not operate this product in an explosive atmosphere. |

Product Damage Precautions

- | | |
|---|---|
| Use Proper Power Source | Do not operate this product from a power source that applies more than the voltage specified. |
| Provide Proper Ventilation | To prevent product overheating, provide proper ventilation. |
| Do Not Operate With Suspected Failures | If you suspect there is damage to this product, have it inspected by qualified service personnel. |

Safety Terms and Symbols

Terms in This Manual These terms may appear in this manual:



WARNING. *Warning statements identify conditions or practices that could result in injury or loss of life.*



CAUTION. *Caution statements identify conditions or practices that could result in damage to this product or other property.*

Terms on the Product These terms may appear on the product:

DANGER indicates an injury hazard immediately accessible as you read the marking.

WARNING indicates an injury hazard not immediately accessible as you read the marking.

CAUTION indicates a hazard to property including the product.

Symbols on the Product The following symbols may appear on the product:



DANGER
High Voltage



Protective Ground
(Earth) Terminal



ATTENTION
Refer to
Manual



Double
Insulated

Certifications and Compliances

CSA Certified Power Cords

CSA Certification includes the products and power cords appropriate for use in the North America power network. All other power cords supplied are approved for the country of use.

Service Safety Summary

Only qualified personnel should perform service procedures. Read this *Service Safety Summary* and the *General Safety Summary* before performing any service procedures.

Do Not Service Alone Do not perform internal service or adjustments of this product unless another person capable of rendering first aid and resuscitation is present.

Disconnect Power To avoid electric shock, disconnect the main power by means of the power cord or, if provided, the power switch.

Use Caution When Servicing the CRT To avoid electric shock or injury, use extreme caution when handling the CRT. Only qualified personnel familiar with CRT servicing procedures and precautions should remove or install the CRT.

CRTs retain hazardous voltages for long periods of time after power is turned off. Before attempting any servicing, discharge the CRT by shorting the anode to chassis ground. When discharging the CRT, connect the discharge path to ground and then the anode. Rough handling may cause the CRT to implode. Do not nick or scratch the glass or subject it to undue pressure when removing or installing it. When handling the CRT, wear safety goggles and heavy gloves for protection.

Use Care When Servicing With Power On Dangerous voltages or currents may exist in this product. Disconnect power, remove battery (if applicable), and disconnect test leads before removing protective panels, soldering, or replacing components.

To avoid electric shock, do not touch exposed connections.

X-Radiation To avoid x-radiation exposure, do not modify or otherwise alter the high-voltage circuitry or the CRT enclosure. X-ray emissions generated within this product have been sufficiently shielded.

Preface

This is the service manual for the AWG2021 Arbitrary Waveform Generator. The manual contains information needed to service the AWG2021 to the module level.

Manual Structure

This manual is divided into sections, such as *Specifications* and *Theory of Operation*. Further, some sections are divided into subsections, such as *Product Description* and *Removal and Installation Procedures*.

Sections containing procedures also contain introductions to those procedures. Be sure to read these introductions because they provide information needed to do the service correctly and efficiently. The following contains a brief description of each manual section.

- *Specifications* contains a description of the AWG2021 and the characteristics that apply to it.
- *Operating Information* includes general information and operating instructions at the level needed to safely power on and service the AWG2021.
- *Theory of Operation* contains circuit descriptions that support general service to the module level.
- *Performance Verification* contains a collection of procedures for confirming that the AWG2021 functions properly and meets warranted limits.
- *Adjustment Procedures* contains a collection of procedures for adjusting the AWG2021 to meet warranted limits.
- *Maintenance* contains information and procedures for performing preventive and corrective maintenance of the AWG2021. These instructions include cleaning, module removal and installation, and fault isolation to the module.
- *Options* contains information on servicing any of the factory-installed options that your AWG2021 includes.
- *Electrical Parts List* contains a statement referring you to *Mechanical Parts List*, where both electrical and mechanical modules are listed. See below.
- *Diagrams* contains block diagrams and an interconnection diagram useful in isolating failed modules.
- *Mechanical Parts List* includes a table of all replaceable modules, their descriptions, and their Tektronix part numbers.

Manual Conventions

This manual uses certain conventions that you should become familiar with.

Some sections of the manual contain procedures for you to perform. To keep those instructions clear and consistent, this manual uses the following conventions:

- Instructions for menu selection follow this format: **FRONT PANEL BUTTON**→**Main Menu Button**→**Side Menu Button**. For example, “Press **UTILITY**→**Misc**→**Reset to Factory**→**O.K.**”
- Names of front panel controls and menus appear in the same case (initial capitals, all uppercase, etc.) in the manual as is used on the AWG2021 front panel and menus. Front panel names are all upper-case letters; for example, **MODE MENU**, **CH 1**, etc.
- Instruction steps are numbered unless there is only one step.

Modules

Throughout this manual, any replaceable component, assembly, or part of the AWG2021 is referred to generically as a module. In general, a module is an assembly (like a circuit board), rather than a component (like a resistor or an integrated circuit). Sometimes a single component is a module; for example, the chassis of the AWG2021 is a module.

Safety

Symbols and terms related to safety appear in the *Safety Summary* near the beginning of this manual.

Finding Other Information

Other documentation for the AWG2021 Arbitrary Waveform Generator includes:

- The *AWG2021 User Manual* contains a tutorial to quickly describe how to operate the AWG2021. It also includes an in-depth discussion on how to more completely use AWG2021 features.
- The *AWG2021 Programmer Manual* explains how to control the AWG2021 with a computer through the GPIB or RS-232-C interface.

Introduction

This manual contains information needed to properly service the AWG2021 Arbitrary Waveform Generator, as well as general information critical to safe and effective servicing.

To prevent personal injury or damage to the AWG2021, consider the following before attempting service:

- The procedures in this manual should be performed only by a qualified service person
- Read the *General Safety Summary* and the *Service Safety Summary*, beginning on page ix near the beginning of this manual
- Read *Preparation for Use* in section 2, *Operating Information*

When using this manual for servicing, be sure to follow all warnings, cautions, and notes.

Adjustment Interval

Generally, the manual adjustments described in section 5, *Adjustment Procedures*, should be done every 12 months. In addition, adjustment is recommended after module replacement.

Strategy for Servicing

Throughout this manual, the term, module, refers to any field-replaceable component, assembly, or part of the AWG2021.

This manual contains all the information needed for periodic maintenance of the AWG2021. (Examples of such information are procedures for checking performance and for readjustment.)

Further, it contains all information for corrective maintenance down to the module level. To isolate a failure to a module, use the fault isolation procedures found in *Troubleshooting*, part of section 6, *Maintenance*. To remove and replace any failed module, follow the instructions in *Removal and Installation Procedures*, also part of section 6. After isolating a faulty module, replace it with a fully-tested module obtained from the factory. Section 10, *Mechanical Parts List*, contains part number and ordering information for all replaceable modules.

Tektronix Service Offerings

Tektronix provides service to cover repair under warranty as well as other services that may provide a cost-effective answer to your service needs.

Whether providing warranty repair service or any of the other services listed below, Tektronix service technicians are well equipped to service the AWG2021. Tektronix technicians train on Tektronix products; they have access to the latest information on improvements to the AWG2021 as well as the latest new options.

Warranty Repair Service

Tektronix warrants this product for one year from date of purchase. (The warranty appears on the back of the title page in this manual.) Tektronix technicians provide warranty service at most Tektronix service locations worldwide. The Tektronix product catalog lists all service locations worldwide.

Repair or Calibration Service

The following services can be purchased to tailor repair and/or calibration of the AWG2021 to fit your requirements.

At-depot Service. Tektronix offers several standard-priced adjustment (calibration) and repair services:

- A single repair and/or adjustment
- Calibrations using equipment and procedures that meet the traceability standards specific to the local area
- Annual maintenance agreements that provide for either calibration and repair or calibration only of the AWG2021

Of these services, the annual maintenance agreement offers a particularly cost-effective approach to service for many owners of the AWG2021.

Self Service

Tektronix supports repair to the module level by providing *Module Exchange*.

Module Exchange. This service reduces down-time for repair by allowing you to exchange most modules for remanufactured ones. Tektronix ships an updated and tested exchange module from the Beaverton, Oregon service center, typically within 24 hours. Each module comes with a 90-day service warranty.

For More Information. Contact your local Tektronix service center or sales engineer for more information on any of the repair or adjustment services just described.

Specifications

Product Description

The AWG2021 is a portable arbitrary waveform generator capable of generating both arbitrary waveforms and standard function waveforms. Key features include:

- Arbitrary waveform generation from waveform data files that you:
 - Create using the graphical waveform editor
 - Generate from equations you create using the equation editor
 - Transfer from GPIB or RS-232-C interfaces
 - Directly transfer from a Tektronix TDS Digitizing Oscilloscope, 2200 Series, 2400 Series, or 11000 Series Digital Storage Oscilloscope (DSO), DSA Series Digital Analyzer, RTD710A Transient Digitizer, AFG2020 Arbitrary Function Generator, or from another AWG2000 Series Arbitrary Waveform Generator
- Continuous generation of arbitrary waveform data files you specify in a sequence file
- Stepped arbitrary waveform generation of waveform data files and/or sequence files you specify in an autostep file (Autostep mode)
- Single- or dual-channel waveform output to 5 V_{p-p} (the second channel is Option 02)
- Point clock rate from 10 Hz to 250 MHz
- Continuous, triggered, gated, or burst trigger modes
- Amplitude modulation
- Output waveform Add function (CH 2 to CH1)
- Internal waveform memory of 256K × 12 bits for each channel
- Internal catalog memory of 2.2 M
- Waveform file storage in internal nonvolatile memory (512K) or on external disk
- Two waveform markers (per channel)
- Rear-panel waveform output in digital format for ECL level (Option 03)
- Rear-panel waveform output in digital format for TTL level (Option 04)

- Editing in frequency domain and convolution waveform editor capability (Option 09)
- Sample waveform library and sample GPIB programming examples on disk
- Standard function waveforms
- Internal diagnostic/calibration

Performance Characteristics

This subsection describes the conditions required for the AWG2021 to operate to specified characteristics.

Performance Conditions

The electrical characteristics are valid under the following conditions:

1. The instrument must have been calibrated at an ambient temperature from +20° C to +30° C.
2. Allow twenty minutes warm-up time for operation to specified accuracy.
3. The instrument operates at an ambient temperature from +10° C to +40° C, unless otherwise noted.

Any conditions that are unique to a particular characteristic are expressly stated as part of that characteristic.

The electrical and environmental performance limits, together with the related validation procedure, comprise a complete statement of the electrical and environmental performance of a calibrated instrument.

Electrical characteristic limits in the *Description* column are verified by completing the test listed in the *Performance Test* column.

Introduction

The performance characteristics on the AWG2021 can be divided into three categories:

- *Nominal Traits*. General characteristics are described not by equipment performance and limits but by such things as memory capacity.
- *Warranted Characteristics*. Warranted characteristics are described in terms of quantifiable performance limits which are guaranteed.
- *Typical Characteristics*. Typical characteristics are described in terms of typical or average performance for the AWG2021. The characteristics described herein are not absolutely guaranteed.

Nominal Traits

This section contains a collection of tables that list the various *nominal traits* that describe the AWG2021 Arbitrary Waveform Generator. Electrical and mechanical traits are included.

Nominal traits are described not by equipment performance and limits but by such things as memory capacity.

Table 1-1: Electrical Characteristics

Characteristics	Description	Performance Test
Operating Modes		
Continuous	Generates the waveform continuously.	Check Cont Mode, page 4-12.
Triggered	Output quiescent until triggered by an external, GPIB or manual trigger; then generates a waveform or sequence only one time.	Check Triggered Mode, page 4-14.
Gated	Same as triggered mode except periods are output for the duration of the gated signal.	Check Gated Mode, page 4-18.
Burst	Output quiescent until triggered by an external, GPIB or manual trigger; then generates a waveform or sequence predefined count.	Check Burst Mode, page 4-16.
Waveform Advance	Continuously generates the waveform in the predefined (edited) sequence and the next trigger advances the waveform.	Check Waveform Advance Mode, page 4-21.
Autostep	Outputs the first waveform in the predefined Autostep File once. The next trigger advances to output the next waveform once and so on, for each successive trigger.	Check Autostep Mode, page 4-23
Arbitrary Waveforms		
Waveform Memory		
Memory Length		
Waveform	256K × 12 bits	
Marker1	256K × 1 bit	
Marker2	256K × 1 bit	
Waveform	64 to 256K in multiple of 8 data points	
Sequence Memory	8K, 32 bits/word	
Scan Counter	1 to 64 K (16 bits)	
Burst Counter	1 to 64 K (16 bits)	

Table 1-1: Electrical Characteristics (Cont.)

Characteristics	Description	Performance Test
Main Output		
Amplitude	Except multiply (AM) and add (Add) operation	
Range	0.05 to 5 V _{p-p} into 50 Ω The amplitude range expands about 2 times (10 V _{p-p}) into open circuit. Its actual value is two times the displayed value. ±10 V ≥ (The absolute peak Amplitude + Offset)	
Resolution	1 mV	
Offset		
Range	±2.5 V into 50 Ω The offset range expands about 2 times (-5 V to +5 V) into open circuit. Its actual value is two times the displayed value. ±10 V ≥ (The absolute peak Amplitude + Offset) -100 mA to +100 mA into 50 Ω (current source output)	
Resolution	5 mV	
Impedance	50 Ω	
Auxiliary Output		
SYNC	When F.G mode and the frequency is above 250 kHz, the Sync pulse occurs one time per two waveforms.	
Amplitude	>1.2 V into 50 Ω, >2.4 V into open circuit	
Impedance	50 Ω	
MARKER1		
Amplitude	2.5 V (+5%, -10%) into 50 Ω, 5 V (+5%, -10%) into open circuit	
Impedance	50 Ω	
Period Jitter	Refer to Table 1-1-1 (measured by TDS694C-1MHD with TDSJIT1)	
Cycle to Cycle Jitter	Refer to Table 1-1-2 (measured by TDS694C-1MHD with TDSJIT1)	
MARKER2		
Amplitude	2.5 V (+5%, -10%) into 50 Ω, 5 V (+5%, -10%) into open circuit	
Impedance	50 Ω	
CLOCK		
Amplitude	1 V into 50 Ω	
Impedance	50 Ω	

Table 1-1: Electrical Characteristics (Cont.)

Characteristics	Description	Performance Test
Period Jitter	Refer to Table 1-1-3 (measured by TDS694C-1MHD with TDSJIT1)	
Cycle to Cycle Jitter	Refer to Table 1-1-4 (measured by TDS694C-1MHD with TDSJIT1)	
ECL DIGITAL DATA OUT (Option 03)		
Level	ECL compatible	
Output Signals	Same wires to DAC Data (D0 to D11) Clock	
TTL DIGITAL DATA OUT (Option 04)		
Output Signals		
CH1	Data (D0 to D11), Clock	
CH2 (Option 02)	Data (D0 to D11), Clock	
Amplitude	>2 V into 50 Ω	
Impedance	50 Ω	
Connector	26 pin header	
Auxiliary Input		
TRIGGER		
Threshold Level	-5 V to 5V	
Resolution	0.1V	
Impedance	1 M Ω with 30 pF (max) or 50 Ω	
ARM		
Range	2 V _{p-p} (-1V to 1V) for 100% modulation	
Impedance	10 k Ω	
CLOCK		
Impedance	50 Ω	
Function Generator		
Waveform Shape	Sine, Triangle, Square, Ramp, Pulse	
Output Parameter	All of these values with the exception of frequency can be set independently for each channel. Frequency settings apply to each channel.	
Frequency	1.000 Hz to 2.500 MHz	
Amplitude	Can be set between 50 mV and 5 V in 1 mV increments	
Offset	Can be set between ± 2.5 V in 5 mV increments	
Polarity	Normal, Invert	

Table 1-1: Electrical Characteristics (Cont.)

Characteristics	Description	Performance Test
Duty	0% to 100% Pulse only. Can be set in 1% increments	
Operating Mode	Continuous mode	
Auxiliary Output Marker Signal	2.5 V into 50 Ω , generated at the starting point of the waveform. The pulse width will vary depending on the frequency.	
Display		
CRT		
Display Area	5.2 inches horizontally by 3.9 inches vertically	
Resolution	640 (H) \times 480 (V) pixels	
AC Power Source		
AC Line Power		
Fuse Rating	6A fast blow, 250 V, UL198G(3AG) or 5 A (T), 250 V, IEC127	
Battery		
Type	Li3 V, 650 mA	

Table 1-1-1 : Period Jitter (CH1 Marker 1 Out)

Clock=250MS/s		Clock=100MS/s	
StdDev	Pk-Pk	StdDev	Pk-Pk
11.0 ps	60.0 ps	10.5 ps	50.0 ps

Table 1-1-2 : Cycle to Cycle Jitter (CH1 Marker 1 Out)

Clock=250MS/s		Clock=100MS/s	
StdDev	Pk-Pk	StdDev	Pk-Pk
20.0 ps	110.0 ps	20.0 ps	90.0 ps

Table 1-1-3 : Period Jitter (Clock Out)

Clock=250MS/s		Clock=100MS/s	
StdDev	Pk-Pk	StdDev	Pk-Pk
11.0 ps	60.0 ps	10.5 ps	50.0 ps

Table 1-1-4 : Cycle to Cycle Jitter (Clock Out)

Clock=250MS/s		Clock=100MS/s	
StdDev	Pk-Pk	StdDev	Pk-Pk
20.0 ps	110.0 ps	20.0 ps	90.0 ps

Table 1-2: Mechanical Characteristics

Characteristics	Description
Net Weight Standard	9.7 kg
Size	
Height	6.4 inches with feet
Width	14.3 inches with handle
Length	19.25 inches with front cover 22.2 inches with handle extended

Warranted Characteristics

This section will describe the warranted characteristics of the AWG2021. These can be divided into two main categories: electrical characteristics and environmental characteristics.

Performance Conditions

The electrical characteristics are valid under the following conditions:

1. The instrument must have been calibrated at an ambient temperature between +20° C to +30° C.
2. The instrument must be in an environment whose limits are described in Environmental Characteristics.
3. All tolerance limits apply after a 20 minute warm up and an execution of the self calibration.
4. The instrument is operating at an ambient temperature between +10° C to +40° C, unless otherwise noted.

Table 1-3: Electrical Characteristics

Characteristics	Description	Performance Test
Clock Generator		
Accuracy		Check Clock Frequency Accuracy, page 4-30.
+15° C to +30° C	0.005%	
+10° C to +40° C	0.01%	
Skew between CH1 and CH2	When Option 02 (second channel) installed within 4 ns	
Filter		
Cutoff frequency	-3 dB point	
1 MHz	Within 20%	
5 MHz	Within 20%	
20 MHz	Within 20%	
50 MHz	Within 20%	
Main Output		
Amplitude		Check Gain Accuracy, page 4-34.
DC Accuracy		
0.05 V to 0.5 V	±(0.5% of Amplitude + 5 mV) No Offset, at 1 MHz clock	
0.501 V to 5 V	±(1% of Amplitude + 25 mV) No Offset, at 1 MHz clock	
Offset	Waveform is 0 VDC and Amplitude range is 0.05 V	Check Offset Accuracy, page 4-36.
Accuracy	± (1% of Offset + 5 mV)	

Table 1-3: Electrical Characteristics (Cont.)

Characteristics	Description	Performance Test
Crosstalk between Channels	Option 02, Sine (512 points), 250 MHz Clock, Amplitude 5 V, No Offset, No Filter <-70 dBc	
Noise Floor	Waveform is 0 VDC (7FF), Norm, No Filter, No Offset, at 250 MHz Clock	
0.1 V	<-140 dBm/Hz (at 10 MHz)	
1.0 V	<-130 dBm/Hz (at 10 MHz)	
5.0 V	<-120 dBm/Hz (at 10 MHz)	
Pulse Response 15° C ~ 30° C		Pulse Response Check, page 4-37.
Flatness	Within <3% (After 20 ns from rise/fall edges)	
Aberration	±(7% of amplitude + 10 mV)	
15° C ~ 30° C		
Rise/Fall Time	<4.2 ns	
Flatness	Within <5% (After 20 ns from rise/fall edges)	
Aberration	±(9% of amplitude + 10 mV)	
Sine Wave Characteristics	F.G mode, 100 kHz to 2.5 MHz, No Offset	
Flatness	Within 4% Amplitude 1 V, 100 kHz reference	
T.H.D.	Including up to 4th Harmonics	
1 V	<-50 dBc	
0.5 V	<-66 dBc	
Spurious	Excluding Clock frequency	
1 V	<-66 dBc	
0.5 V	<-66 dBc	
Auxiliary Output		
SYNC		SYNC OUT Amplitude Check, page 4-40.
Amplitude	>1.2 V into 50 Ω, >2.4 V into open circuit	
Duration	100 ns ± 20%	
Sync to Signal delay	Within 15 ns	
MARKER1		MARKER OUT Amplitude Check, page 4-40.
Amplitude	2.5 V (+5%, -10%) into 50 Ω, 5 V (+5%, -10%) into open circuit	
Rise/Fall time	< 8 ns	
Marker to Signal delay	Within 15 ns	

Table 1-3: Electrical Characteristics (Cont.)

Characteristics	Description	Performance Test
MARKER2		
Amplitude	2.5 V (+5%, -10%) into 50 Ω , 5 V (+5%, -10%) into open circuit	MARKER OUT Amplitude Check, page 4-40.
Rise/Fall time	< 8 ns	
Marker to Signal delay	Within 15 ns	
CLOCK		
Amplitude	1 V \pm 0.3 V into 50 Ω	CLOCK OUT Amplitude Check, page 4-32.
ECL DIGITAL DATA OUT (Option 03)		
Skew between Data	Within 1 ns	ECL DIGITAL DATA OUT Check, page 4-47.
Clock to Data delay	Within 2 ns	
TTL DIGITAL DATA OUT (Option 04)		
Amplitude	>2 V into 50 Ω	TTL DIGITAL DATA OUT Check, page 4-51.
Output Data rate	100 MB/s minimum	
Clock to Data delay (See Figure 1-1)	Within \pm 4 ns	

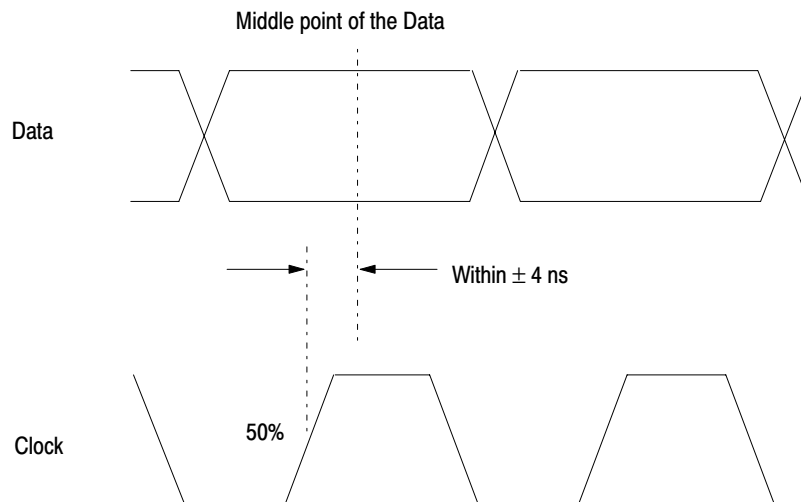

Figure 1-1: Timing for the Data and Clock Signals

Table 1-3: Electrical Characteristics (Cont.)

Characteristics	Description	Performance Test
TRIGGER		
Accuracy	$\pm(5\% \text{ of Level} + 0.1 \text{ V})$	External Trigger Level Accuracy Check, page 4-42.
Pulse Width	15 ns minimum	
Input Swing	0.2 V _{p-p} minimum	
Maximum Input Volts	10 V _{p-p} when 1 M Ω selected 5 V _{RMS} when 50 Ω selected	
Trigger to Signal delay		
Internal Clock	100 ns maximum	
External Clock	100 ns maximum + 0.5 Clock + 1 Clock maximum	
Trigger Holdoff	1 μ s maximum (Excluding Autostep mode)	
AM		
Amplitude Accuracy	Within 5%	
Maximum Input Volts	$\pm 5 \text{ V}$	
CLOCK		
Threshold Level	0.5 V	External CLOCK IN Check, page 4-45.
Input Swing	0.8 V _{p-p} minimum	
Pulse Width	2 ns minimum	
Maximum Input Volts	$\pm 2 \text{ V}$	
Frequency Range	250 MHz maximum	
AM and Add		
AM (Multiply)	When Option 02 (second channel) installed	Check Internal AM Operation, page 4-28.
Output	Within 5% CH2 Signal 5 V 100% 0 V 0% -5 V -100%	
Frequency Response	DC to 30 MHz (-3 dB)	
External AM		
Sensitivity	2 V _{p-p} ($\pm 5\%$) signal causes 100% modulation. Ext Signal 1V 100% modulation 0V 50% modulation -1V 0% modulation	Check External AM Operation, page 4-25.
Frequency Response		
CH1	DC to 30 MHz (-3 dB)	
External Signal	DC to 4 MHz (-3 dB)	

Table 1-3: Electrical Characteristics (Cont.)

Characteristics	Description	Performance Test
Add	When Option 02 (second channel) installed	Check Internal Add Operation, page 4-29.
Output	Within 5% CH1 + CH2 (value indicated at the lower right box in SETUP menu) Output can not exceed 5 V _{p-p} .	
Frequency Response	DC to 30 MHz (-3 dB)	
AC Power Source		
Rating Voltage	100 VAC to 240 VAC Continuous range, CAT II	
Range		
90 VAC to 250 VAC	48 Hz to 63 Hz	
90 VAC to 127 VAC	48 Hz to 440 Hz	
Maximum Power Consumption	300 W	
Maximum Current	4 A	
Grounding Impedance	The impedance for the chassis ground and power plug ground pins is 0.1 Ω at 30 A.	
Primary Circuit Dielectric Voltage withstand Test	1500 V _{RMS} , 50 Hz for 15 seconds, without breakdown.	

Table 1-4: Environmental Characteristics

Characteristics	Description
Temperature	
Operating	+10° C to +40° C
Non-operating	-20° C to +60° C
Relative Humidity	
Operating	20% to 80% (No condensation) Maximum wet-bulb temperature 29.4° C
Non-operating	5% to 90% (No condensation) Maximum wet-bulb temperature 40.0° C
Altitude	
Operating	To 4.5 km (15000 ft) Maximum operating temperature decreases 1° C each 300 m above 1.5 km
Non-operating	To 15 km (50000 ft)
Dynamics	
Vibration	
Operating	0.33 mm _{p-p} , 10 to 55 Hz, 15 minutes
Shock	
Non-operating	294 m/s ² (30 G), half-sine, 11 ms duration
Installation Requirements	
Power Consumption (Fully Loaded)	300 watts max. Maximum line current is 4 A _{RMS} at 50 Hz, 90 V line
Surge Current	30 A peak for < 5 line cycles, after product has been off for at least 30 s
Cooling Clearance	
Top Clearance	3 inches
Side Clearance	6 inches
Rear Clearance	3 inches

Typical Characteristics

This section will describe the typical characteristics for the AWG2021. These values represent typical or average performance and are not absolutely guaranteed.

Table 1-5: Electrical Characteristics

Characteristics	Description
Delay	
1 MHz	390 ns
5 MHz	78 ns
20 MHz	18 ns
50 MHz	11 ns
Auxiliary Output	
TTL DIGITAL DATA OUT	Option 04
Skew between Data	Connect a digital data output cable (P/N 174-3192-00) between DIGITAL DATA OUT connector and DUT's header pins with 50 Ω termination.
Same Channel	2 ns
Between CH1 and CH2	4 ns (when Option 02 installed)
Power Supply	
Battery	
Back up Time	4 years

Table 1-6: Certifications and compliances

Category	Standards or description
EC Declaration of Conformity – EMC	<p>Meets intent of Directive 89/336/EEC for Electromagnetic Compatibility. Compliance was demonstrated to the following specifications as listed in the Official Journal of the European Communities:</p> <p>EMC Directive 89/336/EEC:</p> <p> EN 55011 Class A Radiated and Conducted Emissions</p> <p> EN 50081-1 Emissions:</p> <p> EN60555-2 AC Power Line Harmonic Emissions</p> <p> EN 50082-1 Immunity:</p> <p> IEC801-2 Electrostatic Discharge Immunity</p> <p> IEC801-3 RF Electromagnetic Field Immunity</p> <p> IEC801-4 Electrical Fast Transient/Burst Immunity</p>

Table 1-6: Certifications and compliances (cont.)

Category	Standards or description
Australian/New Zealand declaration of Conformity - EMC	Complies with EMC provision of Radio-communications Act per the following standard: AS/NZS 2064.1/2 Industrial, Scientific, and Medical Equipment: 1992
EC Declaration of Conformity - Low Voltage	Compliance was demonstrated to the following specification as listed in the Official Journal of the European Communities: Low Voltage Directive 73/23/EEC, amended by 93/68/EEC EN 61010-1/A1:1992 Safety requirements for electrical equipment for measurement, control and laboratory use.
Approvals	Complies with the following safety standards: UL3111-1, First Edition Standard for electrical measuring and test equipment. CAN/CSA C22.2 No.1010.1-92 Safety requirements for electrical equipment for measurement, control and laboratory use.
Installation Category Description	Terminals on this product may have different installation (over-voltage) category designations. The installation categories are: Category Examples of products in this category CAT III Distribution-level mains (usually permanently connected). Equipment at this level is typically in a fixed industrial location. CAT II Local-level mains (wall sockets). Equipment at this level includes appliances, portable tools, and similar products. Equipment is usually cord-connected. CAT I Secondary (signal level) or battery operated circuits of electronic equipment.
Pollution Degree	A measure of the contaminates that could occur in the environment around and within a product. Typically the internal environment inside a product is considered to be the same as the external. Products should be used only in the environment for which they are rated. Pollution Degree 2 Normally only dry, nonconductive pollution occurs. Occasionally a temporary conductivity that is caused by condensation must be expected. This location is a typical office/home environment. Temporary condensation occurs only when the product is out of service.
Conditions of Approval	Safety Certifications/Compliances are made for the following conditions: Altitude (maximum operation): 2000 meters
IEC Characteristics	Equipment type: Test and Measuring Installation Category II (as defined in IEC 61010-1, Annex J) Pollution Degree 2 (as defined in IEC 61010-1) Safety Class I (as defined in IEC 61010-1, Annex H)

Operating Information

Preparation for Use

This section describes how to prepare the AWG2021 Arbitrary Waveform Generator for use. The information describes these items:

- Proper operating environment
- Checking power cord and line voltage configurations
- Checking the fuse
- Power-on and power-off cycles

Supplying Power

Before installing the AWG2021, note these precautions:



WARNING. *To avoid equipment failure and potential fire or personal shock hazards, do not exceed the maximum rated operating voltage of 250 V between the voltage-to-ground (earth) and either pole of the power source. The AWG2021 operates from a single-phase power source and has a three-wire power cord with a two-pole, three-terminal grounding plug. Also, before making connection to the power source, be sure the AWG2021 has a suitable two-pole, three-terminal grounding-type plug.*

To avoid personal shock hazard, do not contact conductive parts. All accessible conductive parts are directly connected through the grounding conductor of the power cord to the grounded (earthing) contact of the power plug. The AWG2021 is safety Class 1 equipment (IEC designation).

To avoid personal shock hazard, do not defeat the grounding connection. Insert the power input plug only in a mating receptacle with a grounding contact where earth ground has been verified by a qualified service person. Also, for electrical shock protection, make the grounding connection before making connection to the AWG2021 input or output terminals.

Power Cord Information

The AWG2021 ships with the required power cord as ordered by the customer. Table 2-1 gives the color-coding of the conductors in the power cord. Table 2-2 shows information on the available power cords.

Table 2-1: Power-Cord Conductor Identification

Conductor	Color	Alternate Color
Ungrounded (Line)	Brown	Black
Grounded (Neutral)	Light Blue	White
Grounded (Earthing)	Green/Yellow	Green

Table 2-2: Power Cord Identification

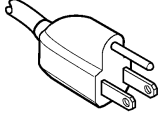
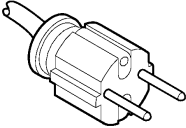
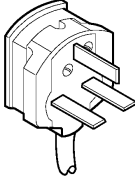
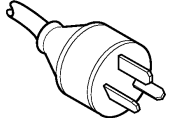
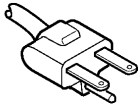
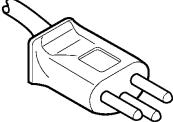
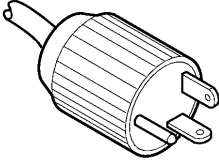
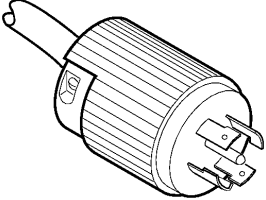
Plug Configuration	Normal Usage	Option Number
	North America 125 V	Standard
	Europe 230 V	A1
	United Kingdom 230 V	A2
	Australia 230 V	A3
	North America 230 V	A4
	Switzerland 230 V	A5
	North American 115V/15A Plug NEMA 5-20P	1A
	North American 120/208V 3-Phase Plug NEMA L21-30P	1B

Operating Environment

To ensure proper AWG2021 operation and long life, note the following environmental requirements.

Operating Temperature

The AWG2021 operates in an environment with an ambient air temperature between +10° C and +40° C. The AWG2021 storage temperature ranges from -20° C to +60° C. After storage at temperatures outside the operating limits, allow the AWG2021 chassis to stabilize at a safe operating temperature before applying power.

Ventilation Requirements

Air drawn in and exhausted through the cabinet side and bottom panels cools AWG2021 internal circuits. To ensure proper cooling, allow the following clearances:

Top and back 7.5 cm (3 in.)
Left and right 15 cm (6 in.)

The feet on the bottom of the AWG2021 cabinet provide the required clearance when it is set on a flat surface. The top of the AWG2021 does not require ventilation clearance.



CAUTION. To prevent temporary shutdown of the AWG2021, do not restrict air flow through the chassis. If the AWG2021 shuts down unexpectedly, improve ventilation around the AWG2021 and wait a few minutes to allow it to cool down; then switch the power on again.

Rear Panel Controls

Section 1, *Specifications*, lists the line voltage and frequency ranges over which the AWG2021 operates.

Figure 2-1 shows the rear panel controls for the AWG2021.

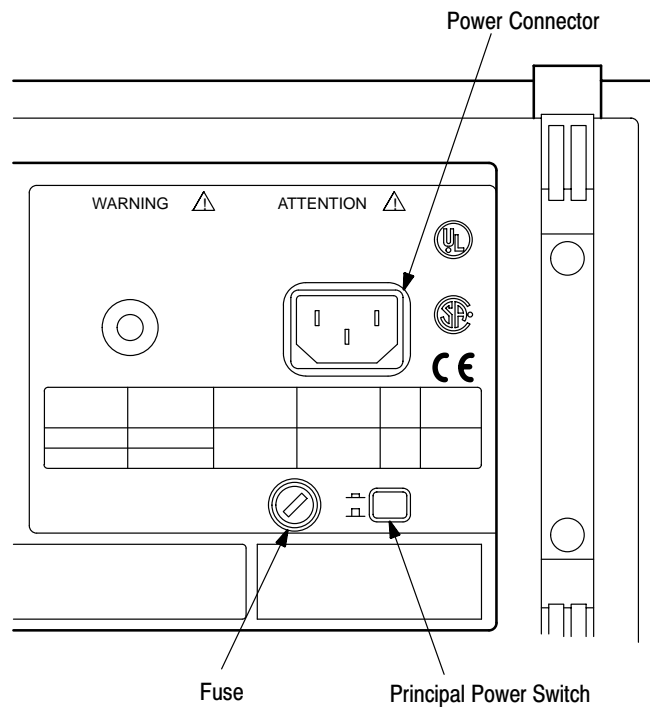

Figure 2-1: Rear Panel Controls

Fuse Type and Rating

The AWG2021 uses the same fuse for all operating line voltage ranges. One of two fuse types is installed in the instrument, depending upon the power cord option. Table 2-3 provides the available types and ratings.

Table 2-3: Fuse Type and Rating

Power Cord Option	Fuse	Fuse Part Number	Fuse Cap Part Number
Standard, A3, A4, A5	0.25 inch × 1.25 inch (UL 198G,3AG):6A FAST,250V	159-0239-00	200-2264-00
A1, A2	5 mm × 20 mm (IEC 127): 5A(T),250V	159-0210-00	200-2265-00



WARNING. To avoid electrical shock, always unplug the power cord from the socket before checking the line fuse.

To check the fuse, remove the fuse holder on the rear panel. Refer to Figure 2-1 for the location of the fuse holder. To remove the fuse holder, turn it counter-clockwise with a screwdriver while pushing it in. Then remove the fuse from the fuse holder.

Applying and Interrupting Power

Consider the following information when you power on or power off the AWG2021, or when external power loss occurs.

Power-on Cycle

At power-on, the start-up diagnostics check the AWG2021 operation. The start-up diagnostics take about 30 seconds. If all diagnostic items complete without error, the AWG2021 displays *PASS* on the screen and then changes to the SETUP menu.

If the diagnostics detect an error, the AWG2021 displays *FAIL* and the error code. To exit the diagnostics menu, press any key; then the system displays the SETUP menu. See section 6, *Maintenance*, for information on diagnostics and fault isolation.

NOTE. *If the ambient temperature goes outside the specified operating temperature range, an error occurs during the diagnostics at power-on. If this happens, power off the AWG2021 and wait until the chassis temperature is appropriate; then switch the power on again.*

Power-off Cycle



CAUTION. *To prevent loss of internally stored adjustment constants, DO NOT power off the AWG2021 when doing the internal calibration described in section 5, *Adjustment Procedures*.*

Wait for the AWG2021 to finish the operation when doing internal calibration or saving waveform or sequence files. Improper power-off or unexpected loss of power to the AWG2021 can result in the corruption of data stored in nonvolatile memory.

Memory Backup Power

A lithium battery maintains internal nonvolatile memory, allowing the AWG2021 to retain waveform and sequence files if AC power is lost. This battery has a shelf life of about three years. Partial or total loss of stored information at power-on may indicate that the battery needs to be replaced.



WARNING. *To avoid risk of fire or explosion, replace the AWG2021 battery with a lithium battery having the part number listed in section 10, Mechanical Parts List. This battery is a safety-controlled part.*

To avoid risk of fire or explosion, do not recharge, rapidly discharge, or disassemble the battery; and do not incinerate the battery or heat it above 100° C. Also, dispose of used batteries promptly. Small quantities of used batteries can be disposed of in normal refuse. Keep lithium batteries away from children.

Repackaging Instructions

Use a corrugated cardboard shipping carton having a test strength of at least 275 pounds and with an inside dimension at least six inches greater than the AWG2021 dimensions. (If available, use the original shipping carton, which meets these requirements.)

If the AWG2021 is shipped to a Tektronix Service Center, enclose the following information:

- The owner's address
- Name and phone number of a contact person
- Type and serial number of the AWG2021
- Reason for returning
- A complete description of the service required

Seal the shipping carton with an industrial stapler or strapping tape.

Mark the address of the Tektronix Service Center and your own return address on the shipping carton in two prominent locations.

Installed Options

Your AWG2021 may include one or more options. To determine which options are installed, power on the AWG2021 and look at the display during the power-on sequence. The AWG2021 lists the installed options after Options, near the top of the display.

Table 2-2 on page 2-3 gives information about line cord options. Section 7, *Options*, lists other options and optional accessories. For further information and prices of options, see your Tektronix Products catalog or contact a Tektronix Field Office.

Operating Instructions

Before servicing the AWG2021, read the following operating instructions. These instructions are at the level appropriate for servicing the AWG2021. The user manual contains complete operator instructions.

In addition, section 4, *Performance Verification*, includes instructions for making the front-panel settings required to check AWG2021 characteristics.

How to Power On

To power-on the AWG2021, follow these steps:

1. Set the **PRINCIPAL POWER SWITCH** (on the back of the AWG2021) to the ON position. This switch is the main power switch; it routes power to the standby circuit in the AWG2021.
2. Then, press the **ON/STBY** (standby) switch on the front (lower-left corner) of the AWG2021. This switch applies power to the remaining circuits of the AWG2021. Allow at least 20 minutes for the AWG2021 to warm up.



WARNING. *To avoid personal shock hazard, turn off both the ON/STBY switch and the PRINCIPAL POWER SWITCH before servicing. The PRINCIPAL POWER SWITCH on the rear panel is the true power disconnect switch. The ON/STBY (standby) switch simply toggles operation on and off. When connected to a power source and when the PRINCIPAL POWER SWITCH is on, the internal power supplies and much of the other circuitry of the AWG2021 remain energized regardless of the setting of the ON/STBY switch.*

To avoid personal shock hazard, set the PRINCIPAL POWER SWITCH off before connecting or disconnecting the line cord to or from the power source.

Internal Diagnostics and Calibration Routines

At power-on, the AWG2021 performs internal start-up diagnostics. These diagnostics check internal circuit function and report any failures. In addition, you can initiate internal diagnostics using the **Diag/Cal** item in the UTILITY menu; these diagnostics differ from the start-up diagnostics in that they do more extensive memory checking.

The AWG2021 performs internal calibration routines using the **Diag/Cal** item in the UTILITY menu, which check internal circuit function and adjust calibration constants. Run these calibration routines whenever the AWG2021 undergoes a temperature change. For instance, run the calibration routines after the AWG2021 warms up at power-on. This warmup period and subsequent calibration assures AWG2021 operation at optimum performance levels.

User Interface

The AWG2021 uses a combination of front-panel buttons, keys, a knob, and on-screen menus to control generator functions. Some front-panel controls select menus and manipulate menu items. Others enter values and units, allow manual triggering, and turn on/off AWG2021 output. On-screen graphics show various aspects of the current AWG2021 configuration.

On-screen menus set all AWG2021 functions except manual triggering and output control. Main menus provide access to lower-level nested submenus. Buttons in the center of the front panel select the main menus.

When you select a menu, the display shows the items controlled by that menu and numeric values currently in effect. Buttons around the display select lower-level menus, change menu selections, modify numeric values and units, and execute functions.

Display

Figure 2–2 contains two examples of AWG2021 displays. To see the first display on the AWG2021, press **Edit** in the MENU column; then press **New Waveform** in the side menu. The second display shows an example of the message area. Text after the illustration describes each display feature.

Status Area The status of the AWG2021 always appears in the status line. Status information includes the interface status (refer to programmer manual), operating mode status, trigger status (refer to user manual), and busy icon (a clock) which appears while loading or saving waveform or sequence files.

Date & Time Display This area displays the date and time set in the UTILITY menu. The date and time display can be set to on or off.

Error Display Area If an error occurs during operation, this area displays an error message.

Side Menu Label This area displays a label that matches the bottom menu that was selected.

The screenshot shows the main display interface. At the top, it displays 'GPIB', 'Continuous mode', and 'Stopped'. Below this, it says 'Undo Buffer empty.' and the date/time '15-Jan-94 11:01:08'. The main area contains a waveform plot with a vertical axis ranging from -1.0000 to 1.0005 and a horizontal axis with markers at 200 and 800. A side menu is open on the right, listing 'Operation', 'Cut', 'Copy to Buffer', 'Paste from Buffer', 'Draw...', and 'More 1 of 3'. At the bottom, there is a 'Button Operation' row with buttons for 'Select/Open', 'Operation', 'Zoom', 'Setting', 'Undo', 'Standard Waveform', and 'Close/Write'.

The screenshot shows the 'Catalog : Memory' window with a table of files and a confirmation dialog box. The table lists files with columns for Name, Type, Size, Date & Time, and Comment. A dialog box asks 'Are you sure you want to delete "SAMPLE-1.WFM"?' with 'Cancel' and 'O.K.' buttons. A bottom menu is visible at the bottom with buttons for 'Rename', 'Comment', 'Copy', 'Delete', 'Delete All', and 'Lock On/Off'.

Name	Type	Size	Date & Time	Comment
SAMPLE-1	WFM	2948	94-01-15 11:03	
SAMPLE-2	WFM	2948	94-01-15 11:05	
SAMPLE-3	WFM	2948	94-01-15 11:08	
SAMPLE-4	EQU	452	94-01-15 11:10	
SAMPLE-4	WFM	2948	94-01-15 11:10	
SAMPLE-5	SEQ	960	94-01-15 11:11	
SAMPLE-6	AST	1050	94-01-15 11:13	

Figure 2-2: Display Features

Side Menu	When you select an item from the bottom menu, the corresponding side menu appears on the right side of the screen. To select an item, input numerals, or execute functions, push the soft button corresponding to the side menu item.
Button Operation	This area includes an explanation of front panel operation.
Knob Icon	The knob icon appears next to an item that is selected. To change the value of the item use the general purpose knob or press the numeric and units keys.
Message Area	This area displays messages for the user.
Button Menu	Pushing any button of the MENU column or the F.G button displays the corresponding bottom menu in the lower part of the screen. To select an item from a bottom menu, push the corresponding soft button.

Menus

The AWG2021 operation is primarily controlled by means of menus that correspond to the SETUP, MODE, EDIT, LOAD/SAVE and UTILITY buttons in the MENU column. To display one of these main menus on the screen, push the corresponding button. The button LED indicates which menu is currently selected. Refer to the User Manual for more details concerning these menus. The F.G button under the MENU column selects function generator operation.

- *SETUP Menu.* The SETUP menu sets the following waveform output parameters for each channel: clock source and frequency, waveform or sequence file selection, operation, filter, amplitude, and offset.
- *MODE Menu.* This menu sets the operation output mode. The operation modes are the trigger modes (Cont, Triggered, Gated, and Burst) and the modes which display a waveform in sequence for each trigger (Waveform Advance and Autostep modes). This menu also has an item for setting the timing used to generate synchronization signals.
- *EDIT Menu.* The EDIT menu allows you to edit an existing file saved in internal memory or to create a new file. To modify files in internal memory, use one of the four editors, depending on the waveform file type: waveform edit, sequence edit, equation edit, and autostep edit. Instruments with Option 09 installed have an FFT editor to permit editing in the frequency domain and a convolution editor to operate the waveforms convolution in high speed.

- *LOAD/SAVE Menu.* Here are the functions for this menu:
 - The LOAD menu loads files from the AWG2021 floppy disk drive or nonvolatile internal memory into internal memory.
 - The SAVE menu saves files from the AWG2021 internal memory onto a floppy disk or into nonvolatile internal memory.
- *UTILITY Menu.* Use this menu to rename or delete files saved in the floppy disk or internal nonvolatile memory, to set the parameters of GPIB or RS-232-C, to set AWG2021 date and time, to change display brightness, to set the catalog order, to set the system configure, to set the hardcopy port and format, to check interface status, and to execute internal diagnosis and calibration routines.

Waveform Files

The AWG2021 generates waveform output from four different types of waveform files:

- *Waveform data file (filename.WFM).* This is the basic waveform data file. It contains the waveform data that the AWG2021 loads into memory and reads when generating waveform output. The data in this kind of file can be created using the waveform editor, generated from equations made using the equation editor, transferred in over an interface, or directly transferred in from certain Tektronix instruments. In addition, the waveform editor displays the data in a waveform data file in three formats: graphical, table, and timing.
- *Waveform equation file (filename.EQU).* The waveform equation file contains equations that express waveform characteristics. Compilation of the waveform equation file generates a waveform data file. The AWG2021 generates the waveform output from this file.
- *Waveform sequence file (filename.SEQ).* The waveform sequence file specifies a series of waveform data files. When the AWG2021 executes a waveform sequence file, it sequentially generates waveforms from each waveform data file, in the order specified.
- *Waveform autostep file (filename.AST).* The waveform autostep file specifies a series of waveform data files and/or waveform sequence files. When the AWG2021 executes a waveform autostep file, it generates the waveform for the first file specified. Then it waits for a trigger before generating from the next specified file. The autostep file includes output conditions for each channel.

Waveform Storage and I/O

The AWG2021 has both internal memory and internal nonvolatile memory (NVRAM) for waveform file storage. The AWG2021 generates waveforms from files residing in internal memory. To save a file that is in internal memory, copy it to nonvolatile memory or floppy disk. Only nonvolatile memory retains files at power-off.

The AWG2021 also has a floppy-disk drive for loading files from floppy disk into internal memory or internal nonvolatile memory, and for saving files from either memory to floppy disk. The disk drive accepts 3.5-inch floppy disks in the MS-DOS format.

Loading Files

The following steps explain how to load files from a floppy disk into internal memory.

1. Push the **LOAD/SAVE** button in the MENU column.
2. Turn the disk so the side with the arrow is on top; insert the disk into the AWG2021 floppy disk drive.
3. Push the **Device** button along the bottom menu to select **Disk**. The menu in Figure 2–3 appears.
4. Select the **Load All** button along the side menu to load all files in the root directory on the disk into the AWG2021 internal (volatile) memory. Or, turn the general-purpose knob to highlight the file you want to load and select **Load**. The display indicates which file it is loading. When loading is complete, the clock disappears.
5. Push the floppy drive button and remove the disk from the floppy drive.
6. Push any button in the MENU column (other than LOAD/SAVE) to exit the menu.

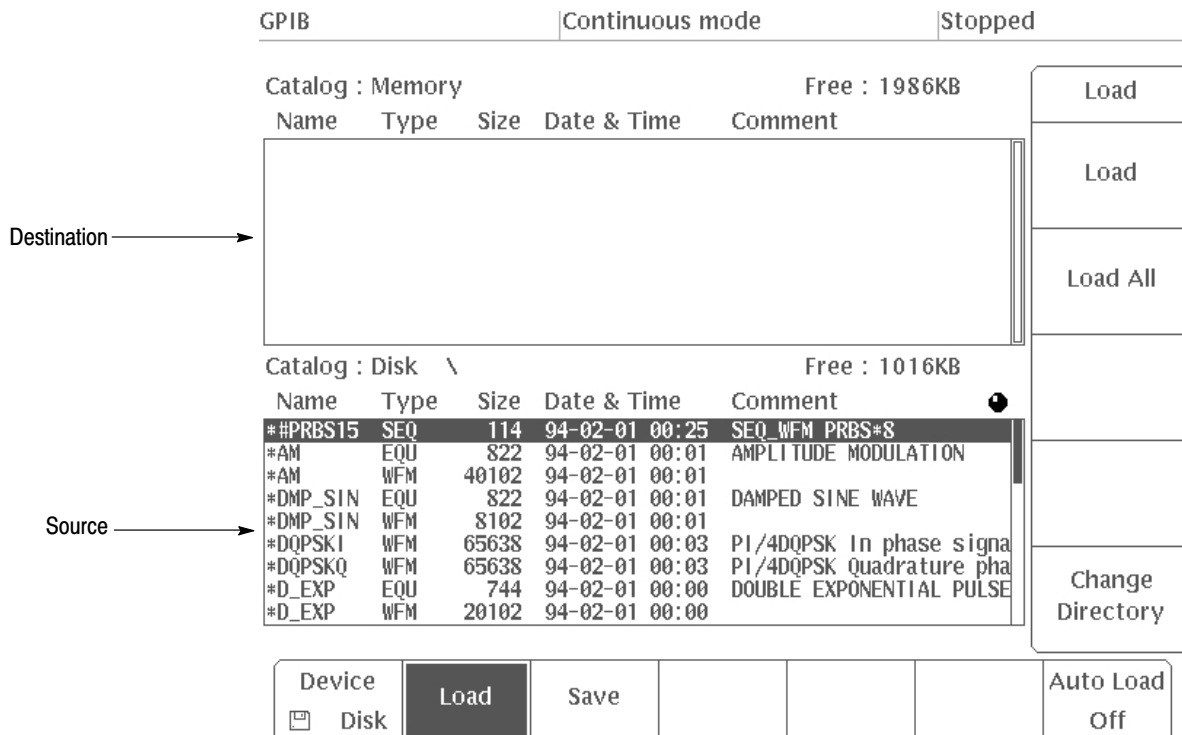

Figure 2-3: LOAD Menu

Setting Output Parameters

The SETUP menu allows you to set various output parameters for outputting a waveform or sequence waveform. To set the output parameters, select a waveform or sequence file (that is already loaded into memory) as the active file.

When you select a file, the AWG2021 changes to the output parameters associated with the file and displays these parameters on the SETUP menu. If you modify the displayed output parameters and later save the file, the modified output parameters are saved with the file. (If the file is locked, you cannot modify the file contents.)

The following steps go through the process of selecting a file and modifying individual output parameters.

1. Push the **SETUP** button in the MENU column. The SETUP menu in Figure 2-4 appears.

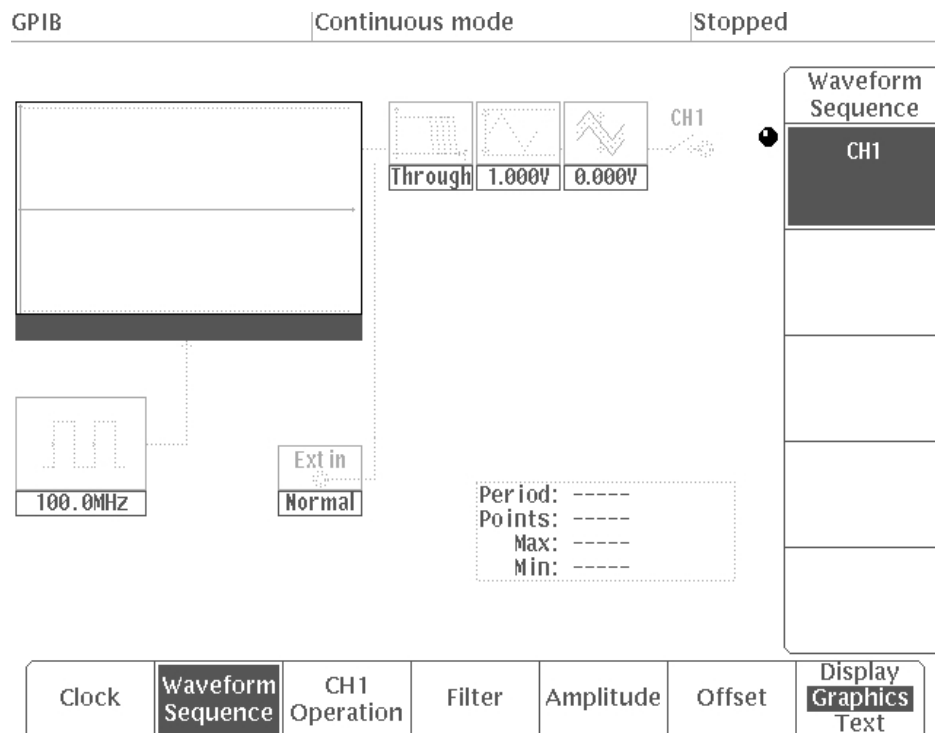

Figure 2-4: SETUP Menu

2. Select **Waveform Sequence** from the bottom menu.
3. Turn the general purpose knob to highlight a file in the displayed list of files; these are the files currently in internal memory. Then push **ENTER** to select the file; the AWG2021 changes to the output parameters associated with the file you selected.
4. After the file is selected, push the front panel **VALUE** button. Now you can modify output waveform parameters.
5. Set the individual parameters as follows:
 - a. Push the **SETUP** button in the MENU column (if the button is not selected).
 - b. Now select the appropriate item from the bottom menu; then use the numeric keys or general purpose knob to modify the parameter setting.

The following explains each item in the bottom menu.

- *Clock*. This item sets the clock source and clock frequency. The clock source can be set to either internal or external.

The clock period is the time between the data points for the waveform created. Therefore, the product of the clock period and the number of waveform points is the waveform or sequence period. For example, if the clock frequency is 1 MHz (period of 1 μ s) and there are 100 waveform points, the waveform period is displayed as 100 μ s.

With Option 02 (the CH2 output option) installed, the CH2 clock is the CH1 clock frequency divided by any value entered for Divider.

- *Operation.* This item performs an arithmetic operation between the CH1 waveform and another waveform, and outputs the result at the CH1 output connector. The operations are addition (Add) and multiplication (AM, External AM).

If the AWG2021 has only one channel, the items available are External AM and Normal. With Option 02 (the CH2 output option) installed, the operations available are Add, AM, External AM, and Normal.

- *Filter.* This item selects a filter that restricts the frequency band for the output channel. Choose a 50, 20, 5, or 1 MHz filter, or you can select Through (no filter).
- *Ampl.* This selection sets the voltage value for the 12-bit, full-scale, output amplitude on the vertical scale. The amplitude can be set in steps of 1 mV within the range from 0.05 V to 5 V.
- *Offset.* This item sets the offset level of the output waveform. The offset can be set in steps of 5 mV within the range ± 2.5 V.

Operation Mode Settings

The MODE menu initiates the waveform output with the output conditions set using the SETUP menu.

1. Push the **MODE** button in the MENU column. The MODE menu in Figure 2–5 appears.
2. Select the operation mode from the bottom menu. The operation modes are Cont, Triggered, Gated, Burst, Waveform Advance, and Autostep.

In all modes except Cont, the trigger or gate signal source can be the external signal applied to the TRIGGER INPUT connector, or a trigger can be generated by pushing the front panel TRIGGER MANUAL button. The individual modes are described below:

- *Cont Mode.* When you push the Cont button, the AWG2021 immediately outputs the specified waveform or sequence waveform, continuously.
- *Triggered Mode.* In triggered mode, the AWG2021 outputs the specified waveform or sequence waveform once, when a trigger occurs.

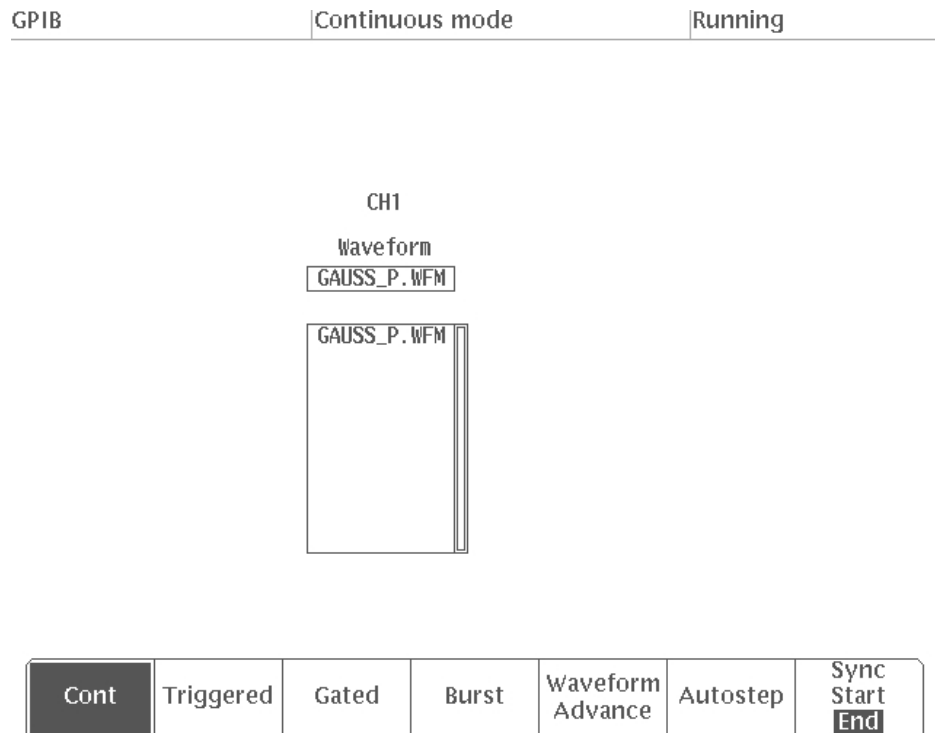

Figure 2-5: MODE Menu

- *Gated Mode.* In gated mode, the gate signal controls the waveform or sequence output.

As long as the front panel MANUAL button is pushed (or the gating signal is high), the AWG2021 outputs the specified waveform or sequence. When the MANUAL button is released (or the gating signal goes low), the waveform output stops. When the MANUAL button is pushed again, the output resumes from the level at which the waveform or sequence output stopped.

- *Burst Mode.* With a trigger applied in burst mode, the AWG2021 outputs the number of waveforms or sequences set by the burst count. When completed, the waveform output stops.
- *Waveform Advance Mode.* In Waveform Advance mode, the AWG2021 ignores the waveform repetition counts set up for each waveform file in the sequence file, and continuously outputs the waveform until the next trigger event.

When the AWG2021 receives a trigger, it changes to output the next waveform in the sequence (after completion of the current waveform). The next waveform output continues until the next trigger event, and so on. After the final waveform in the sequence, output returns to the first waveform in the sequence file. Use the sequence editor to modify the sequence file.

- *Autostep Mode.* Autostep mode uses the waveform file list and output parameter information in an autostep file. In this mode, the AWG2021 outputs one waveform when a trigger occurs, just as in Waveform Advance mode. The difference is that in this mode, the SETUP output parameters change with the waveform data. Also, the operation mode for each step is triggered; the AWG2021 outputs each waveform or sequence output once. Output then stops until the next trigger event. After the AWG2021 generates each waveform in the autostep file, it does not start over with the first file listed. To generate the waveform files again, you must select the autostep file again for execution. Use the autostep editor to modify the autostep file.
3. Set the trigger (gate) conditions for the external trigger (gate) source.

The external trigger (gate) signal is input from the **TRIGGER INPUT** connector on the front panel. This connector allows external signals with a maximum input voltage of $10 V_{p-p}$ into a $1 M\Omega$ input impedance, and a maximum input voltage of $5 V_{RMS}$ into a 50Ω input impedance.

When an operating mode other than Cont is selected, the AWG2021 displays a side menu for selecting the trigger (gate) conditions for the external trigger (gate) source. The following describes each of these items:

- *Slope.* This item sets the slope for external trigger signals. To select a positive or negative slope, push the side menu **Slope** button. For a positive slope, the AWG2021 applies the trigger at the rising edge of the external trigger signal; for a negative slope, the trigger is applied at the falling edge of the external trigger signal.
- *Polarity (Gated Mode).* This item sets the polarity for the gate that outputs the waveform or sequence based on the level of the external gate signal. To set the polarity, push the side menu **Polarity** button. For a positive polarity, the AWG2021 outputs the waveform or sequence waveform while the gate signal level is higher than the gate level parameter set with the side menu Level item. For negative polarity, waveform output occurs while the gate signal level is lower.
- *Level.* This item sets the external trigger (gate) signal level. To set this parameter, push the side menu **Level** button, then use the numeric keys or the general purpose knob to change the value. The trigger (gate) level can be set in steps of $0.1 V$ within the range from $-5.0 V$ to $+5.0 V$.
- *Impedance.* This item sets the input impedance for the external trigger (gate) source to either 50Ω or $1 M\Omega$. To select the value for this parameter, push the side menu **Impedance** button.

Theory of Operation

Theory of Operation

This section describes the basic operation of the major circuit blocks or modules in the AWG2021. Section 9, *Diagrams*, includes three block diagrams and two interconnect diagrams. Figures 9–1, 9–2, and 9–3 show the modules and functional blocks of the AWG2021 with Options 02, 03, 04, and 09 installed. Figures 9–4 and 9–5 show how the modules interconnect.

Module Overview

The module overview describes the basic operation of each functional circuit block.

The AWG2021 Arbitrary Waveform Generator is a portable, single- or dual-channel instrument. For each channel, the AWG2021 reads the digital waveform data loaded into its waveform memory. The point rate clock determines the rate at which the data is read. The AWG2021 converts the data from digital to analog format and outputs the resulting arbitrary waveform.

Clock Synthesizer (A10, Synthesizer Board)

The clock synthesizer circuit is a PLL oscillator that uses a 12.8 MHz reference crystal. It supplies a point rate clock that is adjustable from 250 MHz to 10 Hz for reading data from CH1 waveform memory. The point rate clock is also divided and used for reading data from Option 02 CH2 waveform memory.

When an external clock source is selected, the external clock signal is passed directly through to the Control board and used for reading waveform data in memory. With Option 02 installed, the CH2 clock divider divides the external clock source based on the selected ratio, thus allowing CH 2 to vary its clock rate.

CH1/CH2 Clock Divider (A21/A31, Control Board)

The clock divider circuit divides the clock signal from the Synthesizer board. The resulting clock is the point rate clock used for reading waveform data from the CH1 or CH2 waveform memory.

Waveform Memory Control (A21, Control Board)

This waveform memory control block controls the waveform memory addresses read out according to the contents of a sequence file.

Waveform Memory (A2, Memory Board)

This functional block contains the memory that holds the waveform digital data. The memory is divided into eight banks; its output is multiplexed. There are 12 bits for waveform data and two bits for waveform markers (for each channel).

Digital-to-Analog Converter (DAC) (A2, Memory Board)

This functional block is a 12-bit high-speed digital-to-analog converter. It converts the digital data from the waveform memory into analog signals.

Analog Processing (A3, Analog Board)

This analog processing block amplifies the analog signals from the DAC to the necessary amplitude. If an offset is specified, this circuit adds that offset and outputs the result at the output connector for that channel. This circuit also contains a filter, an AM modulator, and other elements that modify waveform output. Its output impedance is 50 Ω .

CPU and Memory (A6, CPU Board)

This functional block directs operation of all internal circuits, based on front panel control operation and commands received over the GPIB or RS-232-C interface. This circuit includes the 68000 CPU, DRAM, EPROM, and SRAM. Data in memory is retained by a lithium battery on the A5 Backplane board.



CAUTION. *To avoid losing waveform data files stored in NVRam, save the files to a floppy disk before removing the A6 CPU board or A5 Backplane board. Then restore the files from floppy disk to AWG2021 nonvolatile memory after reinstalling the board(s).*

GPIB (A6, CPU Board)

This functional block is the General Purpose Interface Bus (GPIB) interface driver, which controls communication with external devices over the parallel interface. The GPIB connector is on the rear panel.

RS-232-C (A6, CPU Board)

This functional block is the RS-232-C interface circuit which controls serial communication with external devices over the RS-232-C interface. The RS-232-C interface connector is on the rear panel.

Display Control (A6, CPU Board)

The display control block processes the test and waveform information based on commands from the processor. The block sends the text and waveform information to the display monitor as video signals, with vertical and horizontal sync control.

Display Monitor

This display monitor takes in the video signals and displays them on a 17.8 cm (7 in.) CRT screen. The display resolution is 480 \times 640 pixels.

Front Panel (A12, Keyboard)

The front panel block includes the buttons, keys, and knobs for entering selections. User selections from the front panel are sent to the processor. The buttons at the bottom and side of the display are also included in this block. Commands from the processor control an LED in the buttons.

Floppy Disk Drive	The 3.5-inch floppy disk drive supports both 2DD and 2HD MS-DOS formats.
Low Voltage Power Supply (A4 Power Board)	This functional block is a switching-type power supply that converts the line voltage into the voltages required for internal circuit operation. The Power board (A4) is also part of this block; it generates the voltage required for the analog circuits.
Fan	The fan prevents heat build-up inside the cabinet. It pulls air into the right (floppy-disk) side of the AWG2021 and exhausts it out the left side.

Options

The following three options are available on the AWG2021:

- **Option 02: Second Output Channel**
This option adds a second waveform output channel. It includes a Control board, Memory board, and an Analog board for Channel 2.
- **Option 03: ECL Digital Data Out**
This option directly outputs the ECL level digital data in the waveform memory without passing it through the digital-to-analog converter. This option cannot be installed with Option 04 or Option 09.
- **Option 04: TTL Digital Data Out**
This option directly outputs the TTL level digital data in the waveform memory without passing it through the digital-to-analog converter. This option cannot be installed with Option 03 or Option 09.
- **Option 09: Floating Point Processor**
This option provides increased internal calculation speed and two additional editors: an FFT editor and a convolution editor. This option cannot be installed with Option 03 or Option 04.

For more information about these and other options, see section 7, *Options*.

Performance Verification

Performance Verification Procedures

This section describes the verification procedures, indicates when to use the procedures, and gives conventions used in their structure. The procedures in this section are:

- Self Tests
- Performance Tests

Preparation

These procedures verify the AWG2021 Arbitrary Waveform Generator functionality. Which procedure to do depends on your goal:

- To quickly confirm that the AWG2021 functions correctly and was adjusted properly, do the procedures under *Self Tests*, which begin on page 4–3.

Advantages: These procedures are short, require no external equipment, and perform extensive functional and accuracy testing. Use them to quickly determine if the AWG2021 is suitable for putting into service, such as when it is first received.

- For a more extensive confirmation of performance, do the *Performance Tests*, beginning on page 4–7 after doing the *Self Tests*.

Advantages: These procedures involve direct checking of warranted specifications. They require more time and suitable test equipment. (See *Equipment Required* on page 4–8.)

Before starting any of these procedures, read *Instructions for Operation* in section 2 of this manual. These instructions briefly describe the AWG2021 front-panel controls and menu system. The user manual contains detailed information on operating the AWG2021.

Conventions

Throughout the procedures in this section, the following conventions apply:

- Each test procedure uses the following general format:

Title of Test
Equipment Required
Prerequisites
Procedure

- Each procedure consists of as many steps, substeps, and subparts as required to do the test. Steps, substeps, and subparts are sequenced as follows:
 1. First Step
 - a. First Substep
 - First Subpart
 - Second Subpart
 - b. Second Substep
 2. Second Step
- Instructions for menu selection follow this format: **FRONT PANEL BUTTON→Main Menu Button→Side Menu Button**. For example, “Press **UTILITY→Misc→Config...→Reset to Factory→O.K.**”
- Where instructed to use a front-panel button, key, or knob, or select from the MENU column, or from a bottom or side menu, the name of the item appears in boldface type: “push **MODE**,” or “select **Burst** in the bottom menu.”

Self Tests

This subsection describes how to use AWG2021 internal self-test routines. No equipment is required to do these procedures. The self tests include these internal routines:

- *Diagnostics.* This self-test procedure uses internal routines to verify that the AWG2021 functions, and passes the internal circuit tests.
- *Calibration.* The second procedure checks the AWG2021 internal calibration constants and changes them if needed.

Diagnostics

The internal diagnostic routines check AWG2021 characteristics such as amplitude, offset, trigger level, clock, filters, X5 output amplifier, and attenuation.

The AWG2021 automatically performs the internal diagnostics at power-on. You can also run the internal diagnostics using the menu selections described in this procedure. The difference between these two methods of initiating the diagnostics is that the menu method does more detailed memory checking than the power-on method.

Equipment Required	None
Prerequisites	Power on the AWG2021 and allow a 20-minute warmup period before doing this procedure.

1. *Verify that internal diagnostics pass:* Do the following substeps to verify passing internal diagnostics.
 - a. *Display the diagnostics menu and select all tests:* Push **UTILITY**→**Diag/Cal**→**Diagnostics xxxx**→**All**. See the menu in Figure 4–1.

The list on the left shows the tests available for diagnostics. In addition to selecting all of the tests shown for diagnostics, you can select only the test(s) you want to run using the general purpose knob. In Figure 4–1, the symbol to the left of Cpu indicates that test is one of the tests selected.

	Diagnostics	Result	Code
#	Cpu	Pass	
#	Clock	Pass	
#	Display	Pass	
	FPP	----	
#	FrontPanel	Pass	
#	Trigger	Pass	
#	Setup CH1	Pass	
	Setup CH2	----	
#	Waveform Memory CH1	Pass	
	Waveform Memory CH2	----	

Figure 4-1: Diagnostics Menu

- b. *Run the diagnostics:* Select **Execute** from the side menu. This executes all the AWG2021 diagnostics automatically.
 - c. *Wait:* The internal diagnostics do an extensive verification of AWG2021 functions. This verification takes about one minute. While it progresses, the screen displays the busy icon. When finished, the resulting status appears on the screen.
 - d. *Confirm that no failures are found:* Verify that no failures are found and reported on-screen. If the diagnostics displays Fail as the result of any test, use the instructions in section 6, *Troubleshooting*, to identify the faulty module. If the diagnostics display an error code, contact your nearest representative.
2. *Return to regular service:* Push a button (other than UTILITY) in the MENU column to exit the diagnostic menu.

Calibration

The AWG2021 includes internal calibration routines that check electrical characteristics such as amplitude, offset, trigger level, clock, filters, X5 output amplifier, and attenuation. The routine adjusts internal calibration constants as necessary. This procedure describes how to do the internal calibration.

Equipment Required	None.
Prerequisites	Power on the AWG2021 and allow a 20-minute warmup period before doing this procedure.

1. *Verify that internal adjustments pass:* Do the following substeps to verify passing of internal adjustments.
 - a. *Display the calibrations menu and select all tests:* Push **UTILITY**→**Diag/Cal**→**Calibrations xxxx**→**All**. See the menu in Figure 4–2.

	Calibrations	Result	Code
#	Trigger	Pass	
#	Setup CH1	Pass	
#	Setup CH2	---	
#	Clock	Pass	

Figure 4–2: Calibrations Menu

- b. *Run the calibrations routine:* Select **Execute** from the side menu. This executes the AWG2021 calibrations routine automatically.
- c. *Wait:* The internal calibration does an exhaustive verification of proper AWG2021 function. While it progresses, the busy icon appears on screen. When finished, the resulting status will appear on the screen.
- d. *Confirm that no failures are found:* Verify that no failures are found and reported on-screen. If the calibration displays Fail as the result, use the instructions in section 6, *Troubleshooting*, to identify the faulty module. If an error code is displayed, contact your nearest representative.

- 2. Return to regular service:* Push any button (other than UTILITY) in the MENU column to exit the diagnostic menu.

NOTE. *The interactive tests on the Diag/Cal menu are for manufacturing use at the factory.*

Performance Tests

This subsection contains a series of procedures for checking that the AWG2021 Arbitrary Waveform Generator performs as warranted.

The procedures are arranged in ten logical groupings, presented in the following order:

- Operating Mode Checks
- Arithmetic Operation Checks
- Clock Frequency and Amplitude Checks
- Gain and Offset Accuracy Checks
- Pulse Response Check
- SYNC Out and MARKER Out Amplitude Checks
- External Trigger Level Accuracy Check
- External CLOCK IN Check
- ECL Digital Data Out Check (Option 03)
- TTL Digital Data Out Check (Option 04)

These procedures extend the confidence level provided by the internal diagnostic and calibration routines described on page 4-3.

Prerequisites

The tests in this subsection comprise an extensive, valid confirmation of performance and functionality, when the following requirements are met:

- You must have performed and passed the calibration procedure described in *Self Tests* on page 4-5.
- The AWG2021 must have passed the calibration procedure mentioned above or must have been adjusted using the adjustment procedure in section 5 at an ambient temperature between +20° C and +30° C, must have been operating for a warm-up period of at least 20 minutes, and must be operating at an ambient temperature between +10° C and +40° C.

NOTE. For operation to specified accuracy, allow the AWG2021 to warm up at least 20 minutes before doing the performance tests.

- Load all the files from the Performance Check/Adjustment disk (063-2171-XX) that comes with this manual into AWG2021 internal memory. For instructions on loading files, see *Loading Files* on page 2–14 in the *Instructions for Operation* subsection in section 2.

Related Information Read *Preparation* and *Conventions* on page 4-1. Also, if you are not familiar with operating the AWG2021, read the subsection *Instructions for Operation*, in section 2 before doing any of these procedures.

Equipment Required The following equipment is required to check the performance of the AWG2021.

Table 4–1: Test Equipment

Item Description	Minimum Requirements	Example	Purpose
Precision termination	Impedance: 50 Ω , 0.1% Connectors: BNC	Tektronix Part 011-0129-XX	Signal termination.
Adapter	Connectors: BNC female-to-dual banana	Tektronix Part 103-0090-XX	Signal interconnection.
Adapter	Connectors: SMA male-to-BNC female	Tektronix Part 015-0554-XX	Signal interconnection.
BNC dual input (TEE) adapter	Connectors: BNC	Tektronix Part 103-0030-XX	Signal interconnection.
BNC cable (4 required)	Impedance: 50 Ω Connectors: BNC Length: 43 inches	Tektronix Part 012-0057-XX	Signal interconnection.
Termination board (Option 03)	Must use example equipment	Tektronix Part 671-2957-XX	Used to check ECL digital data output.
ECL Digital Data Out Cable (Option 03)	Must use example equipment	Tektronix Part 012-1408-XX (Standard accessory for Option 03)	Used to check ECL digital data output.
Test leads (Option 03)	Must use example equipment	Tektronix Part 012-1381-XX	Used to check ECL digital data output.
TTL Digital Data Out Cable (Option 04)	Must use example equipment	Tektronix Part 174-3192-XX (Standard accessory for Option 04)	Used to check TTL digital data output.
2 \times 13 header (Option 04)	Must use example equipment	Tektronix Part 131-3847-XX	Used to check TTL digital data output.
Probe, 10X (Option 04)	10X probe	Tektronix Part P6139A	Used to check TTL digital data output.
Test oscilloscope	Bandwidth: >250 MHz	Tektronix TDS500 Series Digitizing Oscilloscope or 2400 Series Digitizing Oscilloscope	Checks output signals. Used in many procedures.

Table 4–1: Test Equipment (Cont.)

Item Description	Minimum Requirements	Example	Purpose
Frequency counter	Frequency range: 10 Hz to 250 MHz	Tektronix DC 5010 Programmable Universal Counter/Timer*	Used to check clock frequency.
Digital multimeter	DC volts range: 0.05 V to 5 V Accuracy: $\pm 0.1\%$	Fluke 8842A	Used throughout the checks to measure voltage.
Function generator	Output voltage: -5 V to 5 V	Tektronix FG 5010 Programmable Function Generator*	Used to input the trigger signal.
Power supply (Option 03)	Output voltage: -2 V	Tektronix PS 2510 Programmable Power Supply	Used to check ECL digital data output.
Performance Check/Adjustment disk	Must use example listed	Tektronix Part 063-2171-00	Used throughout the checks to provide waveform files.

* Requires a TM 5000 Series Power Module Mainframe

Performance Check/Adjustment Files

Table 4–2 lists the waveform files on the Performance Check/Adjustment disk (063-2171-XX) that are used in these performance test. It describes the AWG2021 front-panel settings that each file sets up, and the performance test that uses each file.

NOTE. *The files on the Performance Check/Adjustment disk are locked (the files names are displayed with *), so the data in these files cannot be changed unless the lock is opened. The file data includes not only waveform data, but also output parameters.*

When you select a file with the Waveform Sequence item, the AWG2021 output parameters change to those specified in the file, and the waveform output reflects waveform data in the file. After selecting a file, do not change an output parameter with the SETUP menu unless a procedure instructs you to do so. During the procedures, if you are unsure that the AWG2021 settings still match the file's settings, select the waveform again using the Waveform Sequence item on the SETUP menu.

Table 4-2: File List for Performance Check/Adjustment Disk







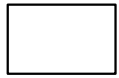

No.	File Name	EDIT Menu		SETUP Menu					Usage
		Wfm Shape	Wfm Point	Clock	Operation	Filter	Ampl	Offset	
1	MODE.WFM		1000	1 MHz	Normal	Through	1 V	0 V	Cont Mode, Triggered Mode, Burst Mode, Gated Mode
2	MODE_ADV.SEQ ADV-1.WFM ADV-2.WFM		1200 1000 200	100 MHz	Normal	Through	1 V	0 V	Waveform Advance Mode
3	MODE_AST.AST Step: 1 AST-1.WFM		100	250 kHz	Normal	Through	3 V	0 V	Autostep Mode
	Step: 2 AST-2.WFM		200	150 kHz	Normal	Through	1.5 V	0 V	
	Step: 3 AST-3.WFM		200	25 kHz	Normal	Through	0.5 V	0 V	
4	OPE.AST Step: 1 EXT_AM.WFM (CH1)		1000	1 MHz	External AM	Through	5 V	0 V	External AM Operation
	Step: 2 AM-1.WFM (CH1)		1000	1 MHz	AM	Through	5 V	0 V	Internal AM Operation
	AM-2.WFM (CH2)		1000	1 MHz	—	Through	5 V	2.5 V	
	Step: 3 AM-1.WFM (CH1)		1000	1 MHz	AM	Through	5 V	0 V	Internal Add Operation
	AM-3.WFM (CH2)		1000	1 MHz	—	Through	5 V	-2.5 V	
	Step: 4 ADD.WFM (CH1)		1000	1 MHz	Add	Through	5 V	0 V	
		ADD.WFM (CH2)		1000	1 MHz	—	Through	5 V	0 V
5	CLK_FREQ.WFM		1000	250 MHz	Normal	Through	1 V	0 V	Clock Frequency Accuracy
6	CLK_AMPL.WFM		1000	1 MHz	Normal	Through	1 V	0 V	Clock Amplitude

Table 4-2: File List for Performance Check/Adjustment Disk (Cont.)

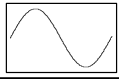
No.	File Name	EDIT Menu		SETUP Menu					Usage
		Wfm Shape	Wfm Point	Clock	Operation	Filter	Ampl	Offset	
7	GAIN_OFF.AST Step: 1 GAIN-1.WFM		1000	1 MHz	Normal	Through	0.25 V	0 V	Gain Accuracy
	Step: 2 GAIN-2.WFM		1000	1 MHz	Normal	Through	0.25 V	0 V	
	Step: 3 GAIN-3.WFM		1000	1 MHz	Normal	Through	2.5 V	0 V	
	Step: 4 GAIN-4.WFM		1000	1 MHz	Normal	Through	2.5 V	0 V	
	Step: 5 OFFSET-1.WFM		1000	1 MHz	Normal	Through	0.05 V	1.25 V	Offset Accuracy
	Step: 6 OFFSET-2.WFM		1000	1 MHz	Normal	Through	0.05 V	1.25 V	
	Step: 7 OFFSET-3.WFM		1000	1 MHz	Normal	Through	0.05 V	-1.25 V	
8	PULSE.WFM		64	250 MHz	—	Through	0.5 V	0 V	Pulse Response
9	SYNC_MKR.WFM		200	1 MHz	—	Through	1 V	0 V	SYNC Out and MARKER OUT Amplitude
10	TRG_IN.WFM		1000	100 MHz	—	Through	1 V	0 V	External Trigger Level Accuracy
11	EXT_CLK.WFM		1000	External Clock	—	Through	1 V	0 V	External Clock In
12	DIGI_OUT.WFM		4096	1 MHz	Normal	Through	1 V	0 V	ECL and TTL DIGITAL DATA OUT Check (Option 03 and 04)

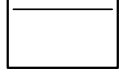
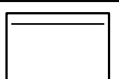
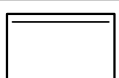
Operating Mode Checks

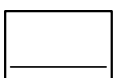
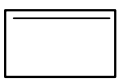
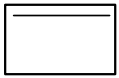
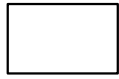
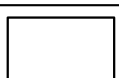
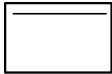
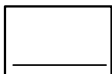
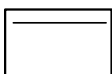
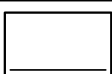
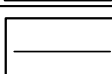
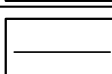
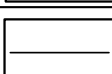
These procedures check operation of the Cont, Triggered, Burst, Gated, Waveform Advance, and Autostep modes.

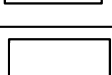
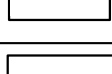
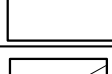
Check Cont Mode

Electrical Characteristic Checked	Operating mode, Continuous, on page 1-4.
Equipment Required	One 50 Ω coaxial cable One oscilloscope
Prerequisites	The AWG2021 must meet the prerequisites listed on page 4-7.

1. *Install the test hookup and set test equipment controls:*

- a. *Hook up the oscilloscope:* Connect the AWG2021 CH1 output connector through the coaxial cable to the CH1 vertical input connector on the oscilloscope (see Figure 4-3).

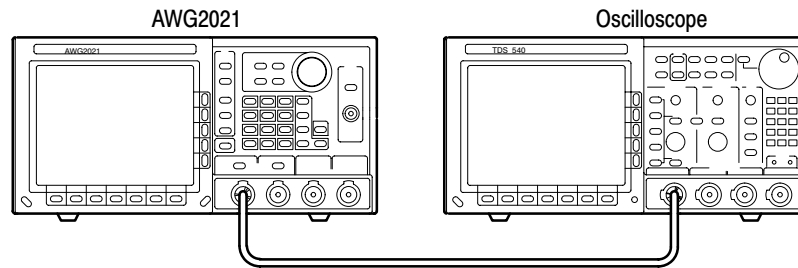

Figure 4-3: Cont Mode Initial Test Hookup

- b. *Set the oscilloscope controls:*

Vertical CH1
 CH1 coupling: DC
 CH1 scale 0.2 V/div.
 CH1 input impedance: 50 Ω
 Horizontal
 Sweep 500 μ s/div.
 Trigger
 Source CH1
 Coupling DC
 Slope Positive
 Level +100 mV
 Mode Auto

2. *Set the AWG2021 controls and select the waveform file:*
 - a. *Initialize AWG2021 controls:* Push **UTILITY**→**Misc**→**Config...**→**Reset to Factory**→**O.K.**
 - b. *Select the file:*
 - Push **SETUP**→**Waveform Sequence**, if necessary, to select a waveform file for CH1. Waveform Sequence toggles between the CH1 files (upper list) and the CH2 files (lower list).
 - Turn the general purpose knob to display the list of waveform files and highlight the **MODE.WFM** file.
 - Push **ENTER** to select the file. This button is located to the lower-right of the numeric keypad.
3. *Turn on the AWG2021 CH1 output:* Push the **CH1** button so that the LED above the CH1 output connector is on.
4. *Check cont mode:* Check that the amplitude of the sine wave displayed on the oscilloscope is 5 vertical divisions and that 5 cycles of the waveform are displayed.
5. *If Option 02 is installed (Option 02 adds the CH2 output channel):* Repeat this procedure, connecting the oscilloscope to the AWG2021 CH2 output connector, pushing **Waveform Sequence** to select the waveform for CH2, and turning on the CH2 output.
6. *End procedure:* Disconnect the oscilloscope.

Check Triggered Mode

Electrical Characteristic Checked	Operating mode, Triggered, on page 1-4.
Equipment Required	Two 50 Ω coaxial cables One function generator One oscilloscope
Prerequisites	The AWG2021 meets the prerequisites listed on page 4-7.

1. *Install the test hookup and set test equipment controls:*
 - a. *Hook up the oscilloscope:* Connect the AWG2021 CH1 output connector through the coaxial cable to the CH1 vertical input connector on the oscilloscope.
 - b. *Hook up the function generator:*
 - Connect the AWG2021 TRIGGER INPUT connector through a coaxial cable to the function generator output connector (see Figure 4-4).

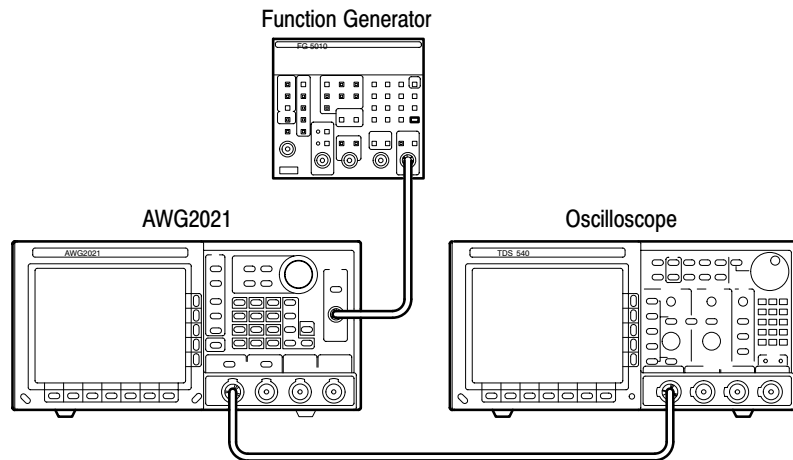

Figure 4-4: Triggered Mode Initial Test Hookup

- c. *Set the oscilloscope controls:*

Vertical CH1
 CH1 coupling: DC
 CH1 scale 0.2 V/div.
 CH1 input impedance: 50 Ω
 Horizontal
 Sweep 500 μs/div.

Trigger
 Source CH1
 Coupling DC
 Slope Positive
 Level +100 mV
 Mode Norm

d. *Set the function generator controls:*

Function Square
 Mode Continuous
 Parameter
 Frequency 100 Hz
 Amplitude 4 V
 Offset 2 V
 Output Off

2. *Set AWG2021 controls and select the waveform file:*

a. *Initialize AWG2021 controls:* Push **UTILITY**→**Misc**→**Config...**→**Reset to Factory**→**O.K.**

b. *Modify the AWG2021 default settings:*

- Push **MODE**→**Triggered**→**Slope** to select Positive slope.
- Select **Level** from the side menu and turn the general purpose knob to select a 1 V trigger level.
- Select **Impedance** from the side menu to select 50 Ω impedance.

c. *Select the file:*

- Push **SETUP**→**Waveform Sequence**, if necessary, to select a waveform file for CH1. Waveform Sequence toggles between the CH1 files (upper list) and the CH2 files (lower list).
- Highlight the **MODE.WFM** file using the general purpose knob.
- Push **ENTER** to select the file.

3. *Turn on the AWG2021 CH1 output:* Push the **CH1** button so that the LED above the CH1 output connector is on.

4. *Check triggered mode with manual triggering:* Push the AWG2021 **MANUAL TRIGGER** button and check that when the button is pushed, the oscilloscope displays a one-cycle sine wave.

5. *Check triggered mode with external triggering:*
 - a. *Enable function generator output:* Turn on the function generator output.
 - b. *Check triggering:* Check that for each trigger supplied by the function generator, the oscilloscope displays a one-cycle sine wave.
6. *End procedure:* Turn off the function generator output, and disconnect the function generator and oscilloscope.

Check Burst Mode

Electrical Characteristic Checked	Operating mode, Burst, on page 1–4.
Equipment Required	One 50 Ω coaxial cable One oscilloscope
Prerequisites	The AWG2021 meets the prerequisites listed on page 4–7.

1. *Install test hookup and set test equipment controls:*
 - a. *Hook up the oscilloscope:* Connect the AWG2021 CH1 output connector through the coaxial cable to the CH1 vertical input connector on the oscilloscope (see Figure 4–5).

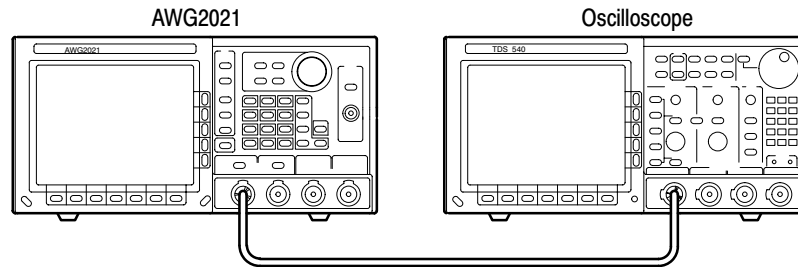

Figure 4–5: Burst Mode Initial Test Hookup

- b. *Set the oscilloscope controls:*
 - Vertical CH1
 - CH1 coupling: DC
 - CH1 scale 0.2 V/div.
 - CH1 input impedance: 50 Ω
 - Horizontal
 - Sweep 500 μ s/div.
 - Trigger
 - Source CH1
 - Coupling DC
 - Slope Positive
 - Level +100 mV
 - Mode Norm

2. *Set AWG2021 controls and select the waveform file:*
 - a. *Initialize AWG2021 controls:* Push **UTILITY**→**Misc**→**Config...**→**Reset to Factory**→**O.K.**
 - b. *Modify the AWG2021 default settings:* Push **MODE**→**Burst**→**Burst Count** and turn the general purpose knob to a burst count of 3.
 - c. *Select the file:*
 - Push **SETUP**→**Waveform Sequence**, if necessary, to select a waveform file for CH1. Waveform Sequence toggles between the CH1 files (upper list) and the CH2 files (lower list).
 - Turn the general purpose knob to highlight the **MODE.WFM** file.
 - Push **ENTER** to select the file.
3. *Turn on the AWG2021 CH1 output:* Push the **CH1** button so that the LED above the CH1 output connector is on.
4. *Check burst count:* Push the AWG2021 **MANUAL TRIGGER** button and check that when the button is pushed, the oscilloscope displays three cycles of sine wave.
5. *End procedure:* Disconnect the oscilloscope.

Check Gated Mode

Electrical Characteristic Checked	Operating mode, Gated, on page 1-4.
Equipment Required	Three 50 Ω coaxial cables One 50 Ω precision termination One function generator One oscilloscope
Prerequisites	The AWG2021 meets the prerequisites listed on page 4-7.

1. Install test hookup and set test equipment controls:

- a. *Hook up the oscilloscope:* Connect the AWG2021 CH1 output connector through the coaxial cable to the CH1 vertical input connector on the oscilloscope.
- b. *Hook up the function generator:* Connect the function generator output to both the AWG2021 TRIGGER INPUT and the oscilloscope CH2 input through a coaxial cable, precision termination, and a dual input coupler (see Figure 4-6).

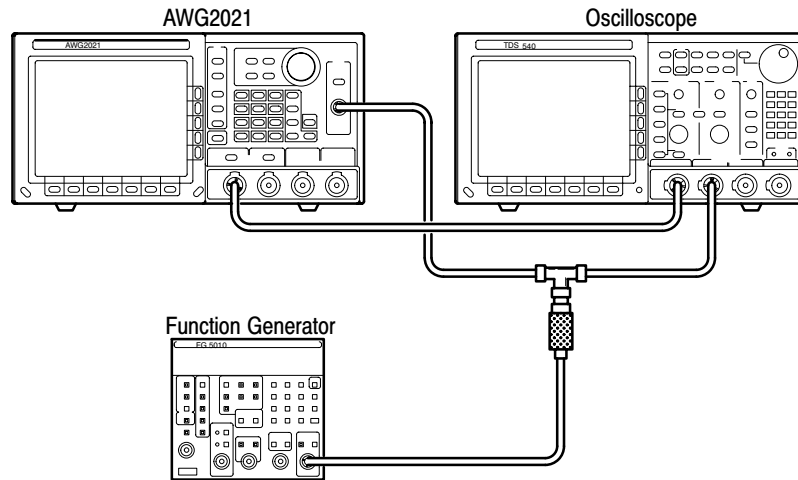

Figure 4-6: Gated Mode Initial Test Hookup

c. Set oscilloscope controls:

- Vertical CH1, CH2
- CH1, CH2 coupling DC
- CH1, CH2 scale 0.5 V/div.
- CH1 input impedance 50 Ω
- CH2 input impedance 1 MΩ
- Mode Chop

Horizontal	
Sweep	2 ms/div.
Trigger	
Source	CH2
Coupling	DC
Slope	Positive
Level	500 mV
Mode	Auto

d. *Set function generator controls:*

Function	Square
Mode	Continuous
Parameter	
Frequency	100 Hz
Amplitude	4.0 V
Offset	2.0 V
Output	Off

2. *Set the AWG2021 controls and select the waveform file:*

a. *Initialize AWG2021 controls:* Push **UTILITY**→**Misc**→**Config...**→**Reset to Factory**→**O.K.**

b. *Modify the AWG2021 default settings:*

- Push **MODE**→**Gated**→**Polarity** to highlight Positive.
- Select **Impedance** from the side menu to highlight 1 M Ω .

c. *Select the file:*

- Push **SETUP**→**Waveform Sequence**, if necessary, to select a waveform file for CH1. Waveform Sequence toggles between the CH1 files (upper list) and the CH2 files (lower list).
- Highlight the **MODE.WFM** file, using the general purpose knob.
- Push **ENTER** to select the file.

3. *Turn on the AWG2021 CH1 output:* Push the **CH1** button so that the LED above the CH1 output connector is on.

4. *Check gated mode with manual trigger:* Push and hold the AWG2021 **MANUAL TRIGGER** button, and check that the oscilloscope continuously displays a sine wave while the **MANUAL TRIGGER** button is pushed.

5. *Check gated mode with gate signal:*

- a. *Apply gate signal:* Turn function generator output on.
- b. *Check gated mode with positive gate signal:* Check that the oscilloscope displays a sine wave while the function generator gate signal amplitude is high (see Figure 4-7).

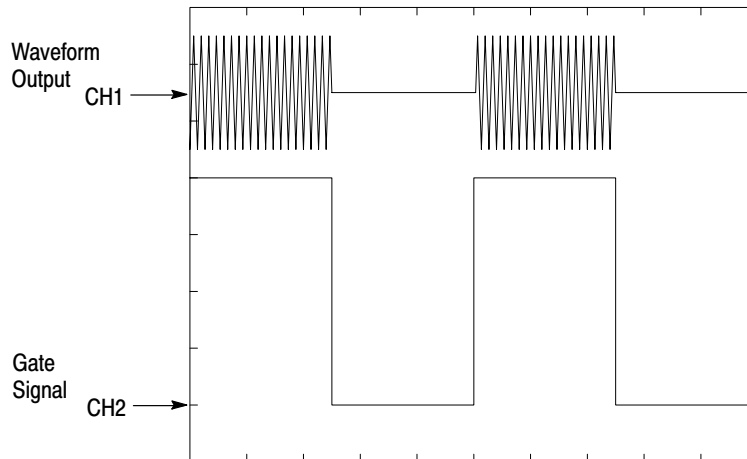

Figure 4-7: Relationship Between 1 Volt or Greater Gate Signal and Waveform Output Signal

- c. *Change the AWG2021 trigger polarity to negative:* Push **MODE**→**Polarity** to change the polarity to Negative.
 - d. *Check gated mode with a negative gate signal:* Check that the oscilloscope displays a sine wave while the function generator gate signal amplitude is low.
6. *End procedure:* Turn the function generator output off and disconnect the function generator.

Check Waveform Advance Mode

Electrical Characteristic Checked	Operating mode, Waveform Advance, on page 1–4.
Equipment Required	One 50 Ω coaxial cable One oscilloscope
Prerequisites	The AWG2021 meets the prerequisites listed on page 4–7.

1. Install test hookup and set test equipment controls:

- a. Hook up the oscilloscope:** Connect the AWG2021 CH1 output connector through the coaxial cable to the CH1 vertical input connector on the oscilloscope (see Figure 4–8).

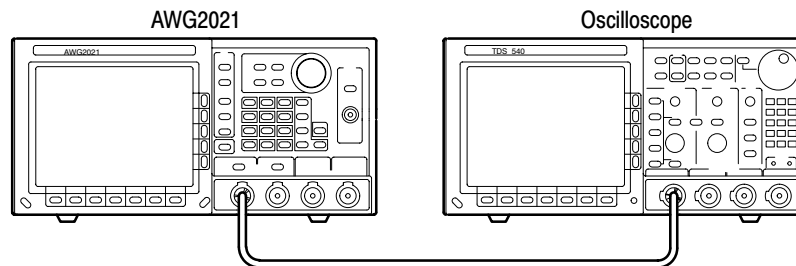
**Figure 4–8: Waveform Advance Mode Initial Test Hookup****b. Set oscilloscope controls:**

Vertical CH1
 CH1 coupling DC
 CH1 0.2 V/div.
 CH1 input impedance 50 Ω
 Horizontal
 Sweep 5 μ s/div.
 Trigger
 Source CH1
 Coupling DC
 Slope Positive
 Level 0 V
 Mode Auto

2. Set the AWG2021 controls and select the waveform file:

- a. Initialize AWG2021 controls:** Push **UTILITY**→**Misc**→**Config...**→**Reset to Factory**→**O.K.**

b. *Set AWG2021 controls:*

- Push **MODE**→**Waveform Advance**→**Slope** to highlight Positive.
- Select **Level** from the side menu, and turn the general purpose knob to select a 1.0 V level.
- Select **Impedance** from the side menu to highlight 50 Ω .

c. *Select waveform file:*

- Push **SETUP**→**Waveform Sequence**, if necessary, to select a waveform file for CH1. Waveform Sequence toggles between the CH1 files (upper list) and the CH2 files (lower list).
- Highlight the **MODE_ADV.SEQ** file using the general purpose knob.
- Push **ENTER** to select the file.

- 3.** *Turn on the AWG2021 CH1 output:* Push the **CH1** button so that the LED above the CH1 output connector is on.
- 4.** *Check waveform advance:* Repeatedly push the AWG2021 **MANUAL TRIGGER** button, and check that the oscilloscope displays a continuous sine wave that switches between two frequencies at each manual trigger.
- 5.** *End procedure:* Disconnect the oscilloscope.

Check Autostep Mode

Electrical Characteristic Checked	Operating mode, Autostep, on page 1-4.
Equipment Required	Two 50 Ω coaxial cables One oscilloscope
Prerequisites	The AWG2021 meets the prerequisites listed on page 4-7.

1. Install test hookup and set test equipment controls:**a. Hook up the oscilloscope:**

- Connect the AWG2021 CH1 output through a coaxial cable to the oscilloscope CH1 vertical input.
- Connect the AWG2021 CH1 SYNC Out output through a coaxial cable to the oscilloscope CH2 vertical input (see Figure 4-9).

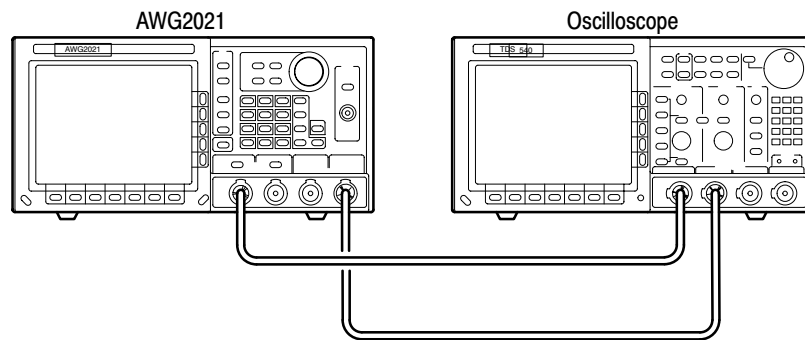
**Figure 4-9: Autostep Mode Initial Test Hookup****b. Set the oscilloscope controls:**

Vertical	CH1
CH1 coupling	DC
CH1 scale	0.5 V/div.
CH1 input impedance	50 Ω
Horizontal	
Sweep	2 ms/div.
Trigger	
Source	CH2
Coupling	DC
Slope	Positive
Level	100 mV
Mode	Normal

2. *Set the AWG2021 controls and select the waveform file:*
 - a. *Initialize AWG2021 controls:* Push **UTILITY**→**Misc**→**Config...**→**Reset to Factory**→**O.K.**
 - b. *Modify AWG2021 default settings:*
 - Push **MODE**→**Autostep**→**Slope** to highlight Positive.
 - Select **Level** from the side menu, and turn the general purpose knob to select 1 V.
 - Select **Select Autostep File** from the side menu to choose from the file list for CH1.
 - Turn the general purpose knob to highlight the **MODE_AST.AST** file.
 - Push **ENTER**.
 - Select **Start** within the **Sync** frame at the bottom menu.
3. *Turn on the AWG2021 CH1 output:* If the LED above the CH1 output connector is not on, push the **CH1** button.
4. *Check autostep mode:* Push the AWG2021 **MANUAL TRIGGER** button, and check that the oscilloscope momentarily displays one cycle sine wave with a different frequency and amplitude each time you push and release the button.
5. *End procedure:* Disconnect the oscilloscope.

Arithmetic Operation Checks

These procedures check operation of external AM. For an AWG2021 with Option 02, the procedures check internal AM and internal ADD arithmetic functions.

NOTE. *The arithmetic operation checks are structured as a continuous series of tests. After Check External AM Operation, each test uses the control settings from the last test, and the next step in the sequence file.*

Check External AM Operation

Electrical Characteristic Checked	External amplitude modulation, page 1–12.
Equipment Required	Two 50 Ω coaxial cables One 50 Ω terminator One function generator One digital multimeter (DMM)
Prerequisites	The AWG2021 meets the prerequisites listed on page 4–7.

1. *Install test hookup and set test equipment controls:*

- a.** *Hook up DMM:* Connect the AWG2021 CH1 output through a coaxial cable, the 50 Ω terminator, and BNC-to-dual banana connector to the DMM INPUT connector.
- b.** *Hook up function generator:* Connect the AWG2021 rear-panel AM IN input through a coaxial cable to the function generator output (see Figure 4–10).
- c.** *Set DMM controls:*

Mode VDC
Range 20
Inputs Front

- d.** *Set function generator controls:*

Function Square
Mode Continuous
Parameter
 Frequency 1 kHz
 Amplitude 0 V
 Offset 1 V
Output Off

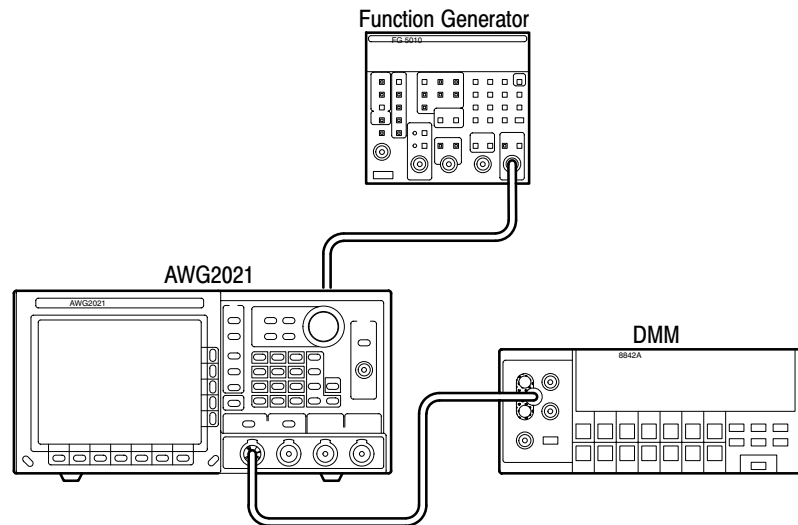

Figure 4-10: External AM Operation Initial Test Hookup

2. *Set the AWG2021 controls and select the waveform file:*
 - a. *Initialize AWG2021 controls: Push **UTILITY**→**Misc**→**Config...**→**Reset to Factory**→**O.K.***
 - b. *Modify AWG2021 default settings:*
 - Push **MODE**→**Autostep**.
 - c. *Select waveform file:*
 - Select **Select Autostep File** from the side menu to choose a waveform file for CH1.
 - Turn the general purpose knob to highlight the **OPE.AST** file.
 - Push **ENTER**.
3. *Turn on the AWG2021 CH1 output: If the LED above the CH1 output connector is not on, push the **CH1** button.*
4. *Enable the function generator output: Turn on the function generator output.*
5. *Check external AM operation:*
 - Check that the step number displayed on the AWG2021 MODE menu is **Step 1** (see Figure 4-11). If it is not, push **MANUAL TRIGGER** to step through the sequence file steps until Step: 1 is displayed.

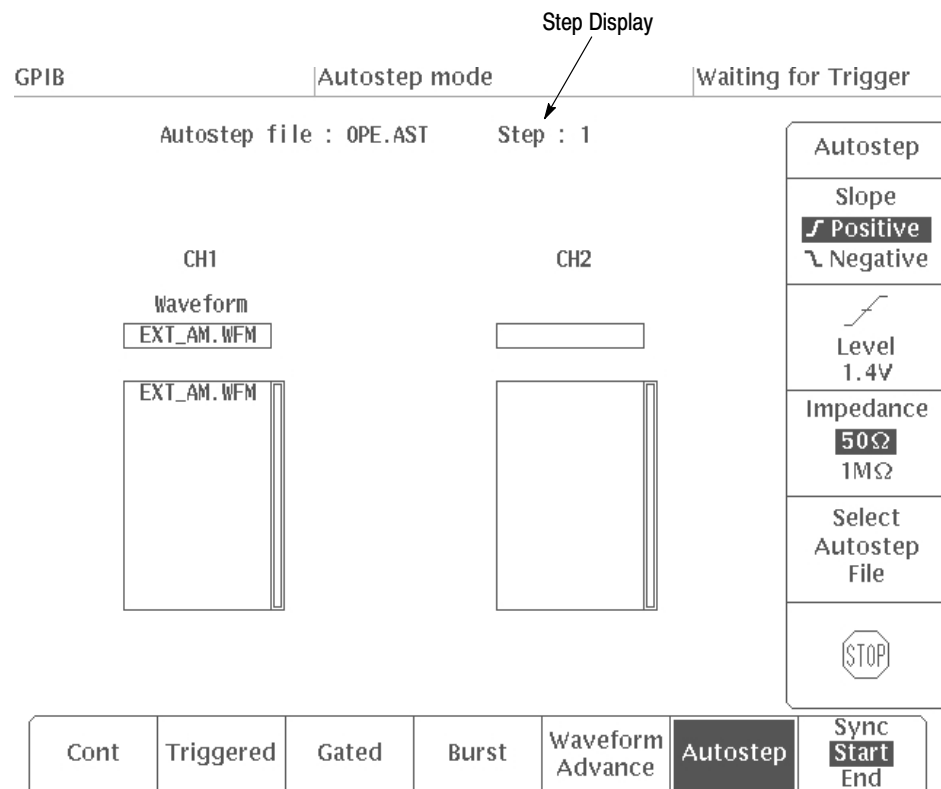

Figure 4-11: MODE Menu Autostep Setting

- Check that the DMM reading is in the range from +2.375 to +2.625 V (100% modulation).
 - Set the function generator offset value to 0 V. Check that the DMM reading is in the range from +1.125 to +1.375 V (50% modulation).
 - Set the function generator offset value to -1 V. Check that the DMM voltage reading is in the range from -0.125 to +0.125 V (0% modulation).
6. *End procedure:* Keep the test connections and instrument settings for the next check.

**Check Internal AM
Operation (Option 02
Only)**

Electrical Characteristic Checked	Arithmetic Operation, Amplitude Modulation, on page 1–12.
Equipment Required	Two 50 Ω coaxial cables One function generator One digital multimeter (DMM)
Prerequisites	The AWG2021 meets the prerequisites listed on page 4–7. Option 02 (CH2 output channel) must be installed in the AWG2021.

1. *Use the test hookup and control settings from the previous check.*
2. *Check internal AM operation:*
 - a. *Check Autostep Step 2:*
 - Push the AWG2021 **MANUAL TRIGGER** button, and check that the step changes to Step: 2 on the MODE menu.
 - Check that the DMM reading is in the range from +2.375 VDC to +2.625 VDC.
 - b. *Check Autostep Step 3:*
 - Push the AWG2021 **MANUAL TRIGGER** button, and check that the Autostep changes to Step: 3 on the MODE menu.
 - Check that the DMM reading is in the range from –2.625 V to –2.375 V.
3. *End procedure:* Retain the test hookup and settings for the next check.

**Check Internal Add
Operation (Option 02
Only)**

Electrical Characteristic Checked	Arithmetic Operation, Add, on page 1–13.
Equipment Required	Two 50 Ω coaxial cables One function generator One digital multimeter (DMM)
Prerequisites	The AWG2021 meets the prerequisites listed on page 4–7. Option 02 (CH2 output channel) must be installed in the AWG2021.

1. *Use the test hookup and control settings from the previous check.*
2. *Check internal Add operation:*
 - a. *Check Autostep Step 4:*
 - Push the AWG2021 **MANUAL TRIGGER** button, and check that the step changes to Step: 4 on the MODE menu.
 - Check that the DMM reading is in the range from +2.85 V to +3.15 V.
3. *End procedure:*
 - a. *Disable function generator output:* Turn off the function generator output.
 - b. *Remove equipment:* Disconnect connections to the test equipment.

Clock Frequency and Amplitude Checks

These procedures check the accuracy of the AWG2021 clock frequency and the waveform output amplitude.

Check Clock Frequency Accuracy

Electrical Characteristic Checked	Clock Generator, Accuracy, on page 1–9.
Equipment Required	A 50 Ω coaxial cable One SMA-BNC adapter One frequency counter
Prerequisites	The AWG2021 meets the prerequisites listed on page 4–7.

1. *Install test hookup and set test equipment controls:*
 - a. *Hook up frequency counter:* Connect the AWG2021 rear panel CLOCK OUT connector to the frequency counter input through a coaxial cable and an SMA-BNC adapter (see Figure 4–12).

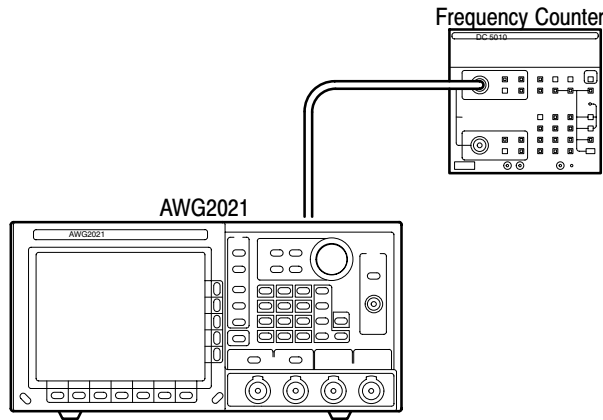

Figure 4–12: Clock Frequency Accuracy Initial Test Hookup

- b. *Set frequency counter controls:*

CHANNEL A
 Termination 50 Ω
 Slope Negative
 Attenuation X5
 Coupling AC
 FREQ A

2. *Set AWG2021 controls and select the waveform:*
 - a. *Initialize AWG2021 controls:* Push **UTILITY**→**Misc**→**Config...**→**Reset to Factory**→**O.K.**
 - b. *Select the waveform file:*
 - Push **SETUP**→**Waveform Sequence**, if necessary, to select a waveform file for CH1. Waveform Sequence toggles between the CH1 files (upper list) and the CH2 files (lower list).
 - Turn the general purpose knob to select the **CLK_FREQ.WFM** file.
 - Push **ENTER**.
3. *Check clock frequency accuracy:*
 - a. *Check clock frequency accuracy at current clock frequency setting:*
Check that the frequency counter reading falls between 249.9875 MHz and 250.0125 MHz.
 - b. *Check clock frequency accuracy for different clock frequency settings:*
 - Select **Clock/Divider** from the bottom of the SETUP menu, or select **Clock** if the instrument is not equipped with Option 02.
 - Turn the general purpose knob (or press the numeric and units keys, and push **ENTER**) to select the first clock frequency listed in Table 4-3.
 - Check that the frequency counter reading is within the frequency range listed in the table for the clock frequency setting.
 - Repeat this step for each clock frequency and frequency range listed in Table 4-3.

Table 4-3: Clock Frequency Accuracy

Clock Frequency	Frequency Range
150 MHz	149.9925 MHz – 150.0075 MHz
1 MHz	0.99995 MHz – 1.00005 MHz
1 kHz	0.99995 kHz – 1.00005 kHz
10 Hz	9.9995 Hz – 10.0005 Hz

4. *End procedure:* Disconnect the frequency counter.

Check Clock Amplitude

Electrical Characteristic Checked	Auxiliary Outputs, Clock, Amplitude, on page 1-11.
Equipment Required	A 50 Ω coaxial cable One SMA-BNC adapter One oscilloscope
Prerequisites	The AWG2021 meets the prerequisites listed on page 4-7.

1. *Install test hookup and set test equipment controls:*

- a. *Hook up oscilloscope:* Connect the AWG2021 rear-panel CLOCK OUT connector through a coaxial cable and SMA-BNC adapter to the oscilloscope CH1 vertical input (see Figure 4-13).

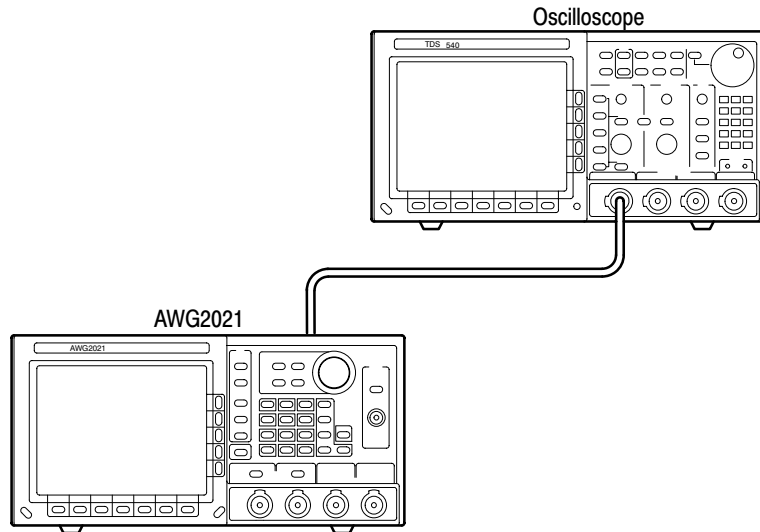

Figure 4-13: Clock Amplitude Initial Test Hookup

b. *Set oscilloscope controls:*

- Vertical CH1
- Coupling DC
- Scale 500 mV/div.
- Input impedance 50 Ω
- Horizontal
- Sweep 500 ns/div.

Trigger
Source CH1
Coupling DC
Slope Positive
Level 500 mV
Mode Auto

2. *Set the AWG2021 controls and select the waveform file:*
 - a. *Initialize AWG2021 controls:* Push **UTILITY**→**Misc**→**Config...**→**Reset to Factory**→**O.K.**
 - b. *Select the waveform file:*
 - Push **SETUP**→**Waveform Sequence**, if necessary, to select a waveform file for CH1. Waveform Sequence toggles between the CH1 files (upper list) and the CH2 files (lower list).
 - Turn the general purpose knob to select the **CLK_AMPL.WFM** file.
 - Push **ENTER**.
3. *Check clock amplitude accuracy:* Check that the pulse displayed on the oscilloscope has an amplitude of $0.7 V_{p-p}$ to $1.3 V_{p-p}$.
4. *End procedure:* Disconnect the oscilloscope.

Gain and Offset Accuracy Checks

These procedures check the accuracy of the AWG2021 gain and offset.

NOTE. *The gain and offset accuracy checks are structured as a continuous test. After Check Gain Accuracy, the next test uses the control settings from the last test, and the next step in the sequence file.*

Check Gain Accuracy

Electrical Characteristic Checked	Main Output, Amplitude, Accuracy, on page 1-9.
Equipment Required	A 50 Ω coaxial cable A 50 Ω termination One BNC-to-dual banana adapter One digital multimeter (DMM)
Prerequisites	The AWG2021 meets the prerequisites listed on page 4-7.

1. *Install test hookup and set controls:*
 - a. *Hook up DMM:* Connect the AWG2021 CH1 output through a 50 Ω coaxial cable, a 50 Ω termination and a dual banana connector to the DMM INPUT connector (see Figure 4-14).

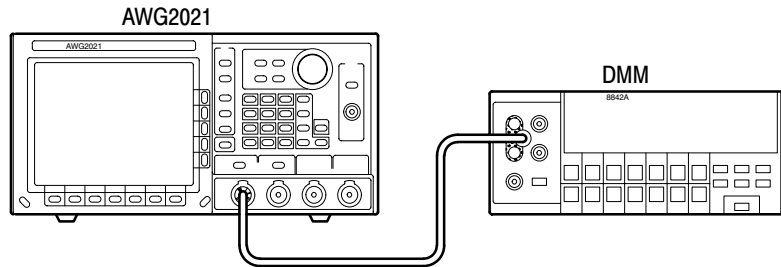

Figure 4-14: Gain Accuracy Initial Test Hookup

- b. *Set DMM controls:*

Mode	VDC
Range	20
Input	Front

2. *Set the AWG2021 controls and select the waveform file:*
 - a. *Initialize AWG2021 controls:* Push **UTILITY**→**Mis**→**Config...**→**Reset to Factory**→**O.K.**
 - b. *Select the AWG2021 waveform file:*
 - Push **MODE**→**Autostep**→**Select Autostep File** to choose a sequence file for CH1.
 - Turn the general purpose knob to select the **GAIN_OFF.AST** file.
 - Push **ENTER**.
3. *Check gain accuracy:*
 - Check that the displayed step is Step 1 on the MODE menu. If it is not, select the side menu STOP button to return to Step 1.
 - Note the DMM reading as “A” for this value.
 - Push the AWG2021 **MANUAL TRIGGER** button, and check that the displayed step is Step 2.
 - Note the DMM reading as “B” for this value.
 - Do the following calculation.
$$A - B$$
 - Check that the calculated value is in the range from 0.4925 V to 0.5075 V.
 - Push the AWG2021 **MANUAL TRIGGER** button, and check that the displayed step is Step 3.
 - Note the DMM reading as “C” for this value.
 - Push the AWG2021 **MANUAL TRIGGER** button, and check that the displayed step is Step 4.
 - Note the DMM reading as “D” for this value.
 - Do the following calculation.
$$C - D$$
 - Check that the calculated value is in the range from 4.925 V to 5.075 V
4. *End procedure:* Retain the test hookup and control settings.

Check Offset Accuracy

Electrical Characteristic Checked	Main Output, Offset, Accuracy, on page 1–9.
Equipment Required	One 50 Ω coaxial cable One 50 Ω termination One BNC-to-dual banana adapter One digital multimeter (DMM)
Prerequisites	The AWG2021 meets the prerequisites listed on page 4–7.

1. *Use the test hookup and test equipment settings from the previous check.*
2. *Check offset accuracy:*
 - Push the AWG2021 **MANUAL TRIGGER** button, and check that the displayed step is Step 5.
 - Check that the DMM voltage reading is in the range from +2.470 V to +2.530 V.
 - Push the AWG2021 **MANUAL TRIGGER** button, and check that the displayed step is Step 6.
 - Check that the DMM voltage reading is in the range from –0.005 V to +0.005 V.
 - Push the AWG2021 **MANUAL TRIGGER** button, and check that the displayed step is Step 7.
 - Check that the DMM voltage reading is in the range from –2.530 V to –2.470 V.
3. *Check Option 02: If the AWG2021 has Option 02, repeat the *Gain Accuracy* and *Offset Accuracy Checks* for the AWG2021 channel 2 (CH2).*
4. *End procedure: Disconnect the DMM.*

Pulse Response Check

This procedure checks the pulse response characteristics of the AWG2021 output waveforms at amplitudes of 0.5 V and 1 V.

Electrical Characteristic Checked	Main Outputs, Pulse Response, on page 1–10.
Equipment Required	One 50 Ω coaxial cable One oscilloscope
Prerequisites	The AWG2021 meets the prerequisites listed on page 4–7.

1. Install test hookup and set test equipment controls:

- a. Hook up the oscilloscope:** Connect the AWG2021 CH1 output connector through the coaxial cable to the CH1 vertical input connector on the oscilloscope (see Figure 4–15).

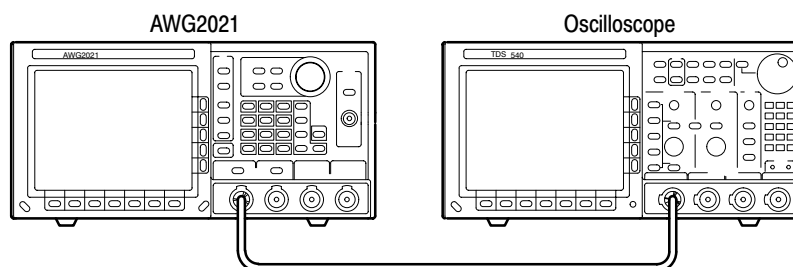

Figure 4–15: Pulse Response Initial Test Hookup

b. Set oscilloscope controls:

Vertical CH1
 Coupling DC
 Scale 0.1 V/div.
 Input impedance 50 Ω
 Horizontal
 Sweep 5 ns/div.
 Trigger
 Source CH1
 Coupling DC
 Slope Positive
 Level 0 V
 Mode Auto

2. *Set the AWG2021 controls and select the waveform file:*
 - a. *Initialize AWG2021 controls:* Push **UTILITY**→**Misc**→**Config...**→**Reset to Factory**→**O.K.**
 - b. *Select waveform file:*
 - Push **SETUP**→**Waveform Sequence**, if necessary, to select a waveform file for CH1. Waveform Sequence toggles between the CH1 files (upper list) and the CH2 files (lower list).
 - Turn the general purpose knob to select the **PULSE.WFM** file.
 - Push **ENTER**.
3. *Turn on the AWG2021 CH1 output:* Push the **CH1** button so that the LED above the CH1 output connector is on.
4. *Check pulse response at 0.5 V amplitude:*
 - a. *Check rise time:* Check that the rise time of the waveform displayed on the oscilloscope from the 10% point to the 90% point is 4.2 ns or less.
 - b. *Check aberrations:* Check that the aberrations of the displayed waveform is within 0.45 div.
 - c. *Check flatness:* Check that the flatness of the displayed waveform is within 0.15 div. after 20 ns from the rising edge.
 - d. *Change the oscilloscope controls:*
 - Horizontal
 - Sweep 2 ns/div.
 - Trigger
 - Slope Negative
 - e. *Check fall time:* Check that the fall time of the displayed waveform from the 10% point to the 90% point is 4.2 ns or less.
5. *Check pulse response at 1 V amplitude:*
 - a. *Change the oscilloscope controls:*
 - Vertical CH1
 - CH1 scale 0.2 V/div.
 - Trigger
 - Slope Positive

b. *Change the AWG2021 controls:*

- Push **SETUP**→**Ampl** to change the amplitude for CH1.
- Press the numeric key **1**, and press the units key **V** to select an amplitude of 1 V.

c. *Repeat substeps 4a through e, checking to the following limits:*

Rise time	4.2 ns, maximum
Aberrations	0.4 div., maximum
Flatness	0.15 div., maximum
Fall time	4.2 ns, maximum

6. *Check pulse response for CH2 (Option 02):* If the AWG2021 has a second channel, repeat this *Pulse Response Check* procedure. Use the AWG2021 CH2 output and select the waveform and setting controls for CH2.

7. *End procedure:* Remove the connections.

SYNC Out and MARKER Out Amplitude Checks

These procedures check the amplitude of the SYNC Out and MARKER Out signals.

Electrical Characteristic Checked	Auxiliary Outputs, Sync, Marker 1, Marker 2, Amplitude, on page 1-10.
Equipment Required	One 50 Ω coaxial cable One oscilloscope
Prerequisites	The AWG2021 meets the prerequisites listed on page 4-7.

1. *Install test hookup and set test equipment controls:*

- a. *Hook up the oscilloscope:* Connect the AWG2021 CH1 SYNC Out connector through the coaxial cable to the CH1 vertical input connector on the oscilloscope (see Figure 4-16).

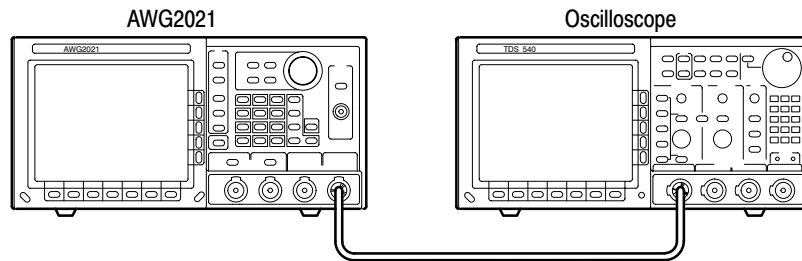

Figure 4-16: Initial Test Hookup

b. *Set oscilloscope controls:*

- Vertical CH1
- CH1 Coupling DC
- CH1 Scale 200 mV/div.
- CH1 Input Impedance 50 Ω
- Horizontal
- Sweep 50 ns/div.
- Trigger
- Source CH1
- Coupling DC
- Slope Positive
- Level 500 mV
- Mode Auto

2. *Set the AWG2021 controls and select the waveform file:*
 - a. *Initialize AWG2021 controls:* Push **UTILITY**→**Misc**→**Config...**→**Reset to Factory**→**O.K.**
 - b. *Select waveform file:*
 - Push **SETUP**→**Waveform Sequence**, if necessary, to select a waveform file for CH1. Waveform Sequence toggles between the CH1 files (upper list) and the CH2 files (lower list).
 - Turn the general purpose knob to highlight the **SYNC_MRK.WFM** file.
 - Push **ENTER**.
3. *Check front-panel SYNC Out and MARKER 1 Out amplitude:*
 - a. *Check SYNC Out pulse amplitude:* Check that the pulse amplitude of the waveform displayed on the oscilloscope is 1.2 V_{p-p} or greater.
 - b. *Check CH1 MARKER 1 Out pulse amplitude:*
 - Move the coaxial cable from the AWG2021 CH1 SYNC Out connector to the CH1 MARKER 1 connector.
 - Change the oscilloscope sweep to 5 μs/div.
 - Check that the pulse amplitude of the displayed waveform is from 2.250 V_{p-p} to 2.625 V_{p-p}.
4. *Check rear-panel CH1 MARKER 2 OUT pulse amplitude:*
 - a. Remove the coaxial cable from the AWG2021 front-panel CH1 MARKER 1 connector and connect it through the SMA-BNC adapter to the rear-panel CH1 MARKER 2 OUT connector.
 - b. Check that the pulse amplitude of the displayed waveform is from 2.250 V_{p-p} to 2.625 V_{p-p}.
5. *Check Option 02:* If the AWG2021 has a second channel, repeat this entire test. Select the AWG2021 waveform and set controls for CH2, and check the following parameters:
 - Rear-panel CH2 SYNC Out pulse amplitude (see step 3a)
 - Rear-panel CH2 MARKER 1 pulse amplitude (see step 3b)
 - Rear-panel CH2 MARKER 2 pulse amplitude (see step 4)
6. *End procedure:* Disconnect the oscilloscope.

External Trigger Level Accuracy Check

This procedure checks the external trigger level accuracy of the AWG2021.

Electrical Characteristic Checked	Auxiliary Inputs, Trigger, Accuracy, on page 1-12.
Equipment Required	Two 50 Ω coaxial cables One function generator One oscilloscope
Prerequisites	The AWG2021 meets the prerequisites listed on page 4-7.

1. *Install test hookup and set test equipment controls:*

- a. *Hook up oscilloscope:* Connect the AWG2021 CH1 output through a coaxial cable to the oscilloscope CH1 vertical input.
- b. *Hook up function generator:* Connect the AWG2021 TRIGGER INPUT through a coaxial cable to the function generator output (see Figure 4-17).

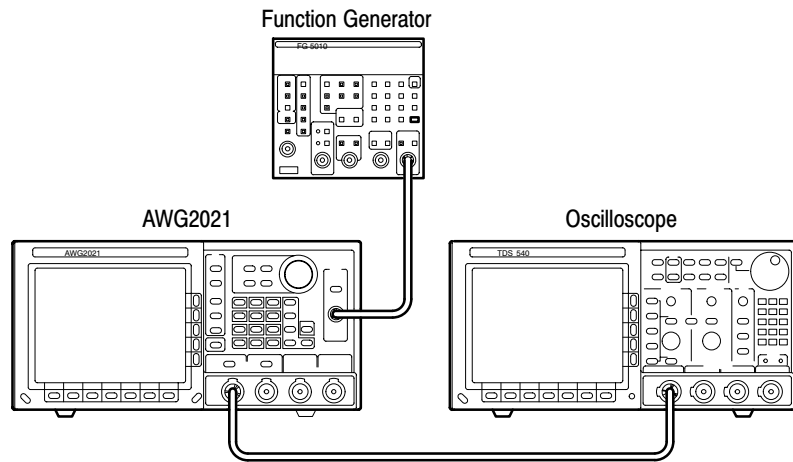

Figure 4-17: External Trigger Level Accuracy Initial Test Hookup

c. *Set oscilloscope controls:*

- Vertical CH1
- CH1 Coupling DC
- CH1 Scale 0.2 V/div.
- CH1 Input Impedance 50 Ω

Horizontal
 Sweep 50 μ s/div.
 Trigger
 Source CH1
 Coupling DC
 Slope Positive
 Level 0 V
 Mode Auto

d. *Set function generator controls:*

Function Square
 Mode Continuous
 Parameter
 Frequency 1 kHz
 Amplitude 0 V
 Offset 0.6 V
 Output Off

2. *Select the AWG2021 waveform file and set AWG2021 controls:*

a. *Initialize AWG2021 controls:* Push **UTILITY**→**Misc**→**Config...**→**Reset to Factory**→**O.K.**

b. *Modify AWG2021 default settings:*

- Push **MODE**→**Gated**→**Polarity** to highlight **Positive**.
- Select **Level** from the side menu, and turn the general purpose knob to select 1 V. (You can also use the numeric and units keys to select 1 V; then push **ENTER**.)
- Select **Impedance** from the side menu to highlight **1 M Ω** .

c. *Select waveform file:*

- Push **SETUP**→**Waveform Sequence**, if necessary, to select a waveform file for CH1. Waveform Sequence toggles between the CH1 files (upper list) and the CH2 files (lower list).
- Turn the general purpose knob to highlight the **TRG_IN.WFM** file.
- Push **ENTER**.

3. *Turn on the AWG2021 CH1 output:* Push the **CH1** button so that the LED above the CH1 output connector is on.

4. *Check external trigger high level:*
 - a. *Adjust oscilloscope controls:* Press and hold the AWG2021 **MANUAL TRIGGER** button and adjust the oscilloscope vertical and horizontal position to display the waveform from the AWG2021. Release the **MANUAL TRIGGER** button.
 - b. *Enable function generator output:* Turn on the function generator output.
 - c. *Check external trigger level accuracy:*
 - Gradually increase the function generator offset level until a waveform is displayed on the oscilloscope.
 - Check that the function generator offset level is from +0.85 to +1.15 V, when the waveform is first displayed.

5. *Check external trigger low level:*
 - a. *Change the function generator controls:*

Parameter
Offset -0.6 V
 - b. *Change the AWG2021 controls:*
 - Push **MODE**→**Polarity** to highlight **Negative**.
 - Select **Level** from the side menu, and turn the general purpose knob to select -1 V. (You can also use the numeric and units keys to select -1 V; then push **ENTER**.)
 - c. *Check external trigger level accuracy:*
 - Gradually decrease the function generator offset level until a waveform is displayed on the oscilloscope.
 - Check that the function generator offset level is from -1.15 V to -0.85 V, when the waveform is first displayed.

6. *End procedure:* Turn off the function generator output and disconnect the function generator.

External CLOCK IN Check

This procedure checks the AWG2021 response to an external CLOCK IN signal.

Electrical Characteristic Checked	Auxiliary Inputs, Clock, Threshold level, on page 1-12.
Equipment Required	Two 50 Ω coaxial cables One function generator One oscilloscope
Prerequisites	The AWG2021 meets the prerequisites listed on page 4-7.

1. Install test hookup and set test equipment controls:

- a. *Hook up oscilloscope:* Connect the AWG2021 CH1 output through a coaxial cable to the oscilloscope CH1 vertical input.
- b. *Hook up function generator:* Connect the AWG2021 rear-panel CLOCK IN through a coaxial cable and SMA-BNC adapter to the function generator output (see Figure 4-18).

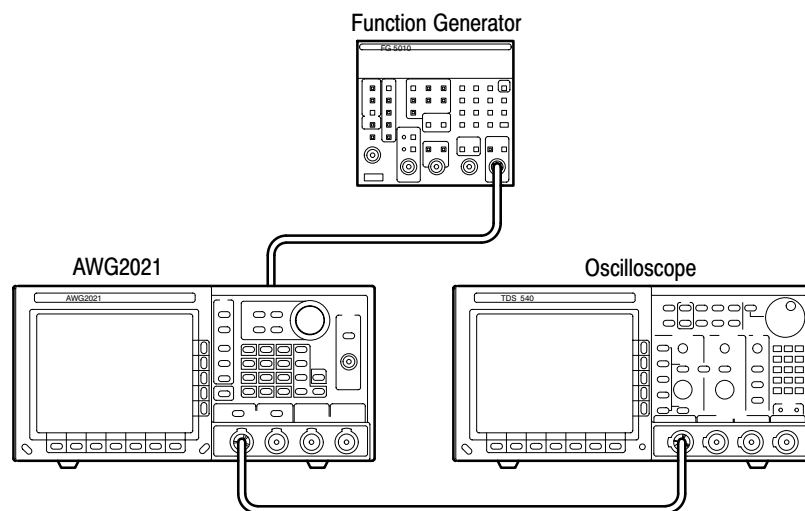

Figure 4-18: External CLOCK IN Initial Test Hookup

c. *Set oscilloscope controls:*

Vertical CH1
Coupling DC
Scale 0.2 V/div.
Input Impedance 50 Ω
Horizontal
Sweep 500 μ s/div.
Trigger
Source CH1
Coupling DC
Slope Positive
Level 0 mV
Mode Auto

d. *Set function generator controls:*

Function Square
Mode Continuous
Parameter
Frequency 1 MHz
Amplitude 1.6 V
Offset 0.6 V
Output Off

2. *Select the AWG2021 waveform file and set AWG2021 controls:*

a. *Initialize AWG2021 controls:* Push **UTILITY**→**Misc**→**Config...**→**Reset to Factory**→**O.K.**

b. *Select waveform file:*

- Push **SETUP**→**Waveform Sequence**, if necessary, to select a waveform file for CH1. Waveform Sequence toggles between the CH1 files (upper list) and the CH2 files (lower list).
- Turn the general purpose knob to highlight the **EXT_CLK.WFM** file.
- Push **ENTER**.

3. *Turn on the AWG2021 CH1 output:* Push the **CH1** button so that the LED above the CH1 output connector is on.

4. *Check the external CLOCK IN threshold level:*

- a. *Enable function generator output:* Turn on function generator output.
- b. *Check the level:* Check that the waveform displayed on the oscilloscope has an amplitude of 5 divisions and a stable display of 5 cycles.

5. *Turn off equipment output and disconnect test hookup:*

- a. *Disable function generator output:* Turn off function generator output.
- b. *Remove connections:* Disconnect all connections to the AWG2021.

ECL Digital Data Out Check (Option 03)

This procedure checks the AWG2021 ECL digital data output at the rear panel.

NOTE. This check requires that the AWG2021 has Option 03 installed.

Electrical Characteristic Checked	Auxiliary Outputs, ECL Digital Data Out, Level, on page 1–11.
Equipment Required	Test leads One ECL digital data out cable One power supply One termination board One oscilloscope
Prerequisites	The AWG2021 meets the prerequisites listed on page 4–7. Option 03 (ECL digital data output) must be installed in the AWG2021.

1. *Install test hookup and set test equipment controls:*

- a.** *Hook up termination board:* Connect the AWG2021 rear ECL digital data output through a digital data output cable to the termination board (see Figure 4–19).
- b.** *Hook up power supply:* Connect the power supply output through the test leads to the GND TP100 and –2VD TP120 terminals on the termination board.
- c.** *Hook up oscilloscope:*
 - Connect the oscilloscope probe to the CH1 vertical input.
 - Connect the probe ground-clip to the GND TP200 terminal on the termination board.

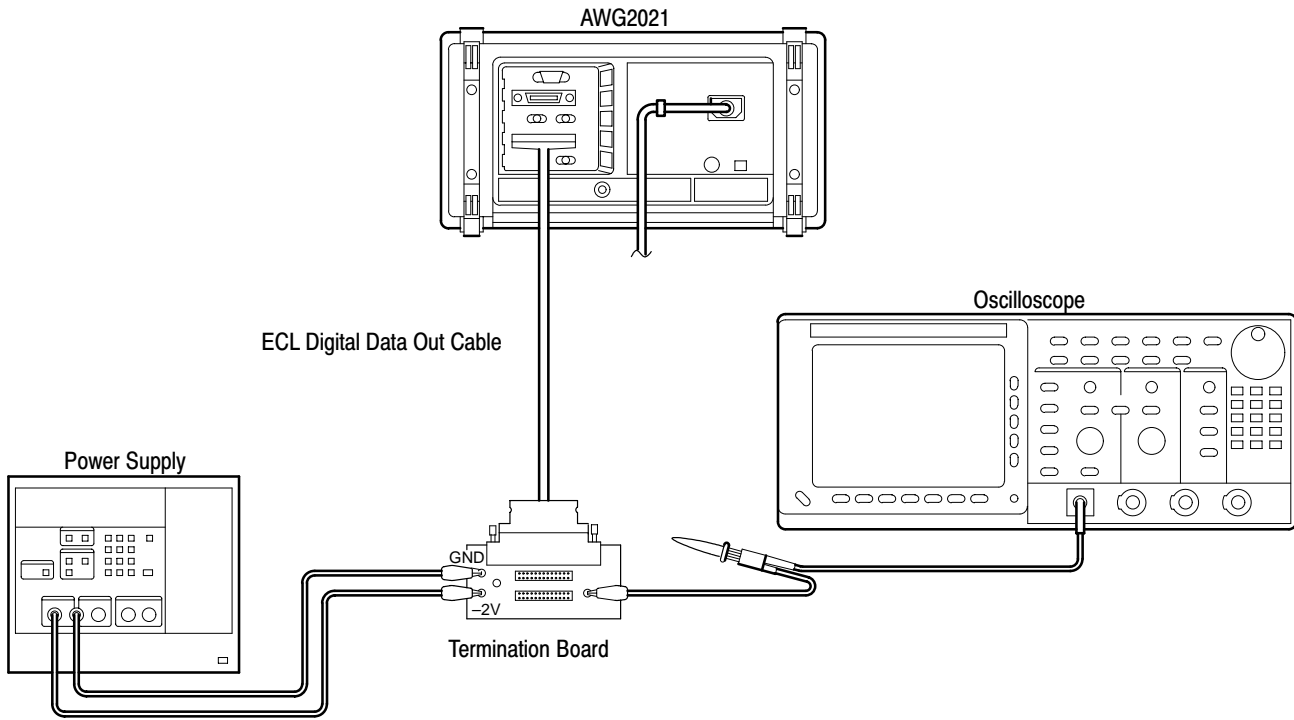

Figure 4-19: ECL Digital Data Out Initial Test Hookup

d. Set oscilloscope controls:

Vertical CH1
 Scale 0.1 V/div.
 Input Impedance 1 M Ω
 Horizontal
 Sweep Adjust as needed
 Trigger
 Mode Auto

e. Set power supply controls:

Parameter
 Supply select Negative
 Voltage 2

2. Create the AWG2021 waveform file, select waveform file, and set AWG2021 controls:

a. Initialize AWG2021 controls: Push **UTILITY→**Misc**→**Config...**→**Reset to Factory**→**O.K.****

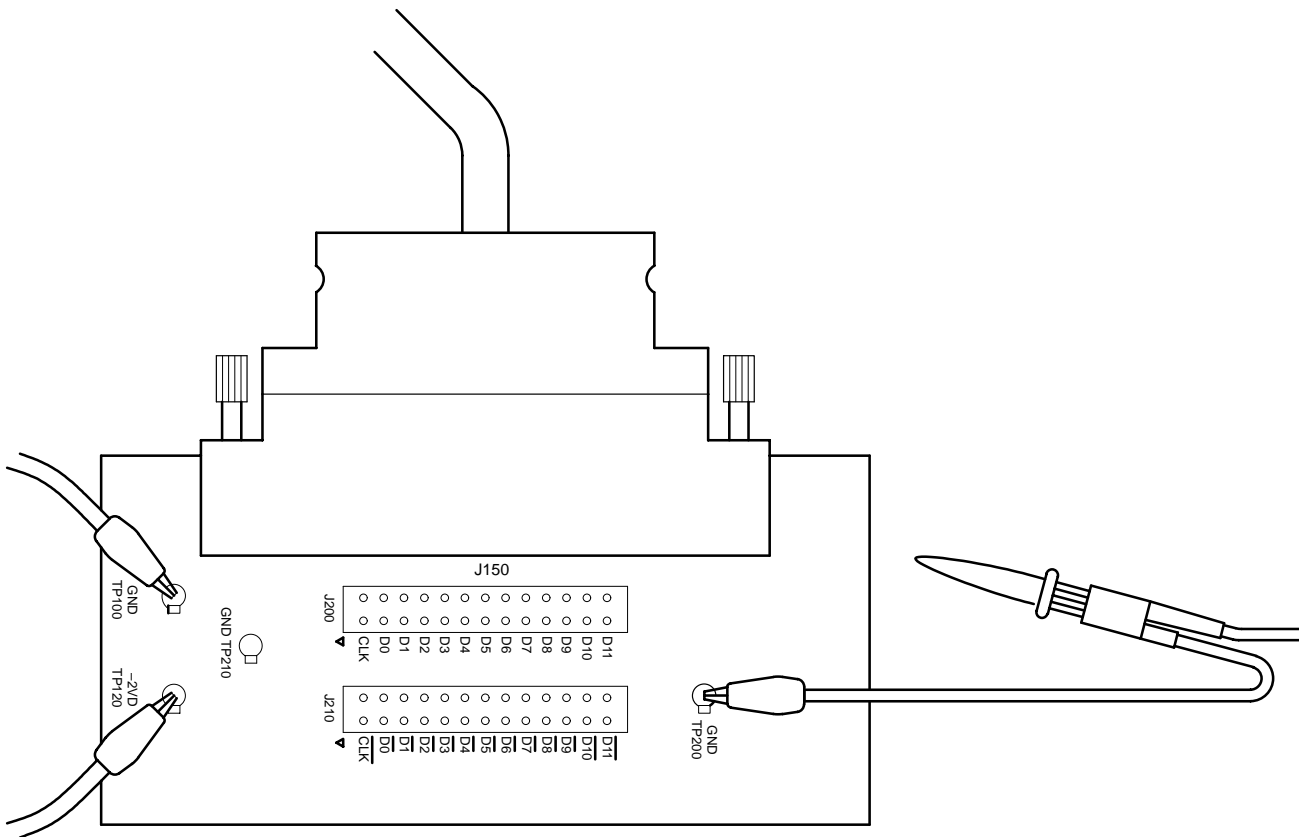

Figure 4-20: Output Pins on the Termination Board

5. *Turn off equipment output and disconnect test hookup:*
 - a. *Disable power supply output:* Turn off power supply output.
 - b. *Remove connections:* Disconnect all connections to the AWG2021.

TTL DIGITAL DATA OUT Check (Option 04)

This procedure checks the AWG2021 TTL DIGITAL DATA OUT at the rear panel.

NOTE. This check requires that the AWG2021 has Option 04 installed.

Electrical Characteristic Checked	Auxiliary Output, TTL DIGITAL DATA OUT, Level, on page 1-11.
Equipment Required	One TTL Digital data out cable One 2 × 13 header One probe One oscilloscope
Prerequisites	The AWG2021 meets the prerequisites listed on page 4-7. Option 04 (TTL digital data output) must be installed in the AWG2021.

1. *Install test hookup and set test equipment controls:*
 - a. *Hook up termination board:* Connect a digital data output cable to the AWG2021 rear-pane **CH1 DIGITAL DATA OUT** output (see Figure 4-21).

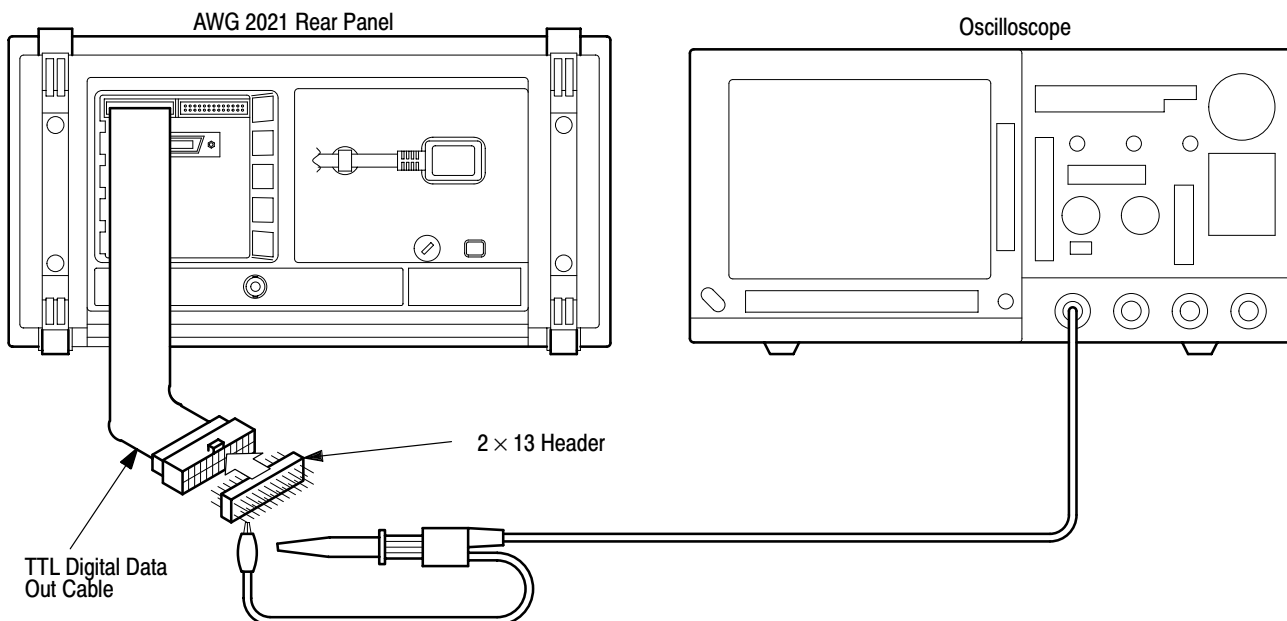

Figure 4-21: TTL Digital Data Out Initial Test Hookup

- b. *Hook up oscilloscope:*
 - Connect the oscilloscope probe to the CH1 vertical input.
 - Connect the probe ground-clip to the GND pin of 2 × 13 header.

c. *Set oscilloscope controls:*

Vertical CH1
 Scale 1 V/div.
 Input Impedance 1 MΩ
 Horizontal
 Sweep Adjust as needed
 Trigger
 Mode Auto

2. *Create the AWG2021 waveform file, select waveform file, and set AWG2021 controls:*

- a. *Initialize AWG2021 controls:* Push **UTILITY**→**Misc**→**Config...**→**Reset to Factory**→**O.K.**

- b. *Select waveform file:*

- Push **SETUP**→**Waveform Sequence**, if necessary, to select a waveform file for CH1. If Option 02 is installed (Option 02 adds the CH2 output channel), **Waveform Sequence** toggles between the CH1 files (upper list) and the CH2 files (lower list).
- Turn the general purpose knob to highlight the **DIGI_OUT.WFM** file.
- Push **ENTER** to select the file.

- c. *Set AWG2021 controls:*

- Push **MODE**→**Cont**

3. *Check the CH1 digital data output signals:*

- a. *Check the signal levels:* Contact the oscilloscope probe to the pins on 2 × 13 header (see Figure 4–22). Check that the oscilloscope display shows these signals:

- Data signals D0-D11 and CLK (Clock) are TTL level output.
- All other pins are ground.

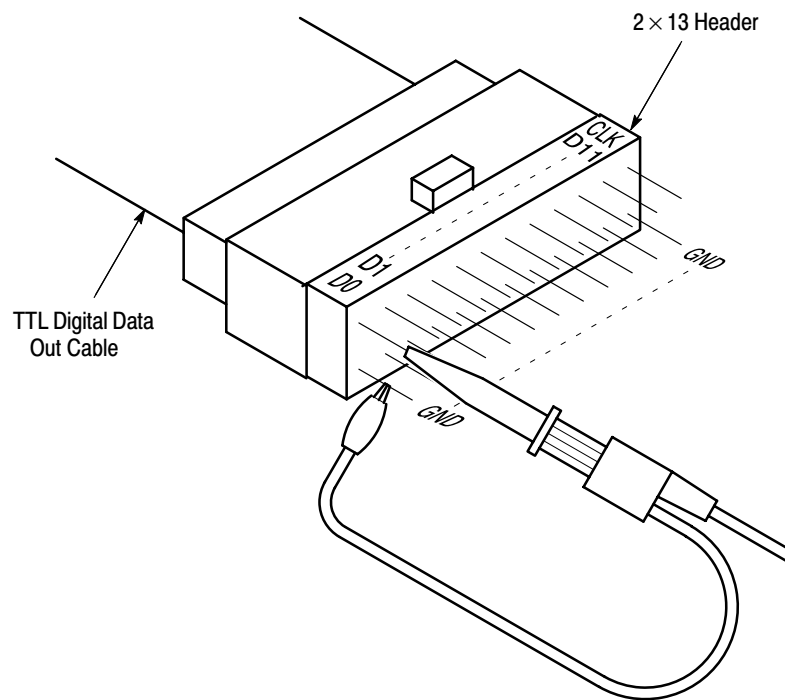

Figure 4-22: Output Pins on the TTL Digital Data Out Cable

4. *If Option 02 is installed, check the CH2 digital data output signals:*
 - a. *Change connection:* Change the connection for the TTL digital data out cable from CH1 DIGITAL DATA OUT connector to CH2 DIGITAL DATA OUT connector.
 - b. Repeat steps 2 and 3 to check the CH2 digital data output signals.
5. *Turn off equipment output and disconnect test hookup:*
 - a. *Disable power supply output:* Turn off power supply output.
 - b. *Remove connections:* Disconnect all connections to the AWG2021.

Floating Point Processor Check (Option 09)

This procedure checks the AWG2021 floating point processor.

NOTE. *This check requires that the AWG2021 has Option 09 installed.*

Equipment Required	None
Prerequisites	The AWG2021 meets the prerequisites listed on page 4-7. Option 09 (floating point processor) must be installed in the AWG2021.

1. *Run the AWG2021 internal diagnostics to check that floating point processor test passes:* Push the AWG2021 **ON/STBY** switch two times so that the AWG2021 runs the power-on diagnostics.
2. *Check the FPP test results:* When the AWG2021 finishes the FPP test, check that the test result is Pass.

This completes the performance tests for the AWG2021.

Adjustment Procedures

Adjustment Procedures

This section contains information needed to manually adjust the AWG2021 Arbitrary Waveform Generator.

The *Adjustment Procedures* section consists of two subsections:

- *Before Adjustments*. Provides general information about adjusting the AWG2021 and the Performance Check/Adjustment disk files.
- *Adjustments*. Procedures for manually adjusting the AWG2021.

Use the *Adjustments* subsection to return the AWG2021 to conformance with performance specified in section 1, *Specifications*. This procedure is not required to verify AWG2021 performance; for performance verification procedures see section 4, *Performance Verification*.

Use the following guidelines to determine when to do these adjustments:

- *Adjustment Interval*. Generally, these adjustments should be done every 12 months.
- *Adjustment After Repair*. After the removal and replacement of a module due to electrical failure, do the adjustment procedures in this section.

Requirements for Performance

Before doing the adjustments, note the following requirements.

- **Personnel**. Only trained service technicians should perform these procedures.
- **Access to Adjustments**. The cabinet must be removed and additional ventilation must be provided when making the adjustments in this procedure. See *Adjustment Instructions* in this subsection for detailed information.
- **Warmup Period**. This AWG2021 requires a 20 minute warmup period in a 20° C to 30° C environment before it is adjusted. Adjustments done before the operating temperature has stabilized may cause errors in performance.
- **Internal Calibration**. Calibrate the AWG2021 using the internal calibration routine. See the subsection, *Self Tests*, in section 4 for instructions.
- **Performance Check/Adjustment Files**. These adjustment procedures require loading a file from the Performance Check/Adjustment disk included with this manual. See *Adjustment Instructions* in this subsection for information about this file.
- **Test Equipment**. Table 5–1 lists all test equipment required to adjust the AWG2021.

Equipment Required

Table 5–1 lists the test equipment required to adjust the AWG2021.

Table 5–1: Test Equipment

Item Description	Minimum Requirements	Example	Purpose
BNC cable	Impedance: 50 Ω Connectors: BNC Length: 43 inches	Tektronix Part 012-0057-XX	Signal interconnection
PELTOLA cable with BNC connector*	Must use example equipment	Tektronix Part 131-1315-XX	Signal interconnection
Test oscilloscope	Bandwidth: >250 MHz	Tektronix TDS500 Series Digitizing Oscilloscope or 2400 Series Digitizing Oscilloscope	Used to check output signals
Digital multimeter	DC volts range: 0.05 V to 5 V Accuracy: $\pm 0.1\%$	Fluke 8842A Digital Multimeter	Used to measure voltage
Fan			Used to cool the AWG2021

* The PELTOLA cable with BNC connector is included in the maintenance kit (Tektronix Part 067-1396-01).

Before Adjustments

The following instructions describe preparing the AWG2021 for adjustment, loading the adjustment file required for these procedures, and making adjustments.

Providing Access



CAUTION. To avoid damaging the eject button, make sure a floppy disk is NOT in the floppy disk drive before removing the cabinet.

Before doing the adjustments, remove the AWG2021 rear cover and cabinet. See section 6, *Maintenance*, for instructions on removing the cabinet and replacing it after adjustment is done.

Cooling



CAUTION. To prevent damage to the AWG2021 due to over-heating, do not do the adjustment procedures without providing additional cooling, as described below.

With the rear cover and cabinet removed, the AWG2021 assembly does not cool properly while power is applied. A separate fan is needed to prevent heat build-up. Place the fan so it blows air INTO the AWG2021 side near the floppy-disk drive, as shown in Figure 5-1.

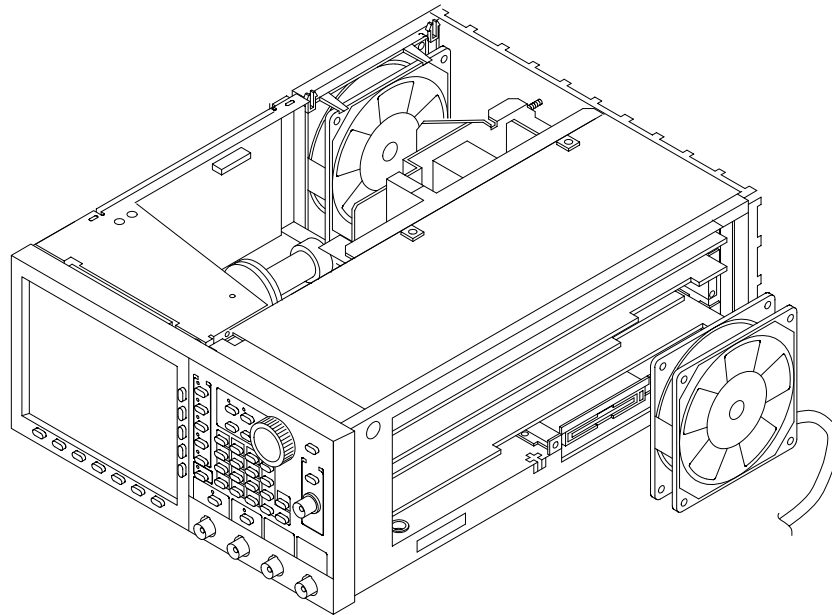

Figure 5-1: Cooling the AWG2021 During Adjustment Procedures

Performance Check/Adjustment Files

Table 5–2 lists the waveform file on the Performance Check/Adjustment disk that is required to do the adjustments. The table lists the front-panel settings that the file sets up and the adjustment procedures that use the file.

For instructions on loading files, see *Loading Files* on page 2–14. After loading the files, press the button on the floppy disk drive and remove the floppy disk.

Table 5–2: File List for Performance Check/Adjustment Disk

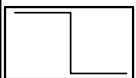
No.	File Name	EDIT Menu		SETUP Menu					Usage
		Wfm Shape	Wfm Point	Clock	Operation	Filter	Ampl	Offset	
1	HF_LF.WFM		1000	100 MHz	Normal	Through	0.5 V	0 V	All

NOTE. The files on the Performance Check/Adjustment disk are locked (the files names are displayed with *), so the data in these files cannot be changed unless the lock is opened. The file data includes not only waveform data, but also output parameters.

When you select a file with the Waveform Sequence item, the AWG2021 output parameters change to those specified in the file, and the waveform output reflects waveform data in the file. After selecting a file, do not change an output parameter with the SETUP menu unless a procedure instructs you to do so. During the procedures, if you are unsure that the AWG2021 settings still match the file's settings, select the waveform again using the Waveform Sequence item on the SETUP menu.

Adjustments

This subsection describes how to adjust internal circuits of the AWG2021. Before doing these adjustments, read *Before Adjustments* on page 5-2.

X5 Amplifier HF Compensation

Equipment Required	One 50 Ω coaxial cable
	One oscilloscope
Prerequisites	The AWG2021 must meet the requirements for performance listed on page 5-1.

1. *Install the test hookup and set test equipment controls:*

- a. *Hook up the oscilloscope:* Connect the AWG2021 CH1 output connector through the coaxial cable to the CH1 vertical input connector on the oscilloscope (see Figure 5-2).

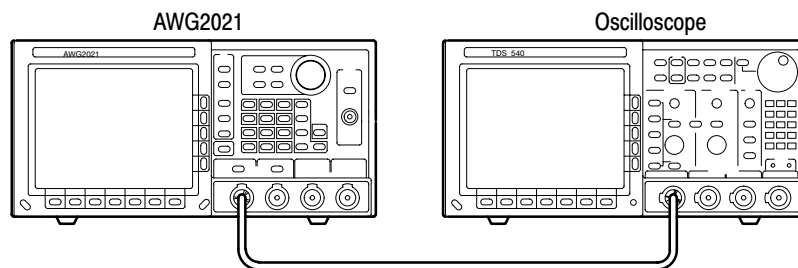

Figure 5-2: Hookup for X5 Amplifier HF Compensation

b. *Set oscilloscope controls:*

Vertical	CH1
CH1 coupling	DC
CH1 scale	0.1 V/div.
CH1 input impedance	50 Ω
Horizontal	
Sweep	5 ns/div.
Trigger	
Source	CH1
Coupling	DC
Slope	Positive
Level	0 V
Mode	Auto

2. *Set the AWG2021 controls and select the waveform file:*
 - a. *Initialize AWG2021 controls:* Push **UTILITY**→**Misc**→**Config...**→**Reset to Factory**→**O.K.**
 - b. *Select the waveform file:*
 - Push **SETUP**→**Waveform Sequence**, if necessary, to select a waveform file for CH1. Waveform Sequence toggles between the CH1 files (upper list) and the CH2 files (lower list).
 - Turn the general purpose knob to highlight the HF_LF.WFM file.
 - Push **ENTER** to select the file.
3. *Enable AWG2021 output:* Push the CH1 output **ON/OFF** button.
4. *Adjust CH1 compensation:*
 - a. *Adjust oscilloscope display:* Adjust the horizontal and vertical position to center the waveform on the display.
 - b. *Change AWG2021 amplitude:*
 - Push the **SETUP**→**Ampl.**
 - Press the numeric . (decimal point) key, the numeric **5**, **0**, **1** keys, and units **V** key to select 0.501 V.
 - c. *Adjustment:* Adjust C201 on the Analog board (A3) for best flatness at 0.500 V. See Figure 5–3 for adjustment location.
5. *If Option 02 is installed, adjust CH2 compensation:*
 - a. Move the cable from the AWG2021 CH1 output to the CH2 output.
 - b. Repeat steps 2 through 4, selecting the waveform and setting AWG2021 controls for CH2.
 - c. Adjust C201 on the Analog board (A23) for best flatness at 0.500 V. See Figure 5–3 for adjustment location.
6. *End procedure:* Disconnect the oscilloscope.

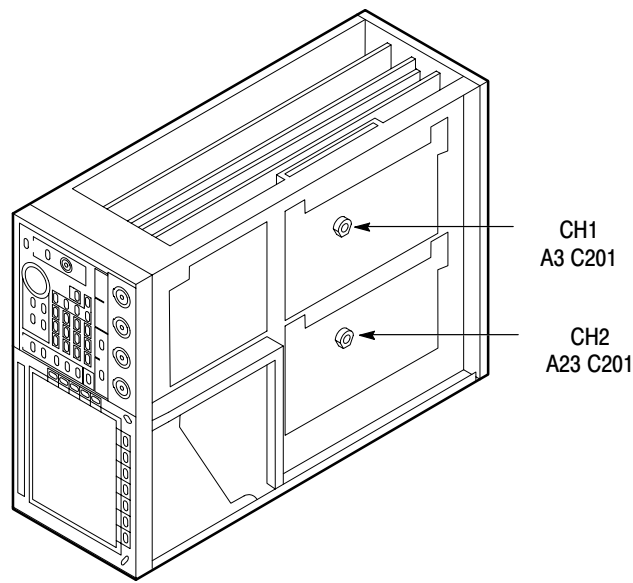

Figure 5-3: C201 Locations for CH1 and CH2

Attenuator LF Compensation

Equipment Required	Two 50 Ω coaxial cables One PELTOLA cable One oscilloscope
Prerequisites	The AWG2021 must meet the requirements for performance listed on page 5-1.

1. *Install the test hookup and set test equipment controls:*
 - a. *Hook up the AWG2021:* Connect the AWG2021 CH1 output connector through the coaxial cable to the AWG2021 TRIGGER INPUT.
 - b. *Hook up the oscilloscope:*
 - Disconnect the J310 cable from the A4 Power board. See Figure 5-4.
 - Connect the PELTOLA cable with BNC connector to J301. Figure 5-5 shows the cable and BNC details.
 - Connect the other end of the PELTOLA cable through a coaxial cable to the oscilloscope CH1 vertical input.

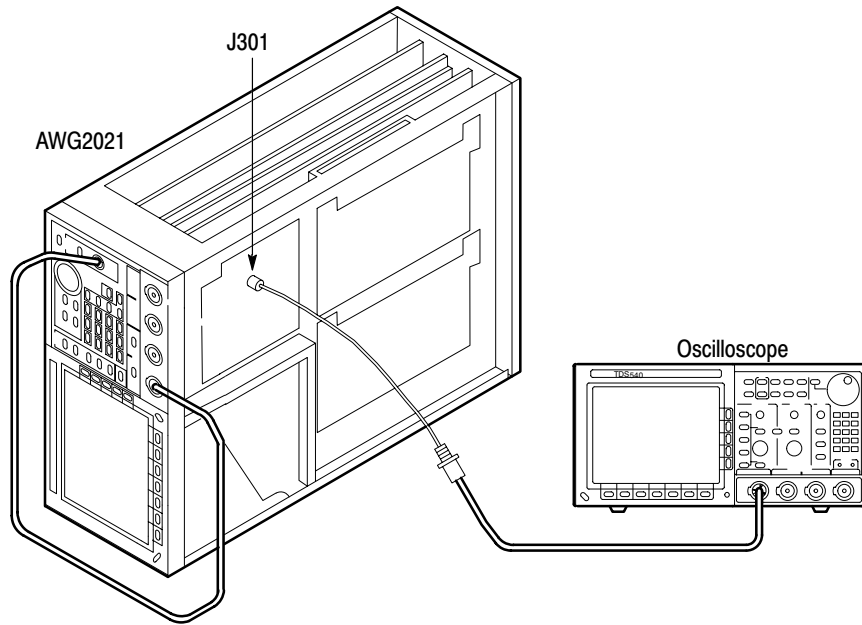

Figure 5-4: Hookup for Attenuator LF Compensation

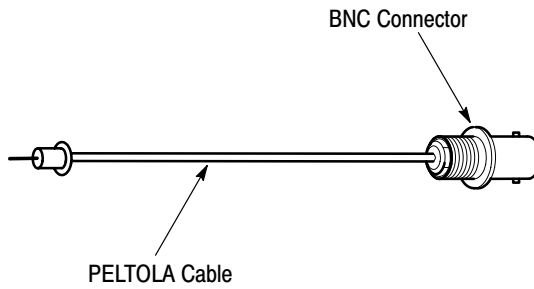

Figure 5-5: PELTOLA Cable with BNC

c. *Set oscilloscope controls:*

- Vertical CH1
- CH1 coupling DC
- CH1 scale 50 mV/div.
- CH1 input impedance 50 Ω
- Horizontal
- Sweep 2 μs/div.
- Trigger
- Source CH1
- Coupling DC
- Slope Positive
- Level 0 V
- Mode Auto

2. *Set AWG2021 controls and select the waveform file:*
 - a. *Initialize AWG2021 controls:* Push **UTILITY**→**Misc**→**Config...**→**Reset to Factory**→**O.K.**
 - b. *Select the waveform file:*
 - Push **SETUP**→**Waveform Sequence**, if necessary, to select a waveform file for CH1. Waveform Sequence toggles between the CH1 files (upper list) and the CH2 files (lower list).
 - Turn the general purpose knob to highlight the HF_LF.WFM file.
 - Push **ENTER**.
3. *Enable AWG2021 output:* Push the CH1 output **ON/OFF** button.
4. *Adjust compensation:*
 - a. *Adjust oscilloscope display:* Adjust the horizontal and vertical position to display the rising edge of the waveform.
 - b. *Adjustment:* Adjust C301 on the Power board (A4) so the tip of the waveform is flat. See Figure 5–6 for adjustment location.

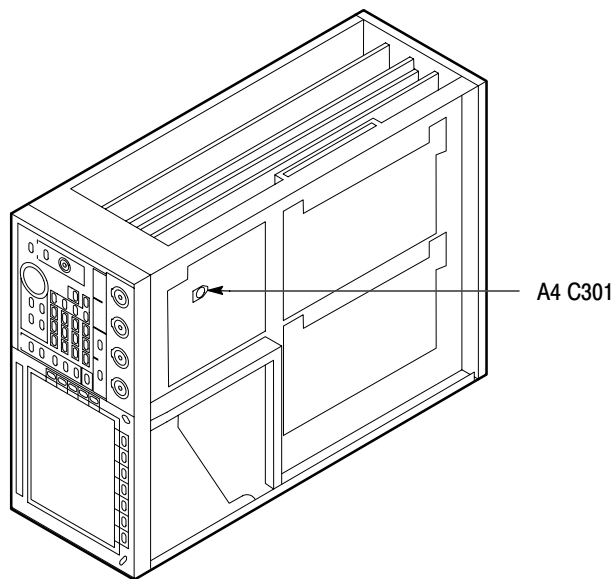

Figure 5–6: C301 Location

5. *End procedure:*

- Disconnect the coaxial cable between the AWG2021 CH1 and TRIGGER INPUT.
- Disconnect the PELTOLA cable and coaxial cable between the AWG2021 A4 Power board and oscilloscope.
- Install cable J310 on the A4 Power board.

End Adjustment Procedures

This is the end of the *Adjustments*. Follow these steps to restore the AWG2021 to service:

1. *Initialize AWG2021 controls:* Push **UTILITY**→**Misc**→**Config...**→**Reset to Factory**→**O.K.**
2. *Equipment power-down:*
 - Turn off oscilloscope power.
 - Push the **OFF/STBY** button on the AWG2021 to toggle off operating power.
 - Push the **PRINCIPAL POWER** switch on the back of the AWG2021 to turn off main power.
 - Unplug the AWG2021 power cord from the line source.
3. *Eject floppy disk:* Remove the Performance Check/Adjustment disk from AWG2021 floppy disk drive.
4. Install the AWG2021 cabinet and rear panel. See section 6, *Maintenance*, for instructions on replacing the cabinet.

Maintenance

Maintenance

This section contains the information needed to do periodic and corrective maintenance on the AWG2021 Arbitrary Waveform Generator. Specifically, the following subsections are included:

- *Preparation.* This subsection includes this introduction plus general information on preventing damage to internal modules when doing maintenance. See below.
- *Inspection and Cleaning.* Information and procedures for inspecting the AWG2021 and cleaning its external and internal modules. See page 6–4.
- *Removal and Installation Procedures.* Procedures for removing defective modules and replacing new or repaired modules. See page 6–9.
- *Troubleshooting.* Information for isolating failed modules. Included are instructions for operating the AWG2021 internal diagnostic routines and troubleshooting flowcharts for fault isolation. Most of the flowcharts make use of the internal diagnostic routines to speed fault isolation to a module. See page 6–53.

Preparation

Before doing any of the procedures in the *Maintenance* section, note the following:

- Only trained service technicians should perform these procedures.
- Read the *General Safety Summary* and the *Service Safety Summary*, beginning on page ix near the beginning of this manual.
- Read the *Strategy for Servicing* on page xv near the beginning of this manual.
- Read section 2, *Operating Information*, before servicing the AWG2021.

Preventing ESD



CAUTION. *Static discharge can damage any semiconductor component in the AWG2021.*

Precautions. When performing service which requires internal access to the AWG2021, follow these precautions to avoid damaging internal modules and their components due to electrostatic discharge (ESD).

1. Minimize handling of static-sensitive modules.
2. Transport and store static-sensitive modules in their static-protected containers or on a metal rail. Label any package that contains static-sensitive modules.
3. Discharge the static voltage from your body by wearing a grounded antistatic wrist strap while handling these modules. Do service of static-sensitive modules only at a static-free work station.
4. Do not remove the AWG2021 cabinet unless you have met precaution number 3, above. Consider all internal modules static-sensitive.
5. Do not allow anything capable of generating or holding a static charge on the work station surface.
6. Handle circuit boards by the edges when possible.
7. Do not slide the modules over any surface.
8. Avoid handling modules in areas that have a floor or work-surface covering capable of generating a static charge.
9. Do not use high-velocity compressed air when cleaning dust from modules.

Susceptibility to ESD. Table 6–1 lists the relative susceptibility of various classes of semiconductors. Static voltages of 1 kV to 30 kV are common in unprotected environments.

Table 6-1: Relative Susceptibility to Static-Discharge Damage

Semiconductor Classes	Relative Susceptibility Levels¹
MOS or CMOS microcircuits or discrete circuits, or linear microcircuits with MOS inputs (most sensitive)	1
ECL	2
Schottky signal diodes	3
Schottky TTL	4
High-frequency bipolar transistors	5
JFET	6
Linear microcircuits	7
Low-power Schottky TTL	8
TTL (least sensitive)	9

¹ **Voltage equivalent for levels (voltage discharged from a 100 pF capacitor through resistance of 100 ohms):**

1 = 100 to 500 V	6 = 600 to 800 V
2 = 200 to 500 V	7 = 400 to 1000 V (est.)
3 = 250 V	8 = 900 V
4 = 500 V	9 = 1200 V
5 = 400 to 600 V	

Inspection and Cleaning

This subsection describes how to determine whether the AWG2021 needs cleaning, and how to do the cleaning. Inspection and cleaning are preventive maintenance procedures. When done regularly, preventive maintenance may prevent AWG2021 malfunction and enhance reliability.

Preventive maintenance consists of visually inspecting and cleaning the AWG2021, and using general care when operating it.

How often to do maintenance depends on the severity of the environment in which the AWG2021 operates. A proper time to perform preventive maintenance is just before doing the internal adjustments described in section 5, *Adjustment Procedures*.

General Care

The cabinet helps keep dust out of the AWG2021 and is a major component of the instrument cooling system. The cabinet should normally be in place when operating the AWG2021. The AWG2021 front cover (optional accessory) protects the front panel and display from dust and damage. Install it when storing or transporting the instrument.

Inspection and Cleaning Procedures

Inspect and clean the AWG2021 as operating conditions require. The collection of dirt on components inside can cause them to overheat and break down. (Dirt acts as an insulating blanket, preventing efficient heat dissipation.) Dirt also provides an electrical conduction path that can cause an instrument failure, especially under high-humidity conditions.



WARNING. To avoid personal injury or death due to electric shock, unplug the power cord from the line voltage source before cleaning the AWG2021.



CAUTION. To prevent damaging the plastics used in the AWG2021, do not use chemical cleaning agents. Use only deionized water when cleaning the menu buttons or front-panel buttons. Use a 75% isopropyl alcohol solution as a cleaner, and rinse with deionized water. Before using any other type of cleaner, consult your Tektronix Service Center or representative.

To prevent damaging AWG2021 components, do not use high-pressure compressed air when cleaning dust from the interior of the AWG2021. (High pressure air can cause electrostatic discharge.) Instead, use low pressure compressed air (about 9 psi).

Inspection — Exterior. Inspect the outside of the AWG2021 for damage, wear, and missing parts, using Table 6–2 as a guide. If the AWG2021 appears to have been dropped or otherwise abused, check it thoroughly to verify correct operation and performance. Repair any defects that may cause personal injury or lead to further damage to the AWG2021.

Table 6–2: External Inspection Check List

Item	Inspect For	Repair Action
Cabinet, front panel, and cover	Cracks, scratches, deformations, damaged hardware or gaskets	Replace defective module.
Front-panel knobs	Missing, damaged, or loose knobs	Repair or replace missing or defective knobs.
Connectors	Broken shells, cracked insulation, and deformed contacts; dirt in connectors	Replace defective modules. Clear or wash out dirt.
Carrying handle, cabinet, feet	Correct operation	Replace defective module.
Accessories	Missing items or parts of items, bent pins, broken or frayed cables, and damaged connectors	Replace damaged or missing items, frayed cables, and defective modules.

Cleaning Procedure — Exterior.



WARNING. To avoid potential electric shock hazard or damage to the AWG2021 circuits, do not allow any moisture inside the AWG2021 during external cleaning; use only enough liquid to dampen the cloth or applicator.

1. Remove loose dust on the outside of the AWG2021 with a lint free cloth.
2. Remove remaining dirt with a lint free cloth dampened in a general purpose detergent-and-water solution. Do not use abrasive cleaners.
3. Clean the light filter protecting the monitor screen with a lint-free cloth dampened with either isopropyl alcohol or, preferably, a gentle, general purpose detergent-and-water solution.

Inspection — Interior. To access the inside of the AWG2021 for inspection and cleaning, refer to the *Removal and Installation Procedures* in this section.

Inspect the internal portions of the AWG2021 for damage and wear using Table 6–3 as a guide. Repair any defects immediately.



CAUTION. To prevent damage from electrical arcing, ensure that circuit boards and components are dry before applying power to the AWG2021.

Table 6-3: Internal Inspection Check List

Item	Inspect For	Repair Action
Circuit boards	Loose, broken, or corroded solder connections; burned circuit boards; burned, broken, or cracked circuit-run plating	Remove failed modules and replace with a new module.
Resistors	Burned, cracked, broken, blistered condition	Replace failed module and replace with a new module.
Solder connections	Cold solder or rosin joints	Resolder joint and clean with isopropyl alcohol.
Capacitors	Damaged or leaking cases; corroded solder on leads or terminals	Remove damaged module and replace with a new module from the factory.
Semiconductors	Loosely inserted in sockets.; distorted pins.	Firmly seat loose semiconductors. Remove devices that have distorted pins. Carefully straighten pins (as required to fit the socket), using long-nose pliers, and reinsert firmly. Ensure that straightening action does not crack pins, causing them to break off.
Wiring and cables	Loose plugs or connectors; burned, broken, or frayed wiring.	Firmly seat connectors. Repair or replace modules with defective wires or cables.
Chassis	Dents, deformations, and damaged hardware	Straighten, repair, or replace defective hardware.

Cleaning Procedure — Interior. If, after doing steps 1 and 2, a module is clean upon inspection, skip the remaining steps.

1. Blow off dust with dry, low-pressure, deionized air (approximately 9 psi).
2. Remove any remaining dust with a lint-free cloth dampened in isopropyl alcohol (75% solution), and rinse with warm deionized water. (A cotton-tipped applicator is useful for cleaning in narrow spaces and on circuit boards.)
3. If steps 1 and 2 do not remove all the dust or dirt, the AWG2021 may be spray washed using a solution of 75% isopropyl alcohol by doing step 4 through 8.

4. Gain access to the parts to be cleaned by removing easily accessible shields and panels (see *Removal and Installation Procedures* in this section).
5. Spray wash dirty parts with the isopropyl alcohol, and wait 60 seconds for the majority of the alcohol to evaporate.
6. Use hot (48.9° C to 60° C/120° F to 140° F) deionized water to thoroughly rinse the parts.
7. Dry all parts with low-pressure, deionized air.
8. Dry all components and assemblies in an oven or drying compartment using low-temperature (51.7° C to 65.6° C/125° F to 150° F) circulating air.

Lubrication. There is no periodic lubrication required for the AWG2021.

Removal and Installation Procedures

This subsection describes removing and installing the mechanical and electrical modules in the AWG2021.

Preparation

This subsection contains the following information:

- Preparatory information needed to properly do the procedures that follow
- A list of equipment required when removing modules
- Module locator diagrams for finding each module in the AWG2021
- Procedures for removing and installing electrical and mechanical modules



WARNING. *To avoid possible personal injury or damage to AWG2021 components, read the Preparation for Use subsection on page 2-1, and Preventing ESD on page 6-2. Before doing this or any other procedure in this manual, read the General Safety Summary and the Service Safety Summary, beginning on page ix near the beginning of this manual.*

To avoid possible personal injury or death, disconnect the power cord from the line voltage source before doing any procedures in this section.

List of Mechanical Parts

Section 10, *Mechanical Parts List*, lists all mechanical parts in the AWG2021.

General Instructions

NOTE. *Read these general instructions before removing a module.*

First read over the *Summary of Procedures* that follows to understand how the procedures are organized. Then read *Equipment Required* to find out the tools needed to remove and install modules.

To remove a module, begin by doing the *Access Procedure* (on page 6-12). By following the instructions in that procedure, you can remove the desired module without unnecessarily removing other modules.

Summary of Procedures

The *Access Procedure* on page 6–12 identifies the procedure for removing each module. These categories separate the procedures based on their location in the AWG2021.

- *Procedures for External Modules* on page 6–15 describes how to remove modules which can be removed without internal access to the AWG2021.
- *Procedures for Internal Modules* on page 6–26 describes how to remove modules which require internal access to the AWG2021.

Equipment Required

The removal of most modules in the AWG2021 requires only a screwdriver handle mounted with a size T-15, Torx® screwdriver tip. Use this tool whenever a procedure step instructs you to remove or install a screw, unless a different size screwdriver is specified in that step. The first step of a module procedure lists all equipment required to remove and reinstall the module.

Table 6–4: Equipment Required

Name	Description	Part Number
Screwdriver handle	Accepts Torx®-driver bits	003-0524-00
T-9 Torx® tip	Torx®-driver bit for T-9 size screw heads	003-0965-00
T-10 Torx® tip	Torx®-driver bit for T-10 size screw heads	003-0815-00
T-15 Torx® tip	Torx®-driver bit for T-15 size screw heads	003-0966-00
#1 Phillips tip	Phillips-driver bit for #1 size screw heads	003-0335-00
Flat-bladed screwdriver	Screwdriver for removing standard-headed screws	
Hex wrench, 0.050 inch	Standard tool	
Hex wrench, 1/16 inch	Standard tool	
Needle-nose pliers	Standard tool	
Nut driver, 1/2 inch	Standard tool	
Nut driver, 1/4 inch	Standard tool	
Nut driver, 5/16 inch	Standard tool	
Nut driver, 5 mm	Standard tool	
Open-end wrench 1/2 inch	Standard tool	
Soldering iron	Standard tool	

AWG2021 Orientation

In this manual, procedures refer to “front,” “back,” “top,” etc. of the AWG2021. Figure 6–1 shows how the sides are referenced.

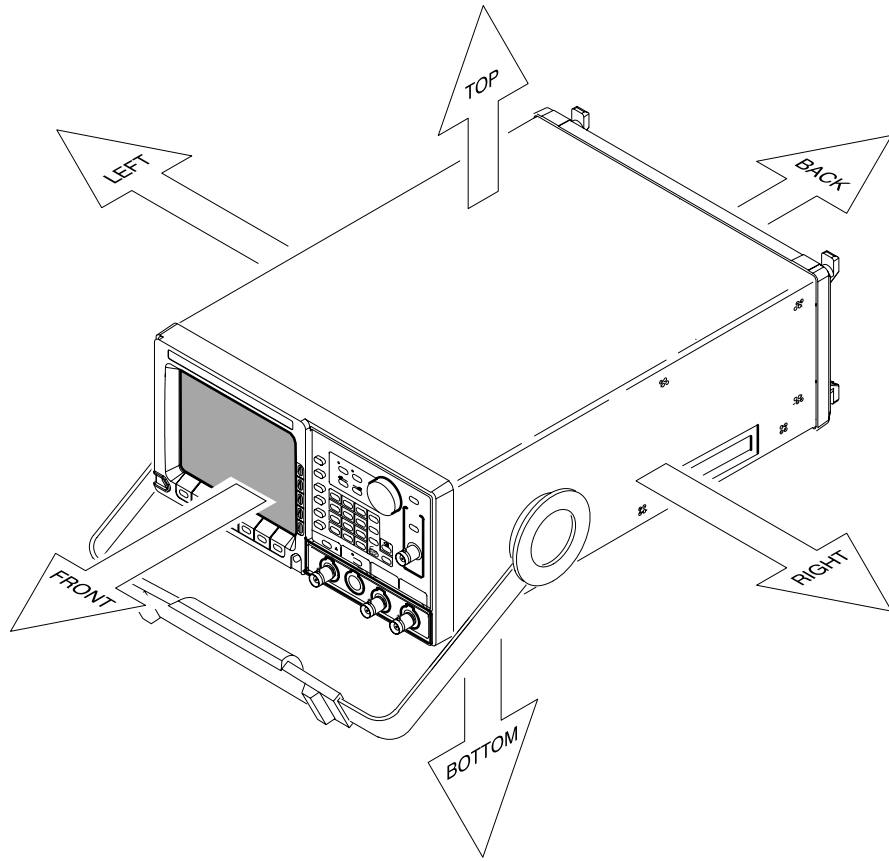

Figure 6–1: AWG2021 Orientation

Access Procedure

When you have identified the module to be removed for service, read *General Instructions* found on page 6-9. Then use the flowchart in Figure 6-2 to determine which procedures to use for removing the module. The removal procedures end with installation instructions.

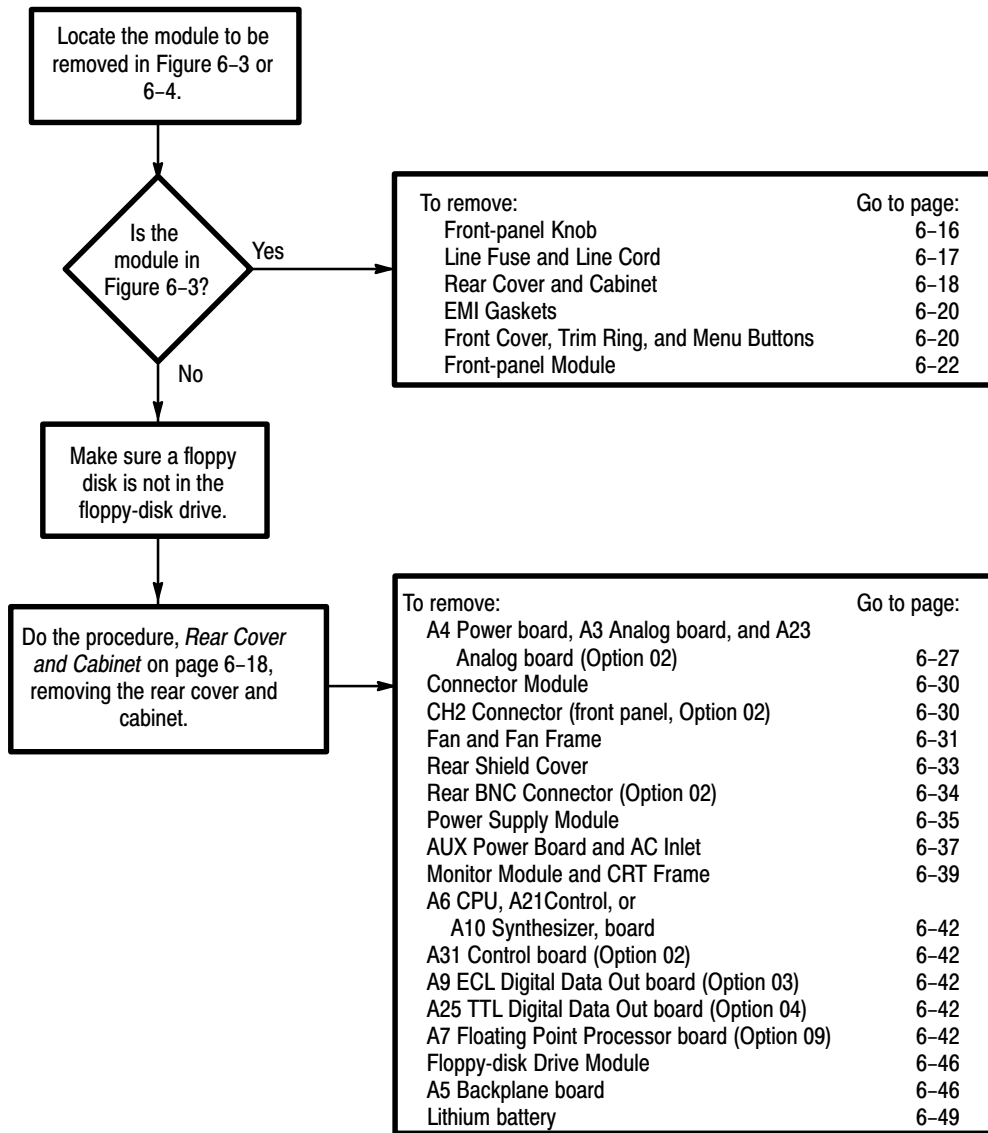

Figure 6-2: Guide to Removal Procedures

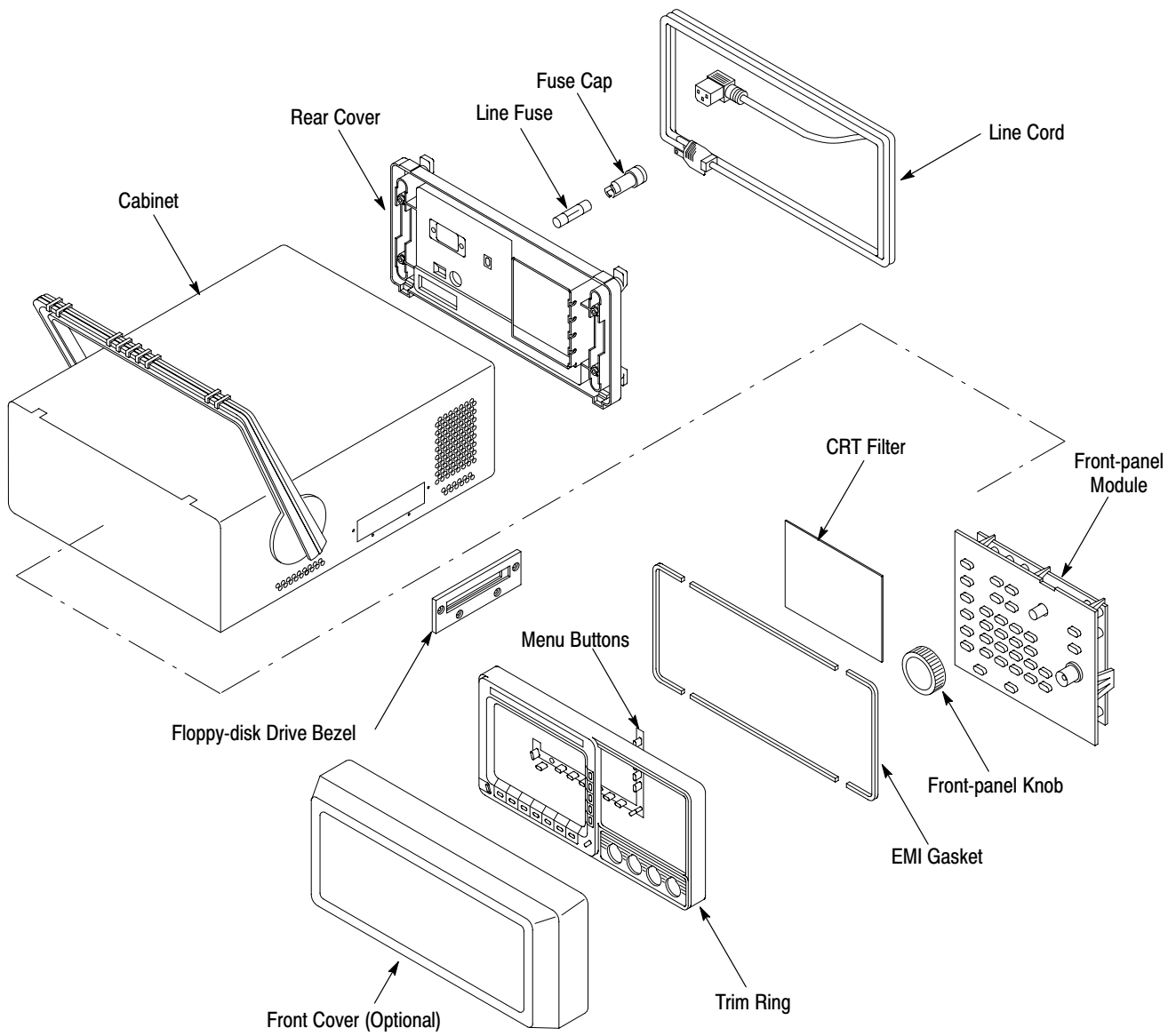

Figure 6-3: External Modules

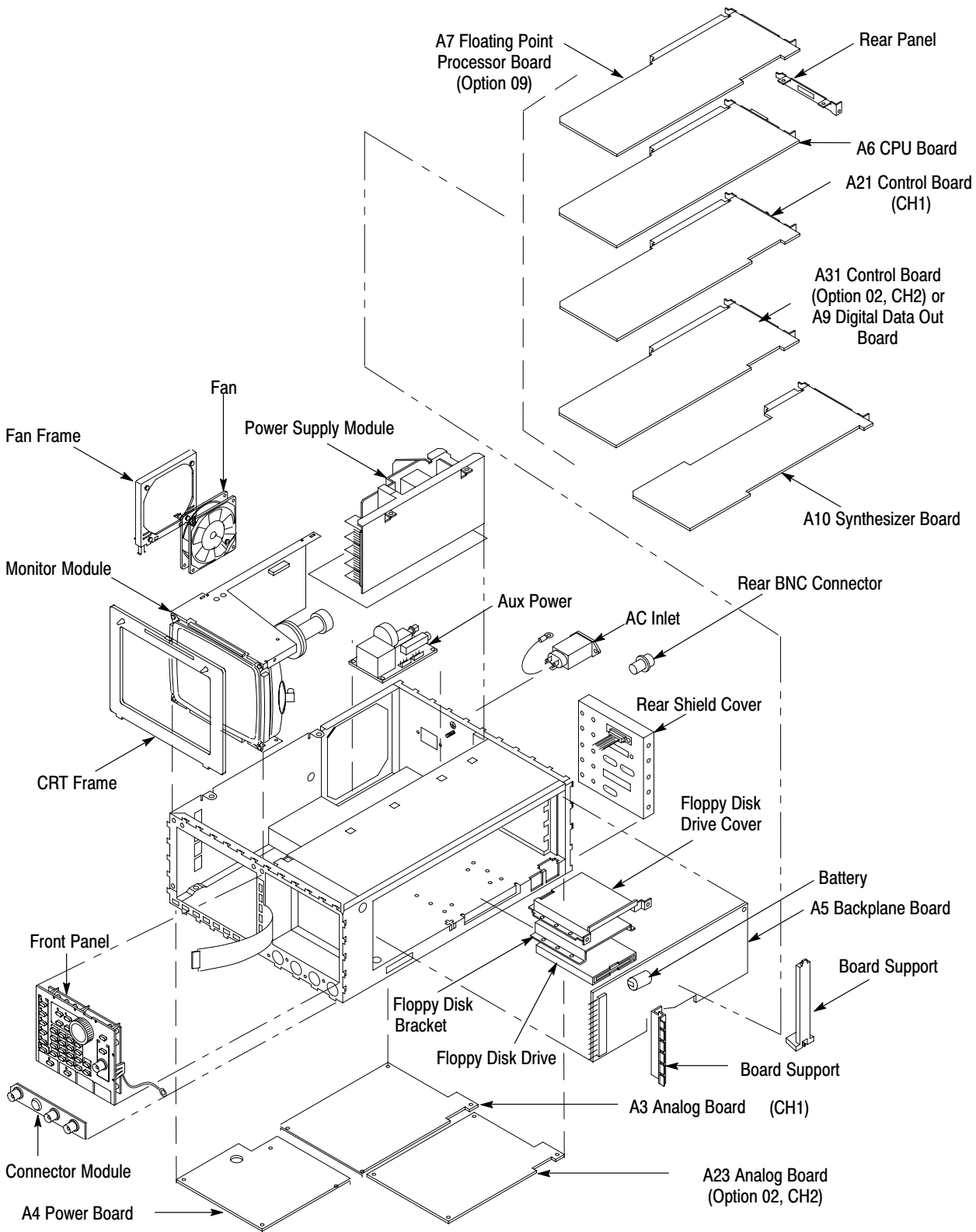

Figure 6-4: Internal Modules

Procedures for External Modules

Do the *Access Procedure* (page 6–12) before doing any procedure in this group.

This group contains the following procedures:

- Front-panel Knob
- Line Fuse and Line Cord
- Rear Cover and Cabinet
- EMI Gaskets
- Front Cover, Trim Ring, and Menu Buttons
- Front-panel Module

Front-panel Knob

1. *Assemble equipment and locate modules to be removed:* You will need a $\frac{1}{16}$ -inch hex wrench to do this procedure. Find the front-panel knob on the front panel in the locator diagram, *External Modules*, Figure 6-3.
2. *Orient instrument:* Set the AWG2021 with the bottom down on the work surface and the front facing you (see Figure 6-5).
3. *Remove front cover:* If the optional front cover is installed, grasp the front cover by the left and right edges and snap it off of the trim ring. (When reinstalling, align and snap back on.)
4. *Remove knob:* Loosen the setscrew securing the knob using the $\frac{1}{16}$ -inch hex wrench. Pull the knob toward you to remove it.
5. *Reinstallation:* Place the knob onto the shaft, and tighten the setscrew using the $\frac{1}{16}$ -inch hex wrench.

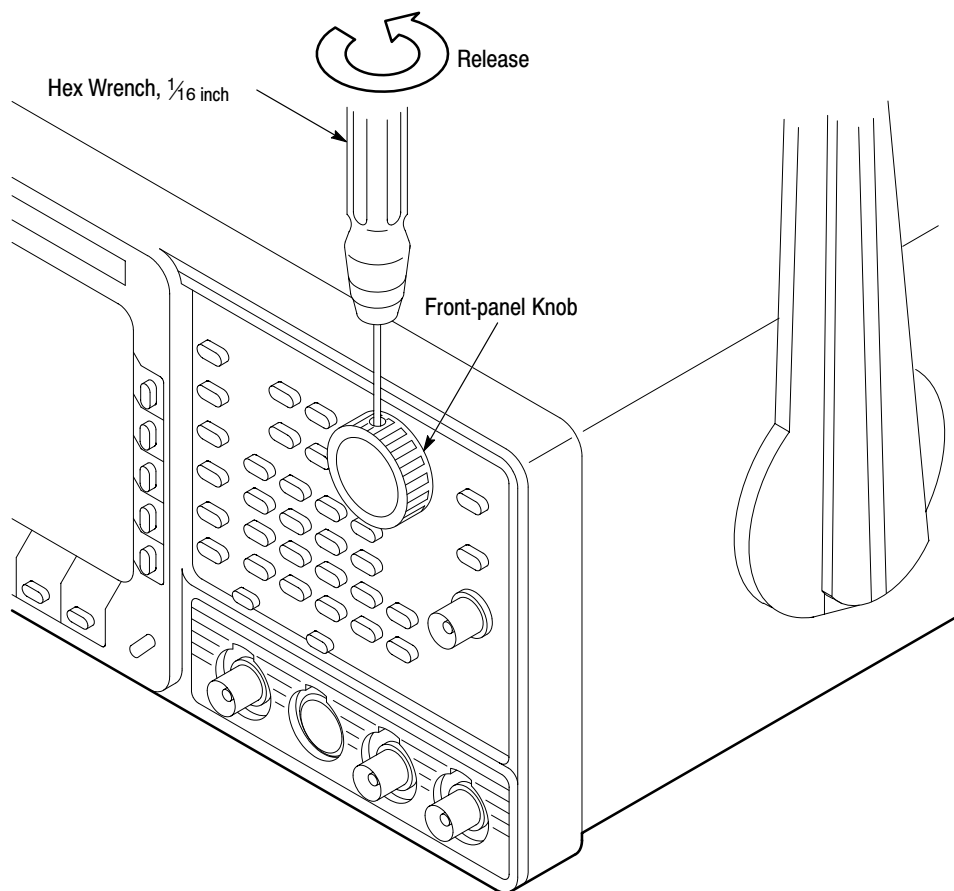
**Figure 6-5: Front-panel Knob Removal**

Line Fuse and Line Cord

1. *Assemble equipment and locate modules to be removed:* You will need a flat-bladed screwdriver to do this procedure. Locate the line fuse and line cord in the locator diagram, *External Modules*, Figure 6-3.
2. *Orient instrument:* Set the AWG2021 with the bottom down on the work surface and the back facing you. If you are servicing the line fuse, do the next step; if you are servicing the line cord, skip to step 4.
3. *Remove line fuse:* Find the fuse cap on the rear panel. See Figure 6-6. Now, remove the fuse cap by turning it counter-clockwise using a flat-bladed screwdriver, and remove the line fuse. Reverse the procedure to reinstall.
4. *Remove line cord:* Find the line cord on the rear cover. See Figure 6-6. Now, remove the line-cord retaining clamp by first unplugging the line cord from the line cord receptacle (1). Next, grasp both the line cord and the retaining clamp and rotate it 90 degrees, counter-clockwise (2). Pull the line cord and clamp away to complete the removal (3). Reverse the procedure to reinstall.
5. *Reinstallation:* Do steps 3 and 4 in reverse order to reinstall the line cord, and then the line fuse.

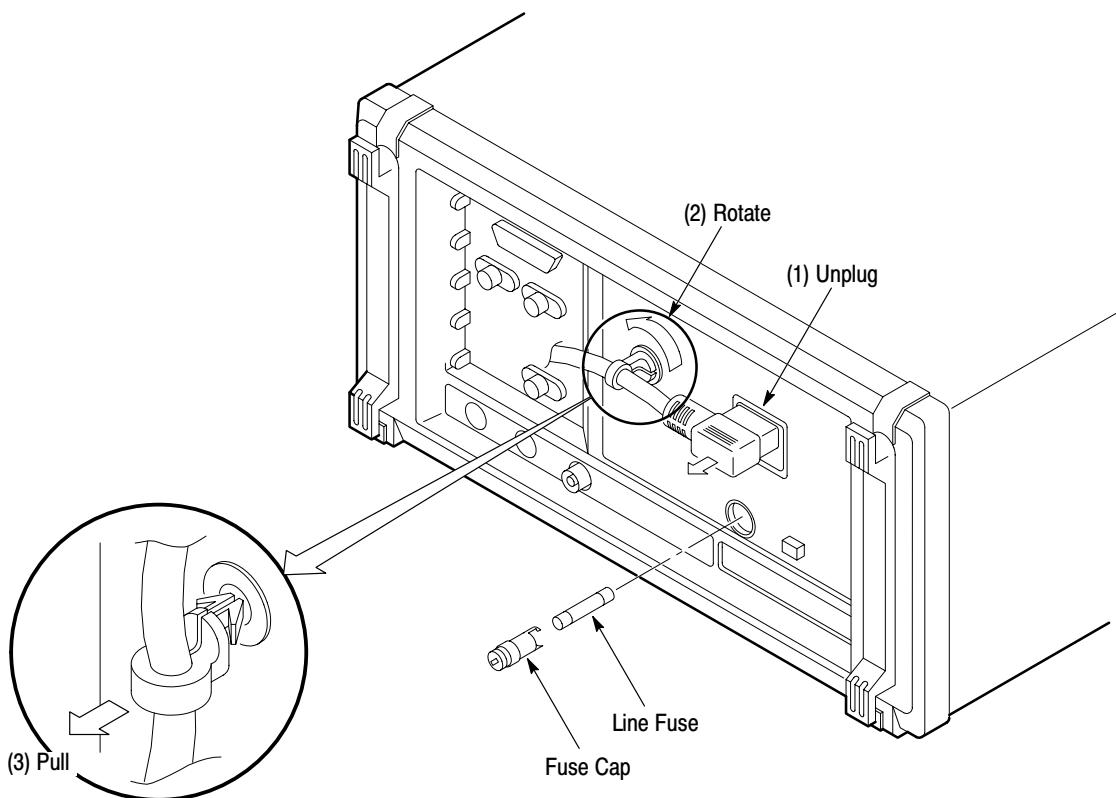
**Figure 6-6: Line Fuse and Line Cord Removal**

Rear Cover and Cabinet

1. *Assemble equipment and locate modules to be removed:*
 - a. You will need a screwdriver with size T-9 and T-15 Torx® tips to do this procedure.
 - b. Make sure the AWG2021 front cover (optional accessory) is installed. If it is not, install it by snapping the edges of the front cover over the trim ring.
 - c. Locate the rear cover and cabinet in the locator diagram, *External Modules*, Figure 6-3.
2. *Orient instrument:* Set the AWG2021 face down, with the front cover on the work surface and the instrument bottom facing you (see Figure 6-7).
3. *Disconnect line cord:* Do the *Line Fuse and Line Cord* procedure on page 6-17, removing only the line cord.
4. *Remove rear cover:* Using a screwdriver with a size T-15 Torx® tip, remove the four screws securing the rear cover to the instrument. Lift off the rear cover.
5. *Orient instrument:* Set the AWG2021 face down, with the front cover on the work surface and right side facing you.
6. *Remove floppy disk drive bezel:* Using a screwdriver with a size T-9 Torx® tip, remove the four screws securing the floppy-disk drive bezel to the cabinet. Lift off the floppy-disk drive bezel.
7. *Remove cabinet:*



CAUTION. *To prevent damaging the eject button, make sure floppy disk is not inserted in the floppy disk drive, before removing the cabinet from the AWG2021.*

- a. Using a screwdriver with a size T-15 Torx® tip, remove the screw securing the left side of the cabinet to the instrument.
 - b. Grasp the right and left edges of the cabinet toward the back.
 - c. Pull upward to slide the cabinet off the instrument. Take care not to bind or snag the cabinet on internal cabling as you remove it.
8. *Reinstall cabinet and rear cover:*
 - a. Do steps 3 through 7 in reverse order to reinstall the cabinet.
 - b. Take care not to bind or snag the cabinet on internal cabling; redress cables as necessary.

- c. When sliding the cabinet, be sure that the front edge of the cabinet aligns with the groove containing the four EMI shields on the trim ring.
- d. When reinstalling the four screws at the rear panel, tighten them to a torque of 10 kg-cm (8.7 in-lbs).
- e. See the procedure, *Line Fuse and Line Cord*, on page 6-17 to reinstall the line cord. This completes the AWG2021 reassembly.

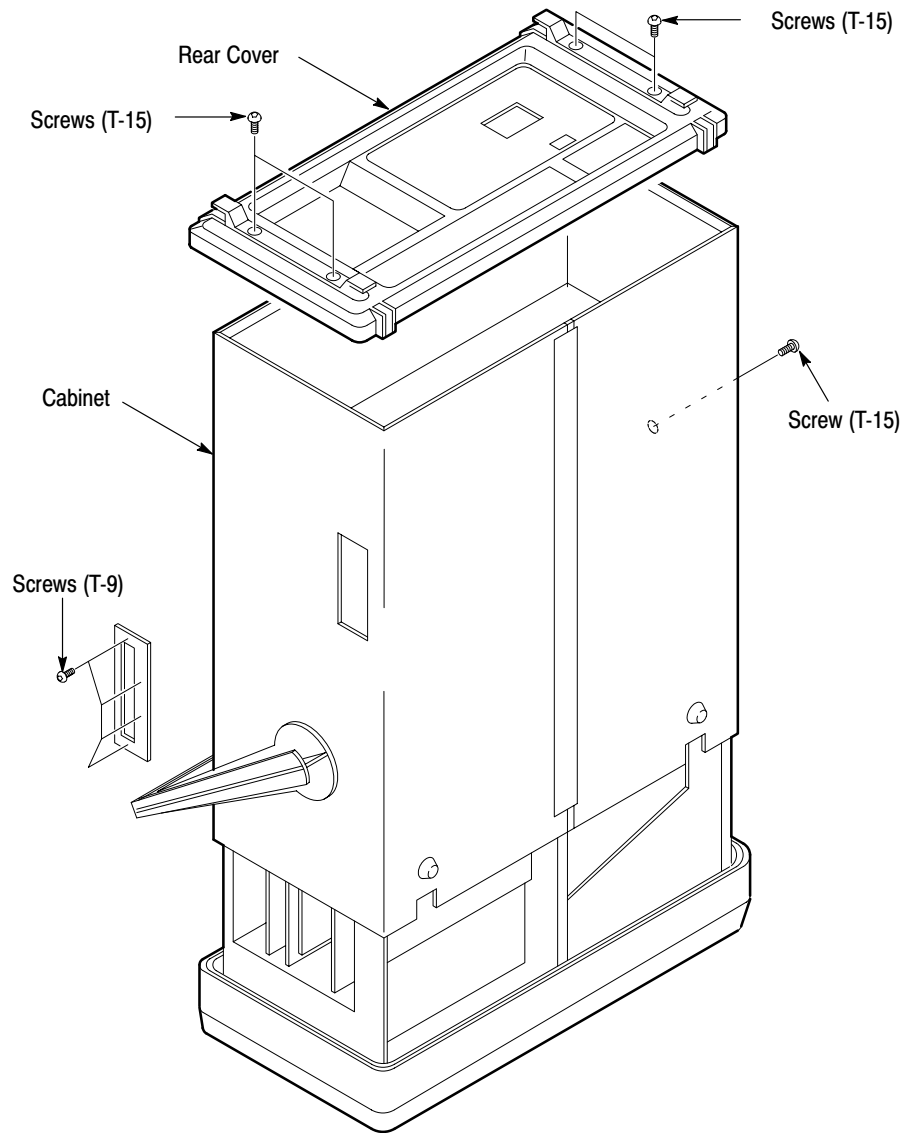

Figure 6-7: Rear Cover and Cabinet Removal

EMI Gaskets

1. *Remove front cover and trim ring:* Do the *Front Cover, Trim Ring, and Menu Buttons* procedure on page 6–20, removing only the front cover and trim ring.



CAUTION. *To prevent exceeding the environmental characteristics for EMI, carefully follow the instructions given, when reinstalling the EMI gaskets and/or the AWG2021 cabinet.*

2. *Remove EMI gaskets:*
 - a. You will need a needle-nose pliers to do this part of the procedure.
 - b. Locate the EMI gaskets in the locator diagram, *External Modules*, in Figure 6–3.
 - c. Use a pair of needle-nose pliers to remove the four sections of EMI gaskets from the groove in the trim ring.
3. *Reinstall EMI gaskets:* Press the EMI gaskets back into the groove in the trim ring.

Front Cover, Trim Ring, and Menu Buttons

1. *Assemble equipment and locate modules to be removed:* No tools are needed. Locate the modules to be removed in the locator diagram, *External Modules*, in Figure 6–3.
2. *Orient instrument:* Set the AWG2021 with the back down on the work surface and bottom facing you (see Figure 6–8).
3. *Remove front cover:* If the optional front cover is installed, grasp the front cover by the left and right edges and snap it off of the trim ring. (When reinstalling, align and snap back on.)
4. *Remove front-panel knob:* Do the *Front-panel Knob* procedure, on page 6–16.

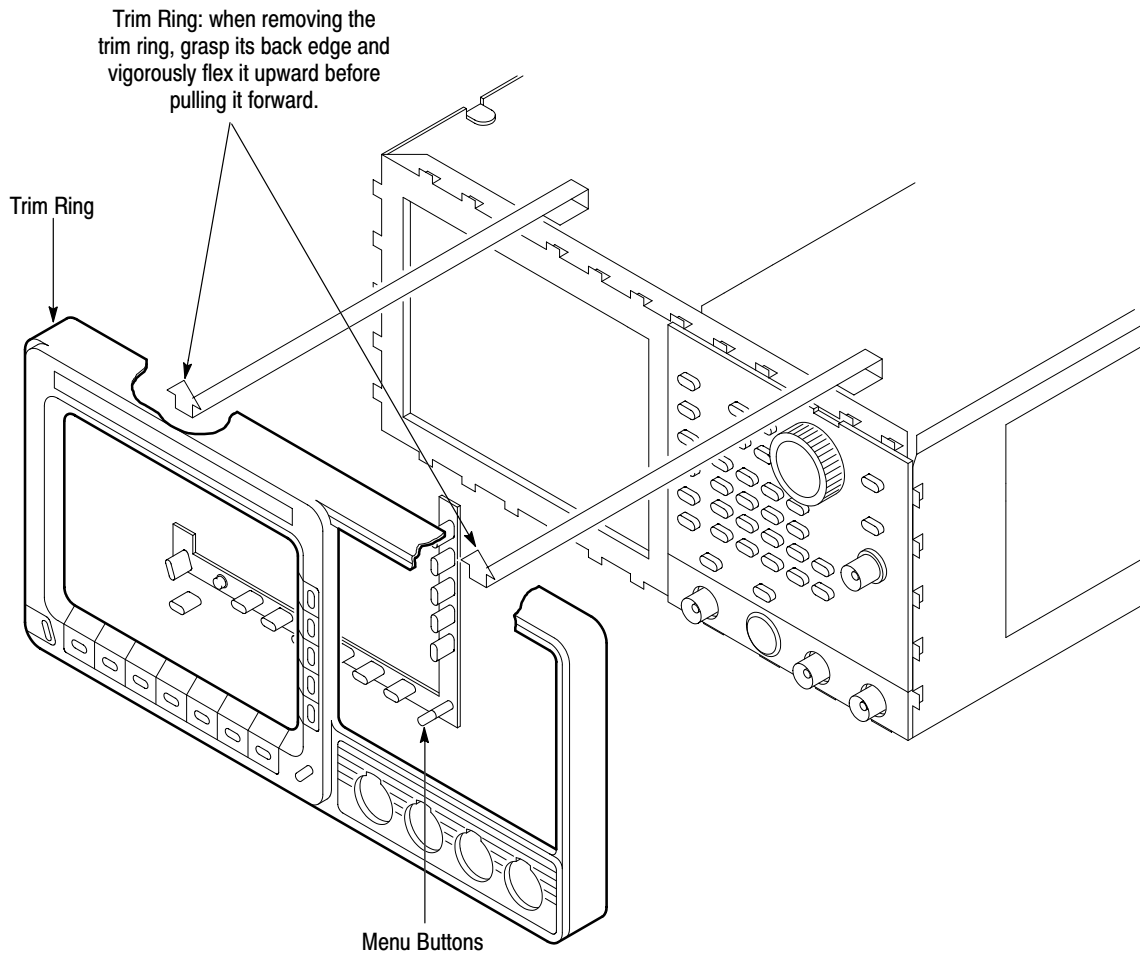

Figure 6-8: Front Cover, Trim Ring, and Menu Button Removal (Front Cover not Shown)



CAUTION. To prevent contaminating AWG2021 parts, do not touch the carbon contact points on the menu buttons installed in the trim ring. Also, do not touch the contacts on the flex circuit exposed when you remove the trim ring.

5. *Remove trim ring:* Grasp the trim ring by the top edge and pry it up and lift it forward to snap it off of the trim ring. If servicing the menu buttons, lift them out of the trim ring. (When reinstalling, reinsert the menu buttons, align the trim ring to the chassis and press it back on.)
6. *Reinstallation:* Do steps 3–5 in reverse order to reinstall the menu buttons, trim ring and the front cover, following the reinstallation instructions found in each step.

Front-panel Module

NOTE. *This procedure includes removal and reinstallation instructions for the front-panel module and front-panel buttons. Unless either of those modules are being serviced, do not do step 6, “Further disassembly of Front-panel Module.”*

1. *Assemble equipment and locate modules to be removed:*
 - a. You will need a flat-bladed screwdriver and a 0.05-inch and $\frac{1}{16}$ -inch hex wrench to do this procedure.
 - b. Locate the modules to be removed in the locator diagram, *External Modules*, in Figure 6-3.
 - c. Do the procedure, *Front Cover, Trim Ring, and Menu Buttons*, steps 1-6 (immediately preceding this procedure).
2. *Remove front-panel knob:* Do the *Front-panel Knob* procedure, on page 6-16.
3. *Remove front cover, trim ring, and menu buttons:* Do the *Front Cover, Trim Ring, and Menu Buttons* procedure on page 6-20 removing only the module(s) you want to service.
4. *Orient instrument:* Set the AWG2021 with the bottom down on the work surface and the front facing you.
5. *Remove front-panel module:*
 - a. As shown in Figure 6-9, release the snap at the right of the front-panel module using a flat-bladed screwdriver. Lift the front-panel module out of the chassis until you can reach the interconnect cable.
 - b. Disconnect the ribbon interconnect cable at J101 and flexible board connector at JP301 on the A12 Keyboard assembly. Disconnect the interconnect cable at the TRIGGER INPUT connector.
 - c. Lift the front-panel module out of the chassis to complete the removal.

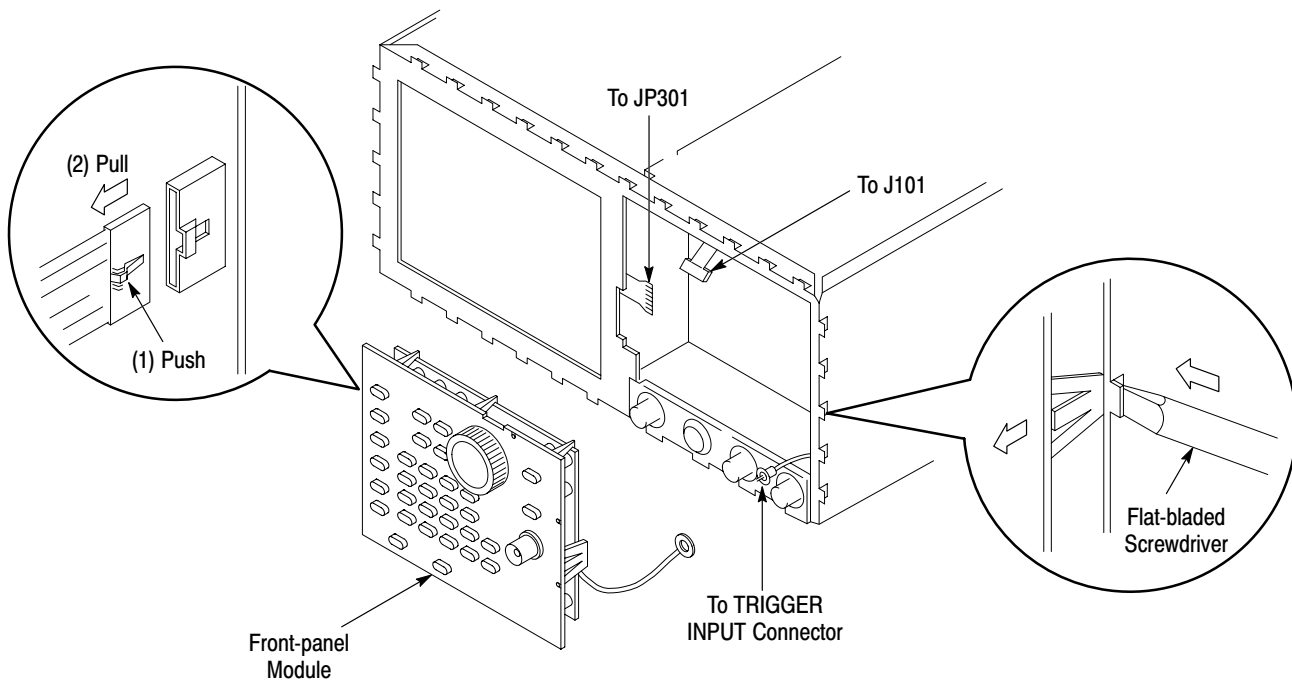

Figure 6-9: Front-panel Module Removal

6. *Further disassembly of front-panel module:* If the front-panel module or the front-panel buttons are to be serviced, do the following substeps:
 - a. Remove the front-panel knob from the front-panel module using the method described in the procedure, *Front-panel Knob*, on page 6-16.
 - b. Remove the setscrew completely from the extension using the 0.05-inch hex wrench, and then remove the extension from the shaft of the rotary switch.
 - c. As shown in Figure 6-10, release the four hooks, and then remove the A12 Keyboard from the chassis.

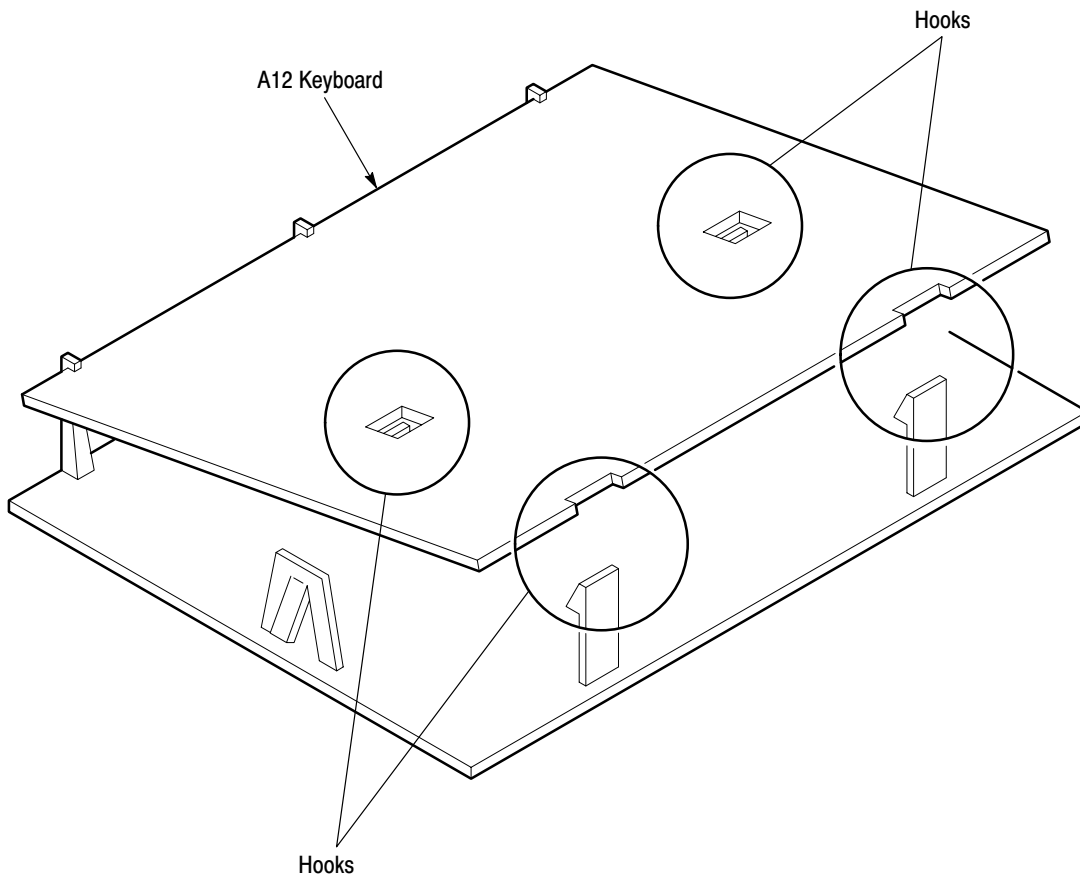

Figure 6-10: A12 Keyboard Removal

- d. Now disassemble the front-panel module components using Figure 6-11 as a guide. Reverse the procedure to reassemble.

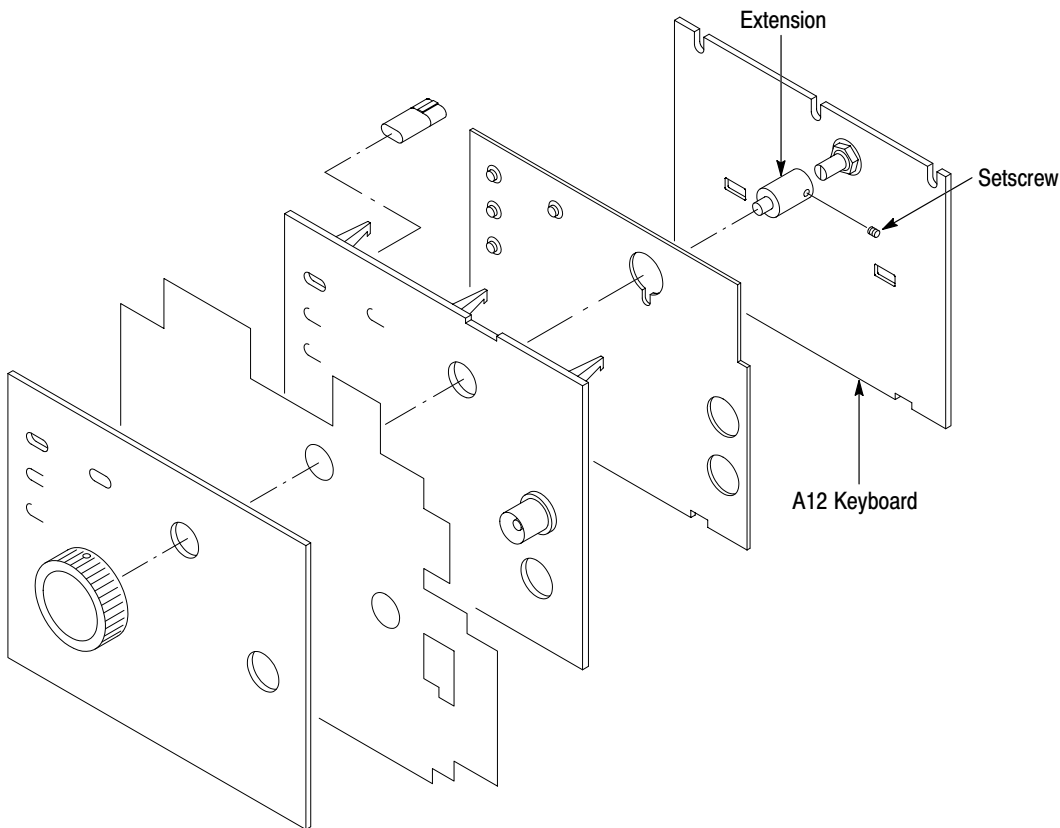

Figure 6-11: Disassembly of Front-panel Module

7. *Reinstallation:* If the front-panel module was further disassembled in step 6, then reverse substeps 6a–6d to reassemble, using Figure 6–11 as a guide. Then do the substeps in step 3 in reverse order, reversing the order of the items in each substep. Last, reinstall the trim ring and, if desired, the front cover, referring to the procedure, *Front Cover, Trim Ring, and Menu Buttons* (page 6–20).

Procedures for Internal Modules

Do the *Access Procedure* (on page 6–12) before doing any procedure in this group.

This part contains the following removal and installation procedures. The procedures are presented in the order listed:

- A4 Power Board, A3 Analog Board, and A23 Analog Board (Option 02)
- Connector Module
- Fan and Fan Frame
- Rear Shield Cover
- Rear BNC Connector
- Power Supply Module
- AC Inlet and AUX Power Board
- Monitor Module and CRT Frame
- Circuit Boards:
 - A6 CPU Board
 - A2 Memory Board
 - A21 Control Board
 - A10 Synthesizer Board
 - For Option 02: A22 Memory Board and A31 Control Board
 - For Option 03: A9 ECL Digital Data Out Board
 - For Option 04: A25 TTL Digital Data Out Board
 - For Option 09: A7 Floating Point Processor Board
- A5 Backplane Board
- Lithium Battery
- Floppy Disk Drive Module

**A4 Power Board,
A3 Analog Board, and
A23 Analog Board
(Option 02)**

1. *Assemble equipment and locate modules to be removed:*
 - a. You will need a screwdriver with a size T-15 Torx® tip to do this procedure.
 - b. Locate the modules to be removed in the locator diagram, *Internal Modules*, Figure 6-4.
2. *Orient instrument:* Set the AWG2021 with the top down on the work surface and the right side facing you. If you are not servicing the A4 Power board, skip to step 4.
3. *Remove A4 Power board:*
 - a. Disconnect the two interconnect cables at J300 and J310 on the A4 Power board. See Figure 6-12.

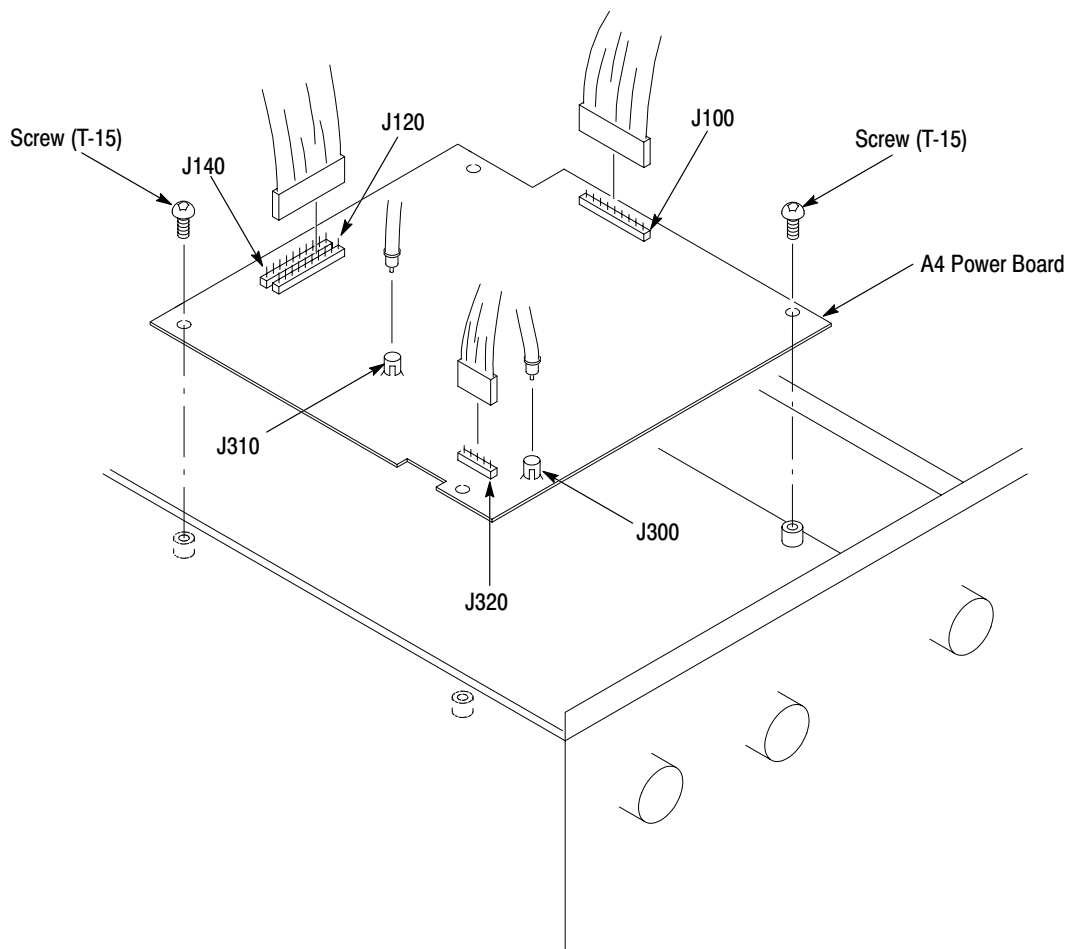
**Figure 6-12: A4 Power Board Removal**

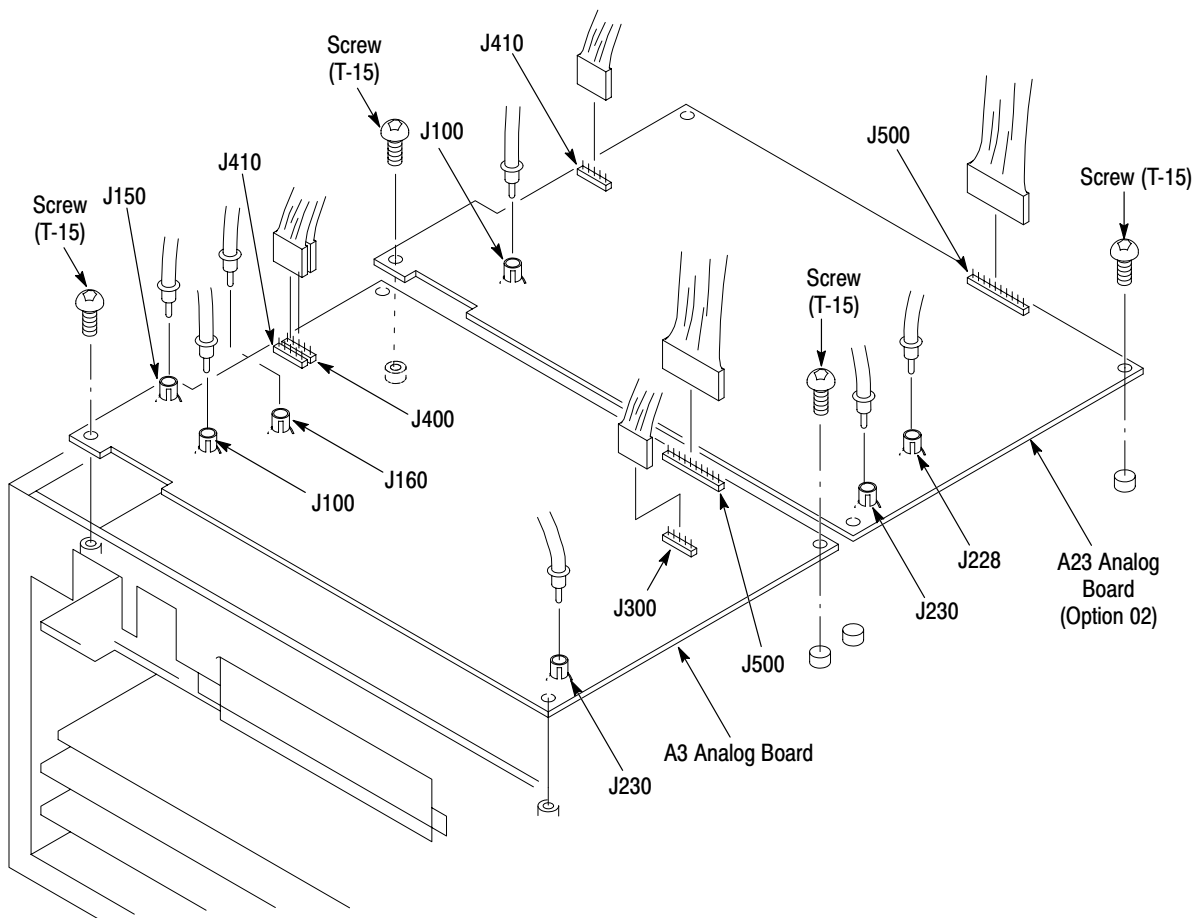

Figure 6-13: A3/A23 Analog Board Removal

6. *Reinstallation:* If the AWG2021 includes Option 02, do substeps 5a–5d to reinstall the A23 Analog board. Do substeps 4a–4d in reverse order to reinstall the A3 Analog board; then, do substeps 3a–3d in reverse order to reinstall the A4 Power board.

Connector Module

1. *Assemble equipment and locate modules to be removed:*
 - a. You will need a screwdriver with a size T-9 Torx® tip and a ½-inch nut driver to do this procedure.
 - b. Locate the modules to be removed in the locator diagram, *Internal Modules*, in Figure 6-4.
2. *Remove front-panel knob:* Do the *Front-panel Knob* procedure, on page 6-16.
3. *Remove front cover, trim ring, and menu buttons:* Do the *Front Cover, Trim Ring, and Menu Buttons* procedure on page 6-20.
4. *Orient instrument:* Set the AWG2021 with the top down on the work surface and the right side facing you.
5. *Remove connector module:*
 - a. Disconnect the interconnect cable at the CH1 Waveform Output connector. See Figure 6-14. For an AWG2021 with Option 02, disconnect the interconnect cable at the CH2 Waveform Output connector.

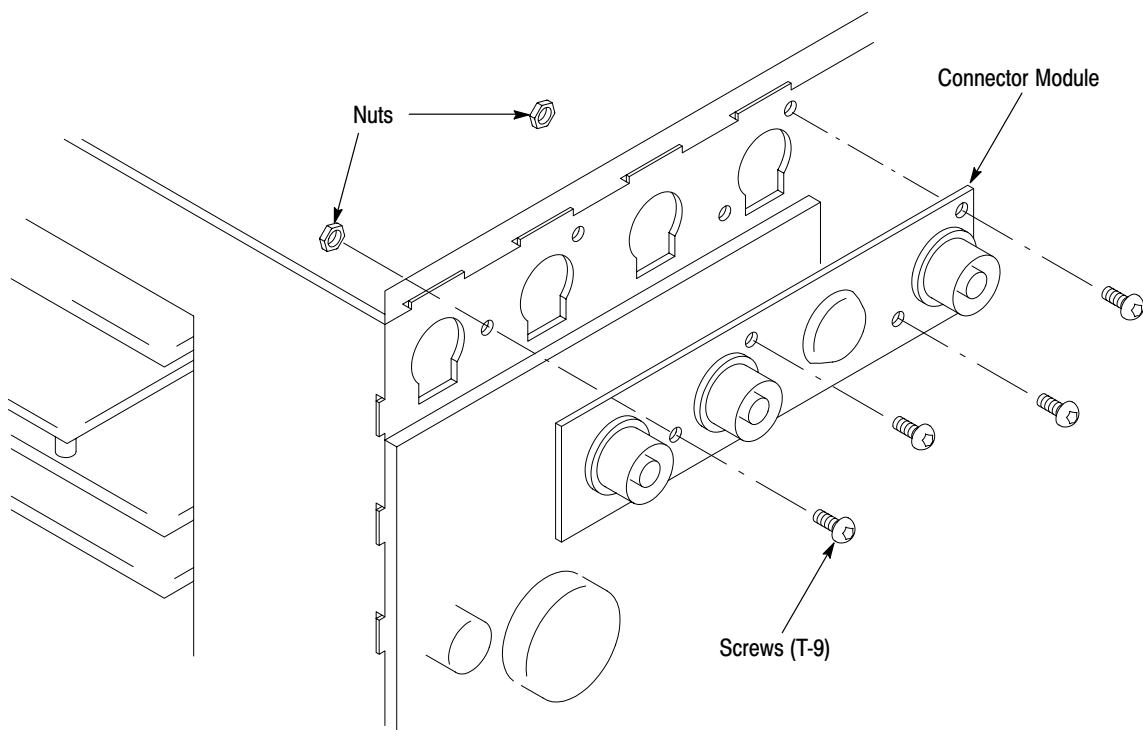

Figure 6-14: Connector Module Removal

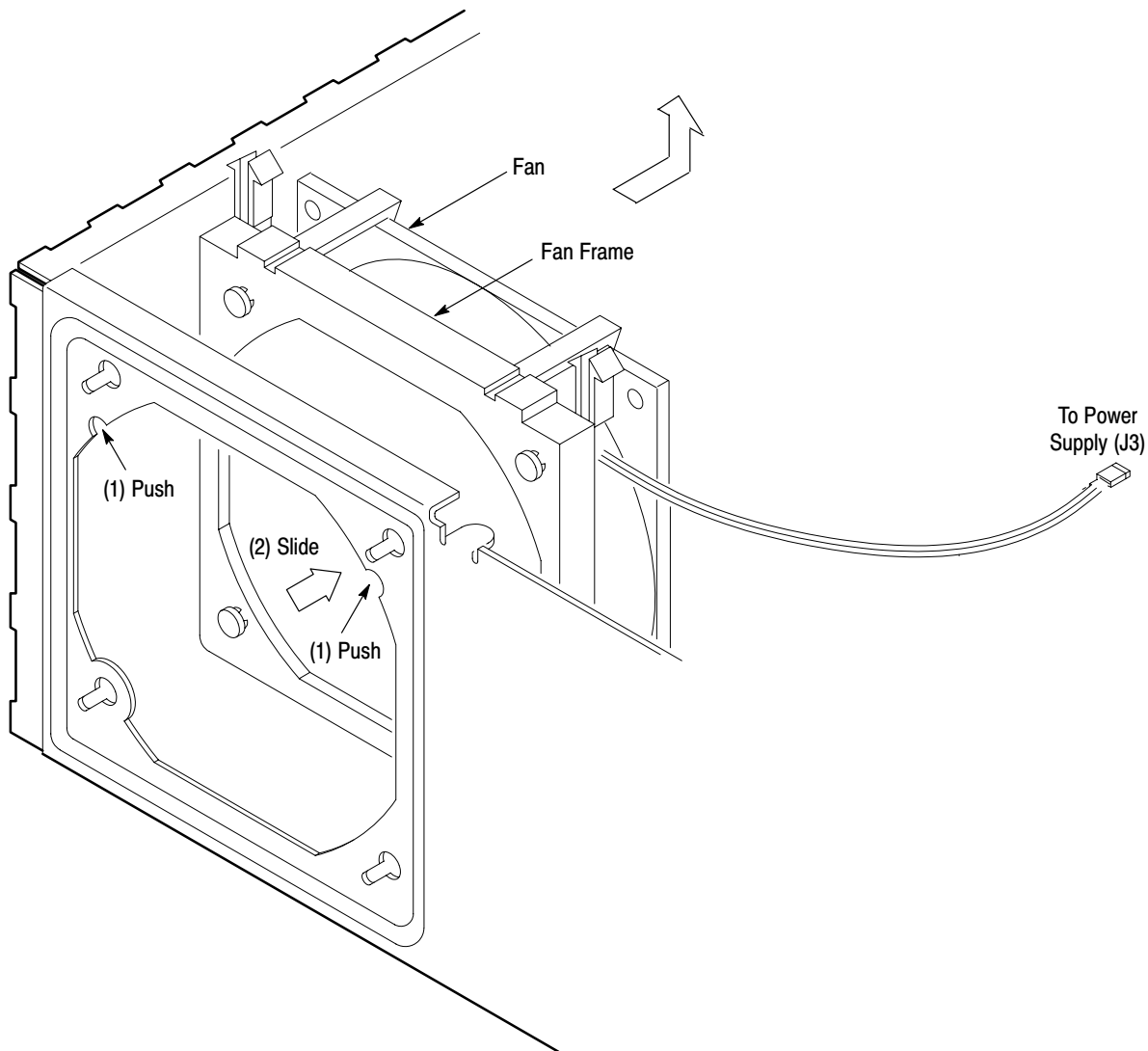

Figure 6-15: Fan and Fan Frame Removal

4. Reinstallation:

- a. Secure the fan to the fan frame.
- b. Connect the cable (J3) to power supply module.
- c. Align the four protrusions of the fan frame with the holes of the chassis. Slide the fan and fan frame to the lower left until the fan is in place.

Rear Shield Cover

1. *Assemble equipment and locate modules to be removed:*
 - a. You will need a screwdriver with a size T-15 Torx® tip and a 1/4-inch nut driver, a 5 mm nut driver, and a 1/2-inch nut driver to do this procedure.
 - b. Locate the modules to be removed in the locator diagram, *Internal Modules*, Figure 6-4.
2. *Orient instrument:* Set the AWG2021 with the bottom down on the work surface and the back facing you (see Figure 6-16).
3. *Remove rear shield cover:*
 - a. Disconnect the ribbon interconnect cable from J30 on the A6 CPU board. See Figure 6-16.
 - b. Using a screwdriver with a size T-15 Torx® tip, remove the five screws securing the rear shield cover to the chassis from the back side.
 - c. Using a screwdriver with a size T-15 Torx® tip, remove the five screws securing the rear shield cover to the chassis from the left side.

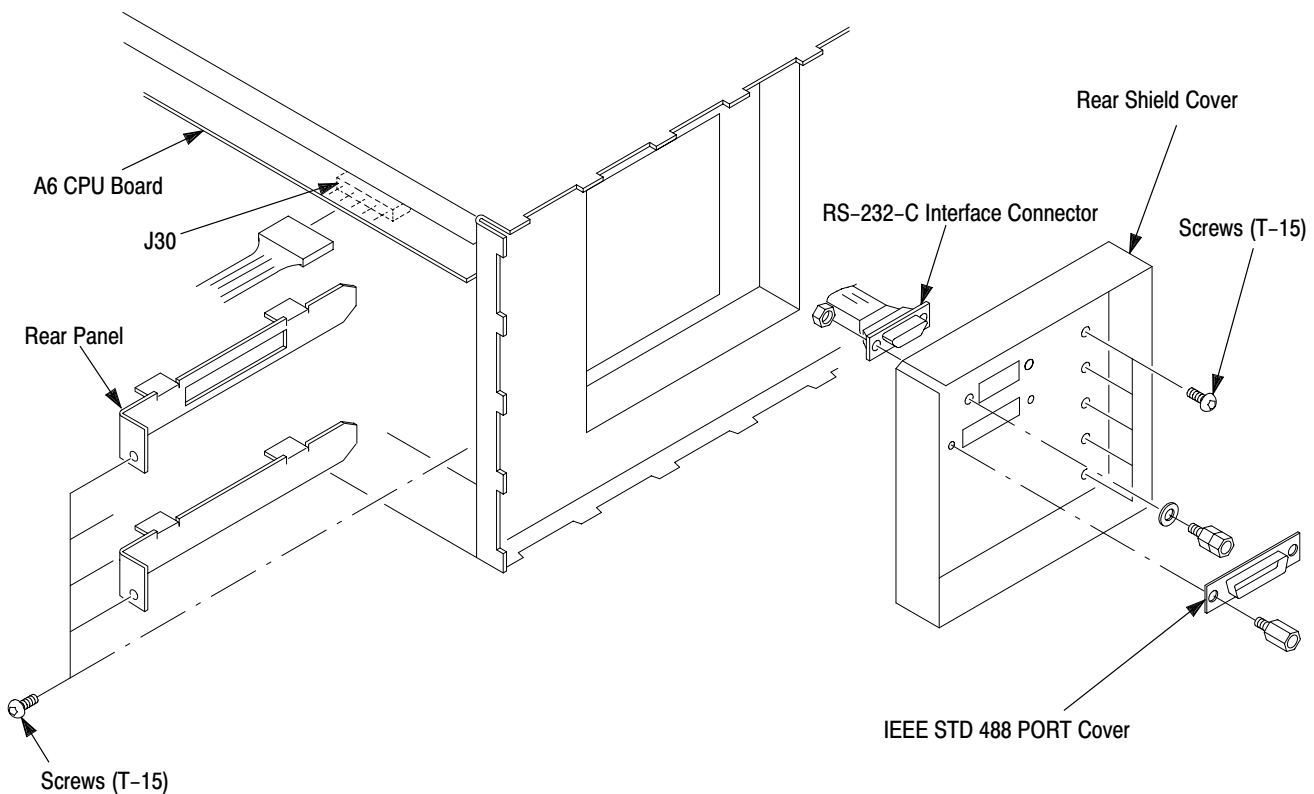
**Figure 6-16: Rear Shield Cover Removal**

- d. Using a $\frac{1}{4}$ -inch nut driver, remove the IEEE STD 488 PORT cover by removing the two spacer posts.
 - e. Grasp the serial interface connector and pull the rear shield cover toward you taking care not to damage the cable. Then remove the rear shield cover.
 - f. You can remove the rear panel of a slot in which no board is mounted.
4. *Remove serial interface connector:* Use a 5 mm nut driver to remove the nut attaching the connector to the rear shield cover; then, remove the connector.
 5. *Reinstallation:* Install the serial interface connector if you removed it by reversing the items in step 4; then, install the rear shield cover by doing substeps 3a–3f in reverse order.

Rear BNC Connector

1. *Assemble equipment and locate modules to be removed:*
 - a. You will need a $\frac{1}{2}$ -inch open-end wrench to do this procedure.
 - b. Locate the modules to be removed in the locator diagram, *Internal Modules*, in Figure 6–4. (An instrument with Option 02 has two additional BNC connectors.)
2. *Orient instrument:* Set the AWG2021 with the top down on the work surface and the left side facing you (see Figure 6–17).
3. *Remove rear BNC connector:*
 - a. Disconnect the interconnect cable at the AM IN connector.
 - b. Using the open-end wrench, remove the nut securing the BNC connector to the chassis. Then, lift the BNC connector out of the chassis to complete the removal.
 - c. For the instrument with Option 02, remove the CH2 MARKER1 OUT and CH2 SYNC OUT connectors using the same procedure.
4. *Reinstallation:* Install the rear BNC connector by doing substeps 3a–3c in reverse order.

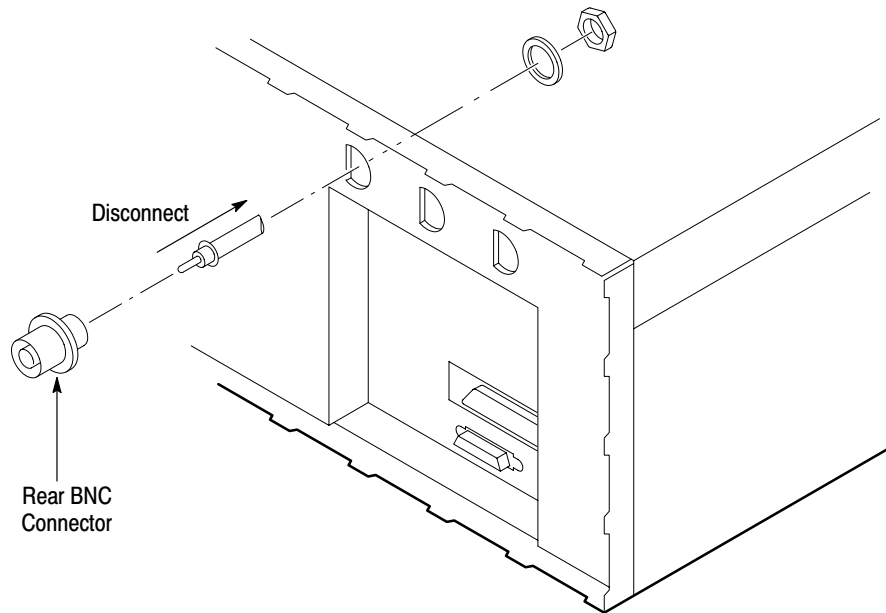

Figure 6-17: Rear BNC Connector Removal

Power Supply Module

1. *Assemble equipment and locate modules to be removed:* You will need a screwdriver with a size T-15 Torx® tip to do this procedure. Locate the modules to be removed in the locator diagram, *Internal Modules*, in Figure 6-4.
2. *Orient instrument:* Set the AWG2021 with the bottom down on the work surface and the left side facing you.
3. *Remove power supply module:*
 - a. Disconnect the ribbon interconnect cable at J1, J3, J4, and J5 on the power supply module. See Figure 6-18.
 - b. Disconnect the flat cable at J2 on the power supply module.
 - c. Using a screwdriver with a size T-15 Torx® tip, remove the two screws attaching the power supply module to chassis.

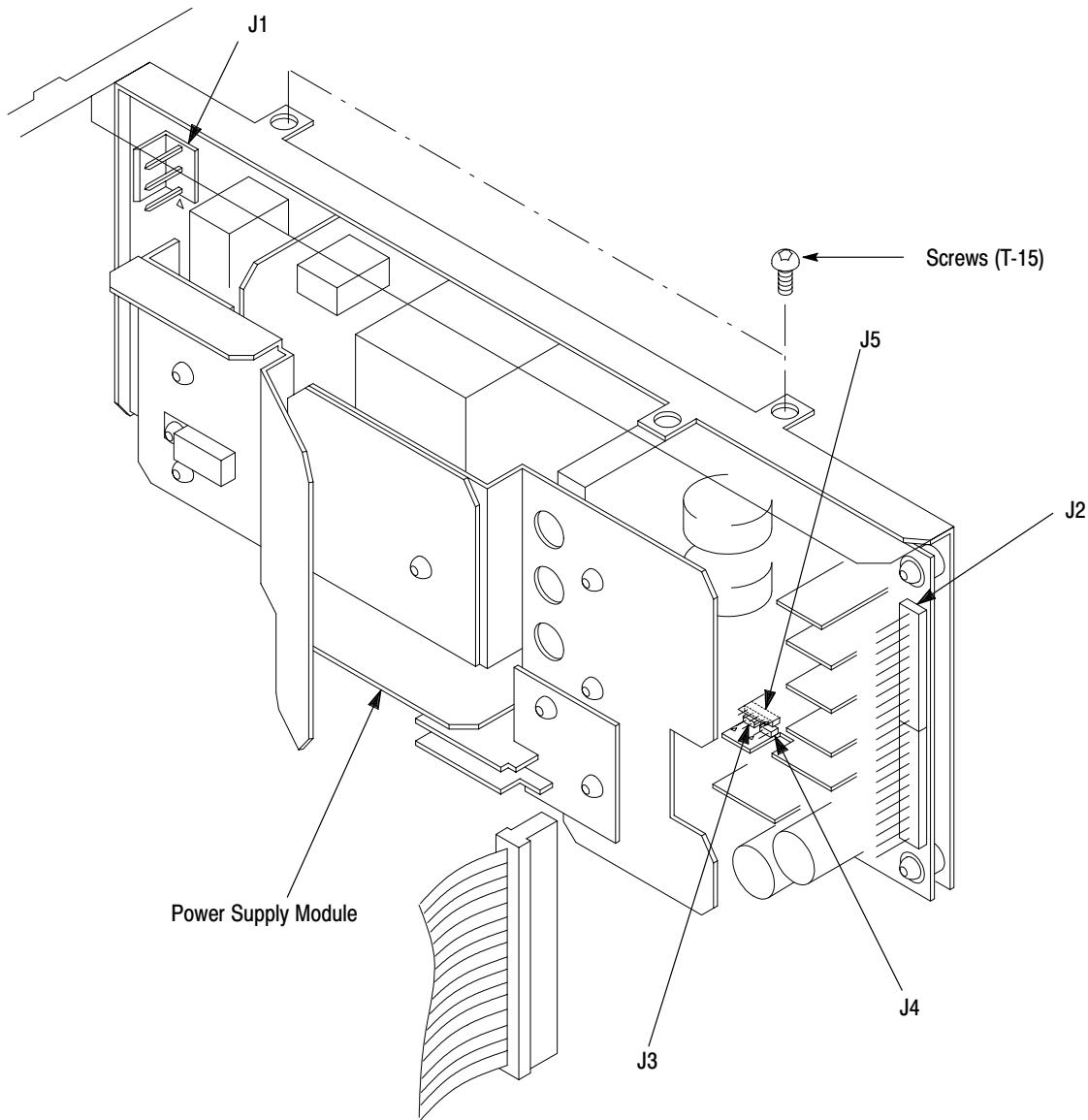

Figure 6-18: Power Supply Module Removal

4. *Reinstallation:* Do substeps 3a–3c in reverse order to reinstall the power supply module.

AC Inlet and AUX Power Board

1. *Assemble equipment and locate modules to be removed:*
 - a. You will need a screwdriver with a size T-15 Torx® tip, a $\frac{5}{16}$ -inch nut driver, and a soldering iron to do this procedure.
 - b. Locate the modules to be removed in the locator diagram, *Internal Modules*, in Figure 6-4.
2. *Remove fan and fan frame:* Do the *Fan and Fan Frame* procedure on page 6-31.
3. *Orient instrument:* Set the AWG2021 with the bottom down on the work surface and the back facing you (see Figure 6-19).
4. *Remove the power supply module:* Do the procedure, *Power Supply Module*, on page 6-35.
5. *Remove AC inlet:*
 - a. Disconnect the interconnect cable at CN1 on the AUX Power board.
 - b. Using a $\frac{5}{16}$ -inch nut driver, remove the nut attaching the ground wire to the chassis.
 - c. Remove the two insulating tubes of cables attached to the AC inlet.
 - d. Unsolder the three interconnect cables attached to the AC inlet.
 - e. Using a screwdriver with a size T-15 Torx® tip, remove the two screws securing the AC inlet to the chassis.
6. *Remove AUX Power board:*
 - a. Disconnect the interconnect cable at CN2 on the AUX Power board.
 - b. Remove the three screws attaching the AUX Power board to the chassis.
 - c. Lift the AUX Power board up and away from the chassis to complete the removal.

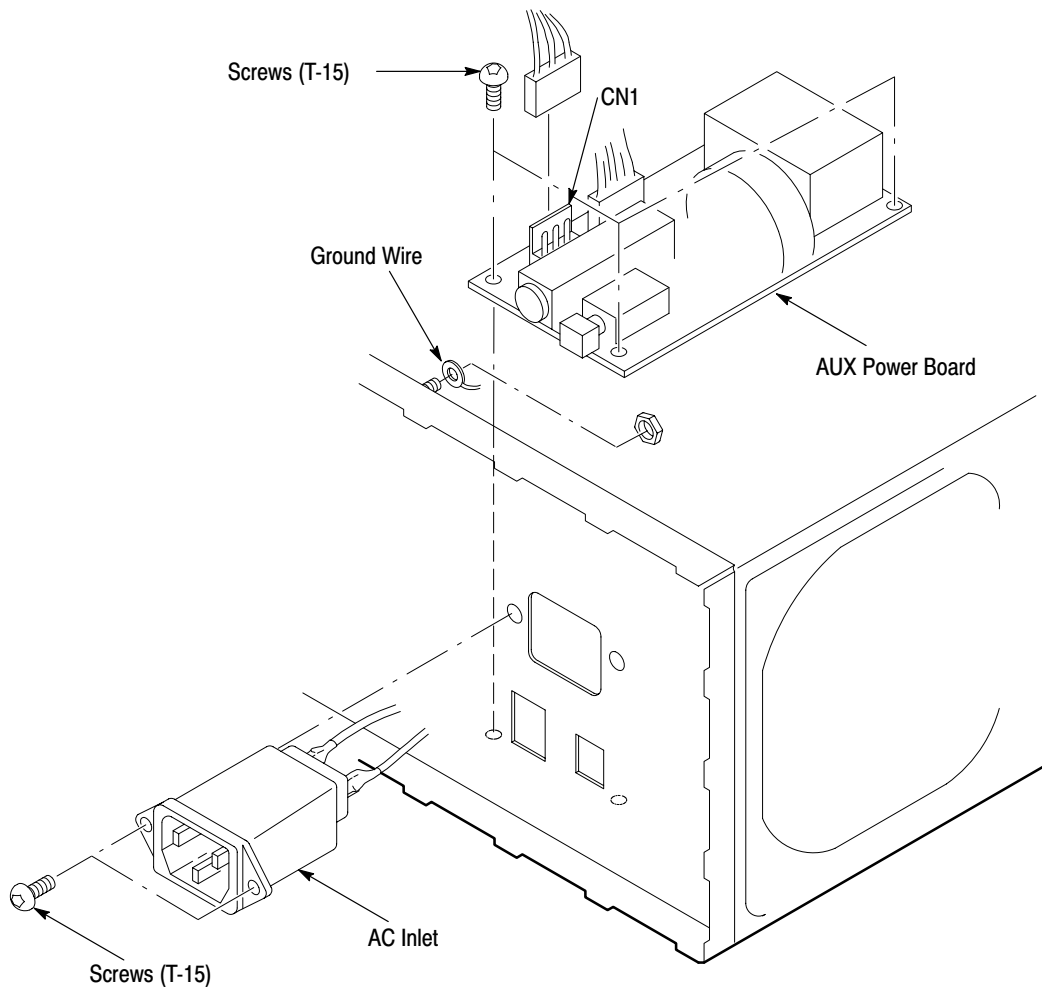

Figure 6-19: AUX Power Board and AC Inlet Removal

7. Reinstallation:

- a.** Install the AUX Power board by doing substeps 6a–6c in reverse order.
- b.** Install the AC Inlet by doing substeps 5a–5e in reverse order.

**Monitor Module and CRT
Frame**

1. *Assemble equipment and locate modules to be removed:*
 - a. You will need a screwdriver with a size T-15 Torx® tip to do this procedure.
 - b. Locate the modules to be removed in the locator diagram, *Internal Modules*, in Figure 6-4.
2. *Remove front cover, trim ring, and menu buttons:* Do the *Front Cover, Trim Ring, and Menu Buttons* procedure on page 6-20.
3. *Orient instrument:* Set the AWG2021 with the bottom down on the work surface and the left side facing you.
4. *Remove monitor module:*

NOTE. Take care not to damage the CRT surface when installing or removing the monitor module.

- a. Disconnect the ribbon interconnect cable at J901 on the monitor module. See Figure 6-20.
- b. Remove the five screws securing the monitor module top and bottom to the chassis.
- c. Release the snap at the right of the front-panel module and shift the assembly. Insert the screwdriver with a size T-15 Torx® tip into the right hole of the chassis, and then remove the screw securing the monitor module.
- d. Lift the monitor module up and away from the chassis to complete the removal.

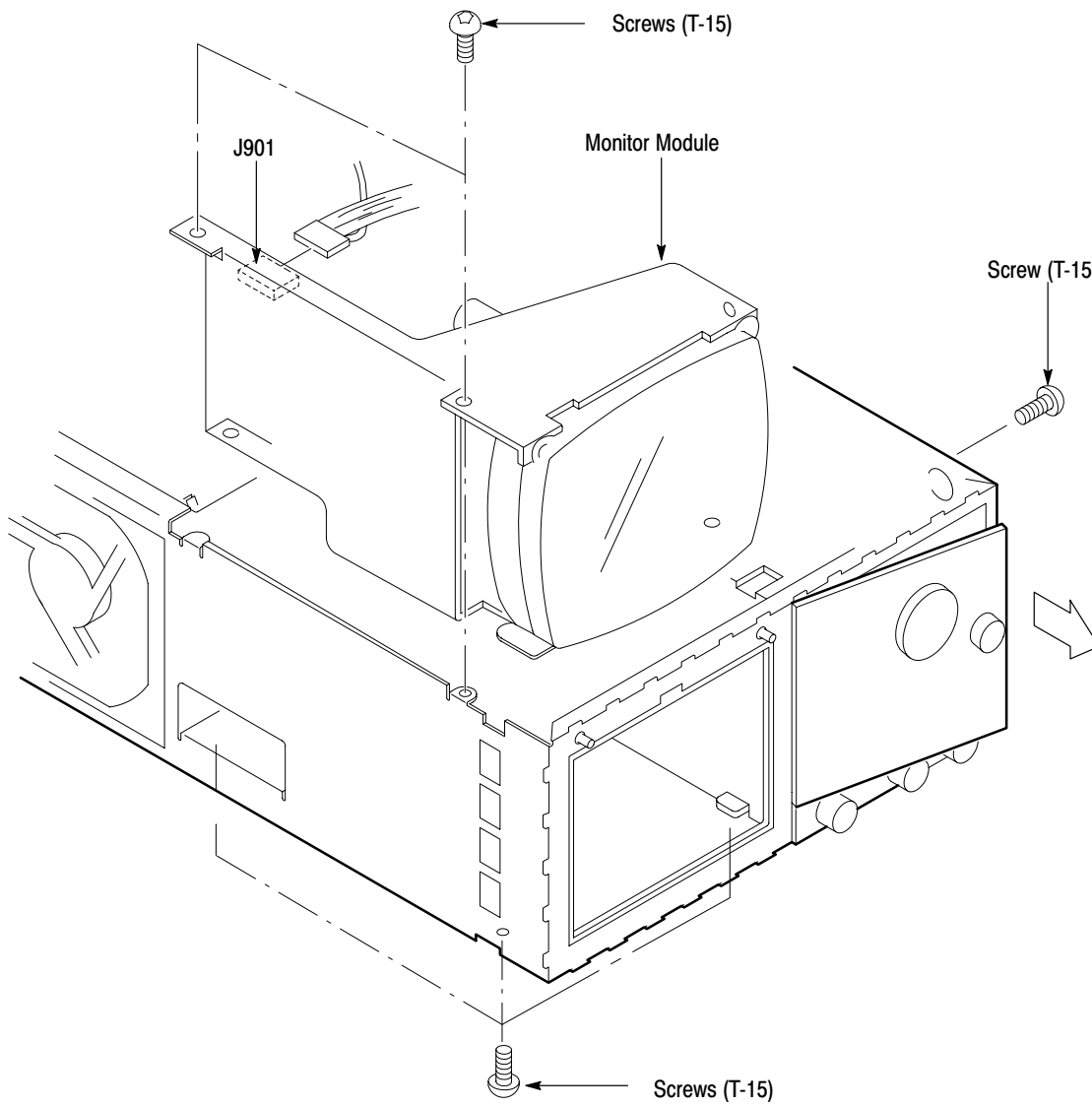

Figure 6-20: Monitor Module Removal

5. *Remove CRT frame:* Grasp the upper part of the CRT frame and take it out as shown in Figure 6-21.

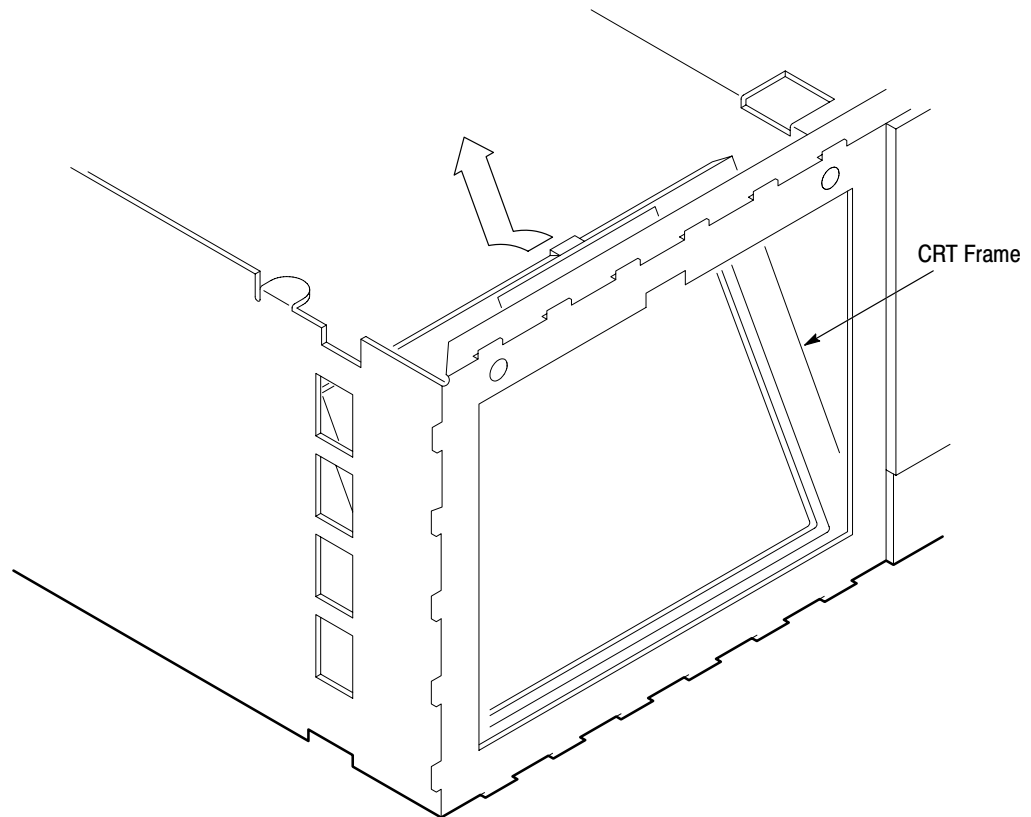

Figure 6-21: CRT Frame Removal

6. Reinstallation:

- a.** Grasp the upper part of the CRT frame, align the notch of the chassis with the protrusion of the CRT frame, and place the CRT frame in the chassis.
- b.** Install the monitor module by doing substeps 4a–4d in reverse order.

Circuit Boards

This procedure describes how to remove the following circuit boards:

- A6 CPU Board
 - A21 Control Board
 - A10 Synthesizer Board
 - For Option 02: A31 Control Board
 - For Option 03: A9 ECL Digital Data Out Board
 - For Option 04: A25 TTL Digital Data Out Board
 - For Option 09: A7 Floating Point Processor Board
1. *Assemble equipment and locate modules to be removed:* No tools are needed; however, the maintenance kit includes an ejector that is useful in removing circuit boards from the chassis. Locate the modules to be removed in the locator diagram, *Internal Modules*, in Figure 6-4.
 2. *Remove the rear shield cover:* Do the procedure, *Rear Shield Cover*, on page 6-33.
 3. *Orient instrument:* Set the AWG2021 with the left side down on the work surface and the top facing you.
 4. *Remove board support:* Remove the board support upward while pushing its hook to the inside.
 5. *Remove A6 CPU board:*



CAUTION. *To avoid permanent loss of waveform files, note the following: A lithium battery which maintains the nonvolatile memory when power is off is located on the A5 Backplane board. The nonvolatile memory that contains the waveforms and their setup parameter data is located on the A6 CPU board. Removing either board will cause the waveform files, sequence files, and autostep files in nonvolatile memory to be permanently lost. Before removing either the A6 CPU board or the A5 Backplane board, save the waveform files, sequence files, and autostep files in the instrument nonvolatile memory to a floppy disk. Then, after reinstalling the board(s), reload the files into nonvolatile memory.*

- a. Disconnect the ribbon interconnect cable at J50 and J64 on the A6 CPU board (see Figure 6-22).
- b. Disconnect the flat cable at J75 on the A6 CPU board. Remove the flat cable as shown in Figure 6-22.
- c. Grasp the upper part of the A6 CPU board, and pull upward to remove it.

- 6. Remove A21 Control board:**
 - a.** Disconnect the interconnect cable at J121 on the A21 Control board (see Figure 6–22).
 - b.** Disconnect the interconnect cables at J120 and J280 on the A21 Control board.
 - c.** Disconnect the interconnect cable at J100 on the A3 Analog board.
 - d.** For the instrument with Option 03, disconnect the flat cable at J4 on the A21 Control board.
 - e.** Grasp the A21 Control board and pull upward to remove them.
- 7. Remove A10 Synthesizer board:**
 - a.** Disconnect the interconnect cables at J280 on the A21 Control board (see Figure 6–22).
 - b.** Disconnect the interconnect cable at J201 and J750 on the A10 Synthesizer board.
 - c.** Disconnect the interconnect cables at J200 on the A10 Synthesizer board.
 - d.** For instruments with Option 02, disconnect the interconnect cables at J210 and J211 on the A10 Synthesizer board.
 - e.** Grasp the upper part of the A10 Synthesizer board, and pull upward to remove it.
- 8. Remove A31 Control board (Option 02):** The option adds the A31 Control board in the fourth slot from the top.
 - a.** Disconnect the interconnect cables at J120, J121, and J280 on the A21 Control board (see Figure 6–22).
 - b.** Disconnect the interconnect cable at J121 on the A31 Control board.
 - c.** Disconnect the interconnect cables at J120 and J280 on the A31 Control board.
 - d.** Disconnect the interconnect cable at J100 on the A23 Analog board.
 - e.** Grasp the A31 Control board, and pull upward to remove the boards.
- 9. Remove A9 Digital Data Out board (Option 03):** The option adds the A9 Digital Data Out board in the fourth slot from the top.
 - a.** Disconnect the interconnect cables at J120, J121, and J280 on the A21 Control board (see Figure 6–22).

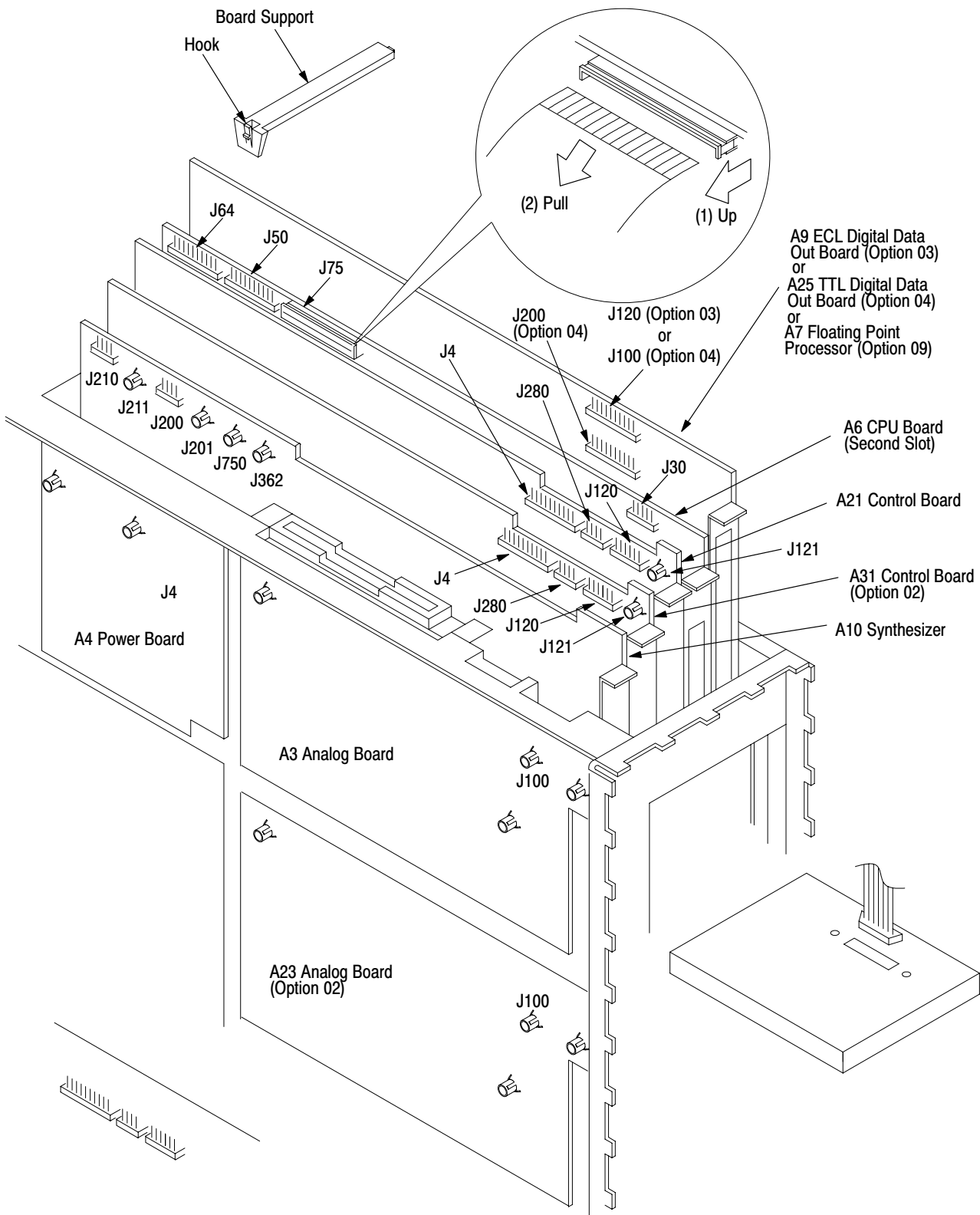

Figure 6-22: Board Removal

A5 Backplane Board



CAUTION. To avoid permanent loss of waveform files, note the following: A lithium battery which maintains the nonvolatile memory when power is off is located on the A5 Backplane board. The nonvolatile memory that contains the waveforms and their setup parameter data is located on the A6 CPU board. Removing either board will cause the waveform files, sequence files, and autostep files in nonvolatile memory to be permanently lost. Before removing either the A6 CPU board or the A5 Backplane board, save the waveform files, sequence files, and autostep files in the instrument nonvolatile memory to a floppy disk. Then, after reinstalling the board(s), reload the files into nonvolatile memory.

1. *Assemble equipment and locate modules to be removed:*
 - a. You will need a screwdriver with a size T-15 Torx® tip and a flat-bladed screwdriver to do this procedure.
 - b. Locate the modules to be removed in the locator diagram, *Internal Modules*, in Figure 6-4.
2. *Orient instrument:* Set the AWG2021 with the left side down on the work surface and the top facing you.
3. *Remove all boards:* Do the procedure, *Circuit Boards*, on page 6-42.
4. *Remove A5 Backplane board:*
 - a. Remove the five screws and a nut securing the shield cover (see Figure 6-23).
 - b. Grasp the shield cover, and take it out.
 - c. Disconnect the ribbon interconnect cables at J100 on the A4 Power board and at J410 on the A3 Analog board (see Figure 6-12 and Figure 6-13).
 - d. Disconnect the ribbon interconnect cable at J10 on the A5 Backplane board.
 - e. Disconnect the flat cable at J6 on the A5 Backplane board.
 - f. Remove the remaining four screws securing the A5 Backplane board to the chassis.
 - g. Using a flat-bladed screwdriver, release the four hooks of the circuit board support that holds the A5 Backplane board, lift the A5 Backplane board sideways, and then take it out.

5. Reinstallation:

- a. *Install the A5 Backplane board:* Do substeps 4a–4g in reverse order to install the board.
- b. *Install the other boards:* Do the procedure, *Circuit Boards*, on page 6–42, in reverse order, reversing the items in each step.

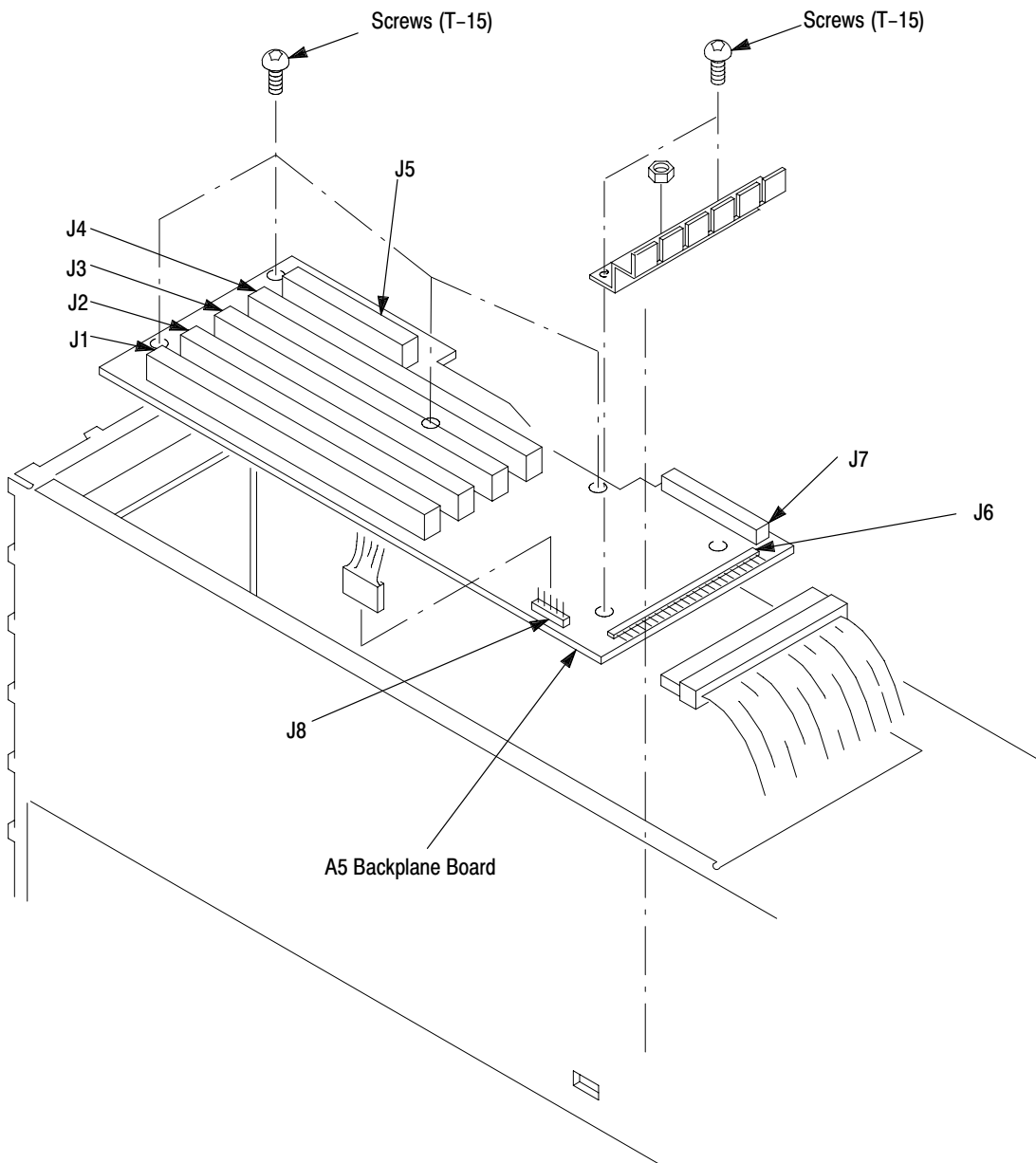
**Figure 6-23: A5 Backplane Board Removal**

Lithium Battery



WARNING. To avoid the risk of fire or explosion, install a new battery that has the same part number as listed in section 10, Mechanical Parts List, for a replacement battery.

To avoid the risk of fire or explosion, do not recharge, rapidly discharge, or disassemble the battery, heat it above 100° C, or incinerate it.

Dispose of used batteries promptly. Small quantities of used batteries may be disposed of in normal refuse. Keep lithium batteries away from children.

1. *Assemble equipment and locate modules to be removed:*
 - a. You will need a soldering iron to do this procedure.
 - b. You will also need a replacement lithium battery having the part number listed in section 10, *Mechanical Parts List*.
 - c. Locate the battery to be removed in the locator diagram, *Internal Modules*, in Figure 6-4.
2. *Remove A5 Backplane board:* Do the *A5 Backplane Board* procedure on page 6-46.
3. *Orient board:* Set the A5 Backplane board on an insulating surface.
4. *Remove used battery:*
 - a. Unsolder the tabs at the ends of the battery, taking care not to heat the battery (see Figure 6-24).
 - b. Grasp the battery, and lift it away from the board.
5. *Install new battery:*
 - a. Place the new battery on the board with the negative tab of the battery closest to the board edge connector.
 - b. Solder the tabs to the board.

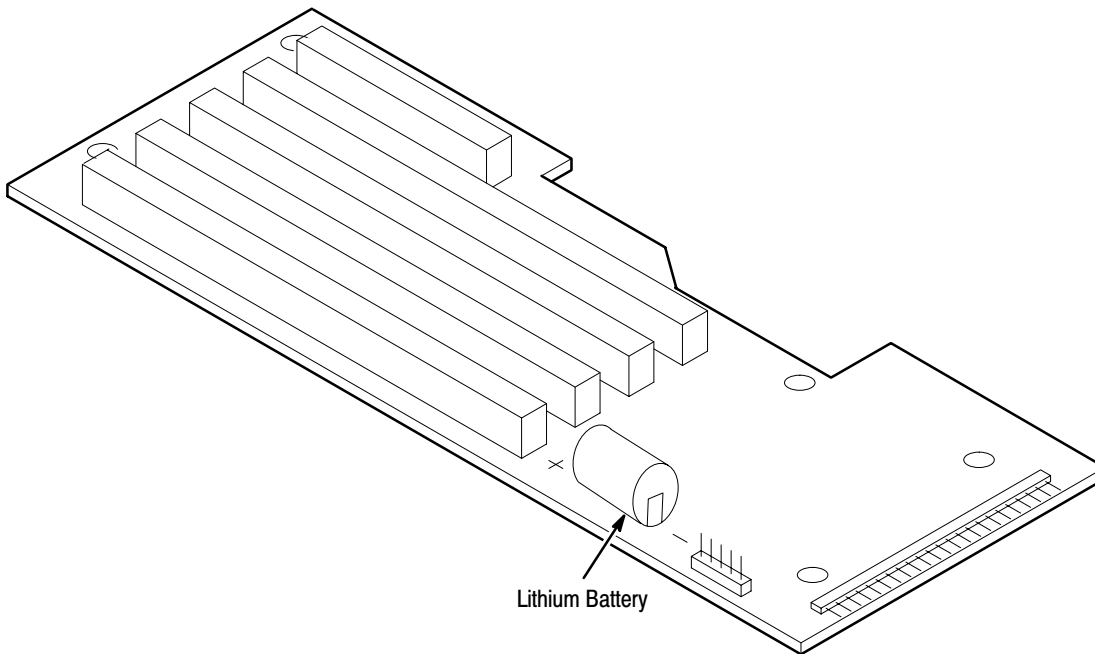

Figure 6-24: Battery Location on the A5 Backplane Board

Floppy-disk Drive Module

1. *Assemble equipment and locate modules to be removed:*
 - a. You will need a screwdriver with a size T-10 Torx® tip and a size #1 Phillips tip to do this procedure.
 - b. Locate the modules to be removed in the locator diagram, *Internal Modules*, in Figure 6-4.
2. *Remove rear shield cover:* Do the *Rear Shield Cover* procedure on page 6-33.
3. *Remove A3 Analog board:* Do the *A3 Analog Board* procedure on page 6-27, removing only the A3 Analog board.
4. *Orient instrument:* Set the AWG2021 with the left side down on the work surface and the bottom facing you.
5. *Remove all circuit boards:* Do the procedure, *Circuit Boards*, on page 6-42.

6. Remove floppy-disk drive module:

- a.** Using a screwdriver with a size T-10 Torx® tip, remove the six screws securing the floppy-disk drive cover to the chassis (see Figure 6-25).
- b.** Disconnect the flat cable of the floppy disk drive.
- c.** Using a screwdriver with a size #1 Phillips tip, remove the three screws securing the floppy-disk drive to the bracket.
- d.** Using a screwdriver with a size #1 Phillips tip, remove the screws securing the spacer to floppy-disk drive.
- e.** Grasp the upper part of the floppy-disk drive, and pull it upward to remove it.

7. Reinstallation:

- a.** *Install floppy-disk drive module:* Do substeps 6a–6e in reverse order.
- b.** *Install circuit boards:* Do the procedure, *Circuit Boards*, on page 6-42, in reverse order.
- c.** *Install A3 Analog board:* Do the part on removing the A3 Analog board in *A4 Power Board, A3 Analog Board, and A23 Analog Board* on page 6-27 in reverse order. This completes the reinstallation.

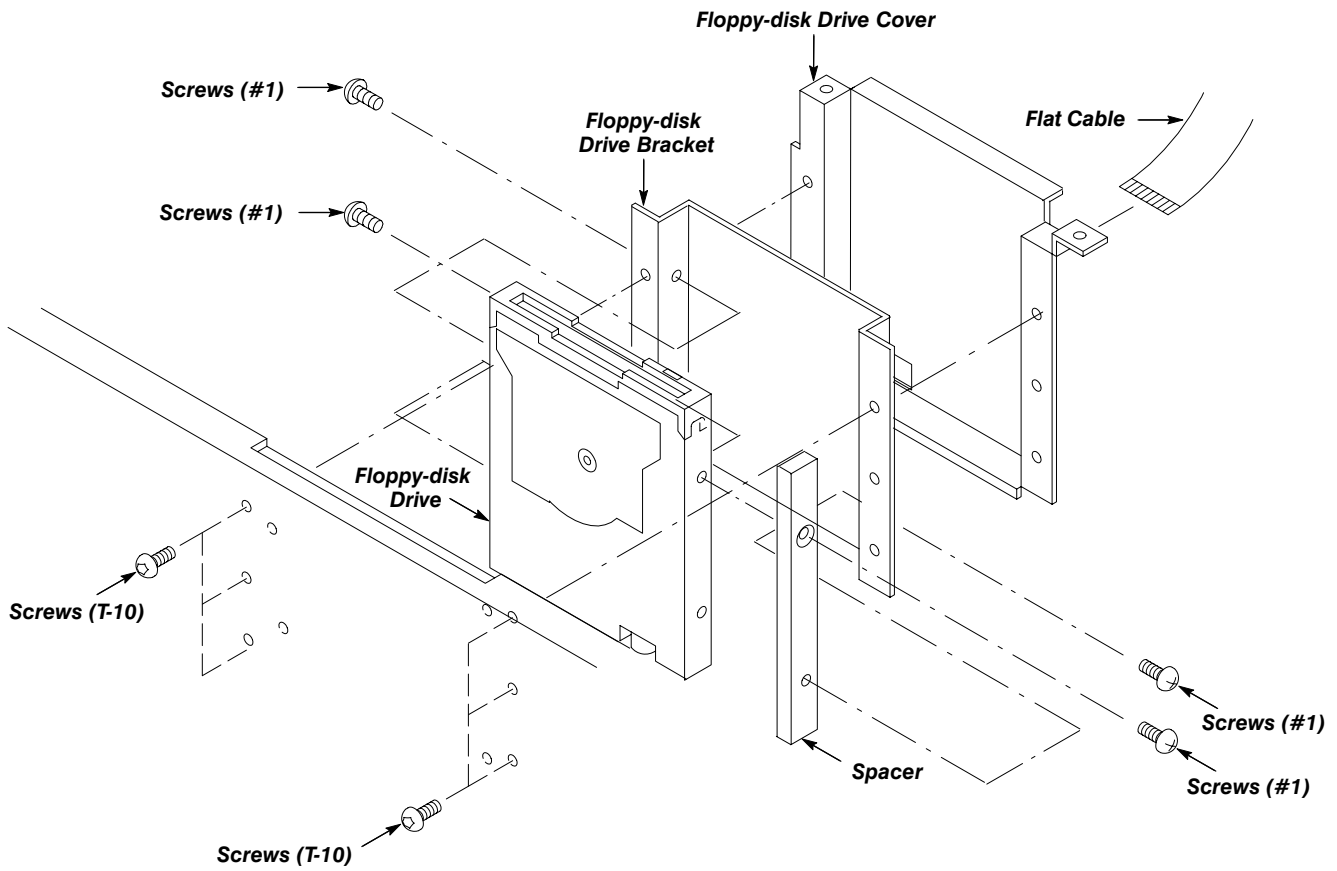

Figure 6-25: Floppy-disk Drive Module Removal

Troubleshooting

This subsection contains information and procedures designed to isolate faulty modules in the AWG2021 Arbitrary Waveform Generator. If these procedures indicate a module needs to be replaced, follow the *Removal and Installation Procedures* in the preceding subsection.

After Repair Adjustment

After replacing a module, do the adjustments in section 5, *Adjustment Procedures* (page 5–1).

Troubleshooting Procedures

The troubleshooting procedures in this subsection consist of these flowcharts.

- Figure 6–27: Primary Troubleshooting Procedure
- Figure 6–28: Troubleshooting Procedure 1 — Power Supply Module
- Figure 6–33: Troubleshooting Procedure 2 — A6 CPU Board or Front-panel Module
- Figure 6–35: Troubleshooting Procedure 3 — Monitor Module
- Figure 6–39: Troubleshooting Procedure 4 — Module Isolation

To use these procedures, begin with the Primary Troubleshooting Procedure. It prompts you to check various indications of AWG2021 functionality and directs you to the other troubleshooting procedures.

AWG2021 Diagnostics

The AWG2021 has internal diagnostics that verify circuit functionality. The AWG2021 automatically executes the internal diagnostics at power-on. You can also run the internal diagnostics by using the UTILITY menu. See *Checking Diagnostics Tests* on page 6–54. The two methods of running the internal diagnostics routine are the same, but the power-on method does a less extensive memory check.

If the internal diagnostics indicate a test in the internal diagnostics failed, use the troubleshooting procedures in this subsection to determine which module to replace.

Checking Diagnostics Tests

Prerequisites. Power on the AWG2021 and allow a 20-minute warmup before doing this procedure.

1. Push the **UTILITY**→**Diag/Cal**→**Diagnostics**
2. Select **All** with the general purpose knob.
3. Select **Execute** from the side menu. This executes all the diagnostics automatically. As each test finishes, the result is displayed on the screen.
4. Check the diagnostic test results. If any test failed, go to *Troubleshooting Procedure 4 — Module Isolation* on page 6–64. The table in the flowchart shows which module is related to each diagnostic test. If the tests pass but there is still a problem, go to the *Primary Troubleshooting Procedure* on page 6–55.

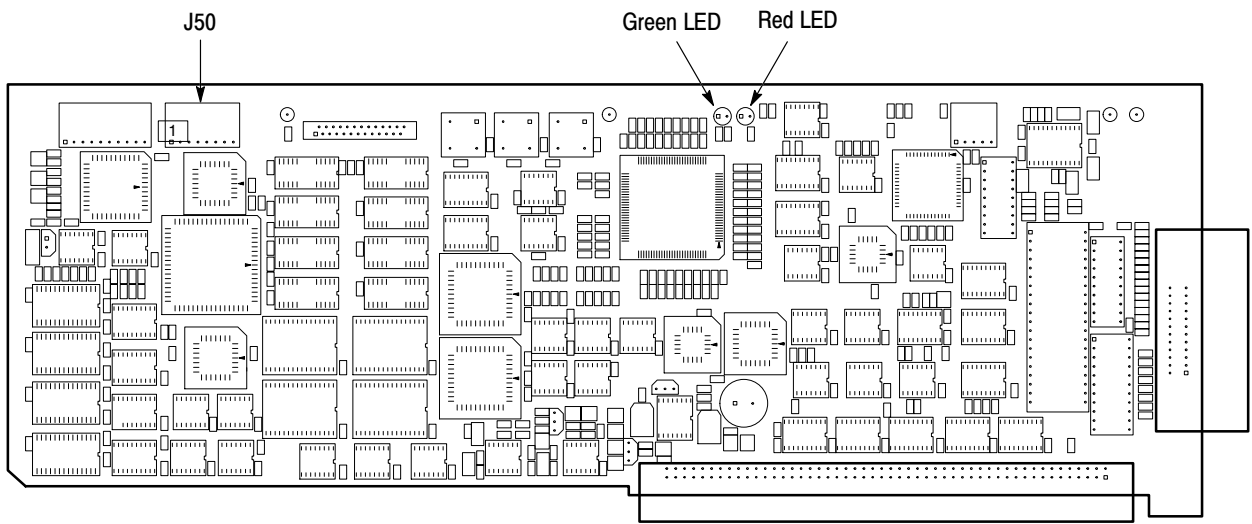

Figure 6-26: A6 CPU Board

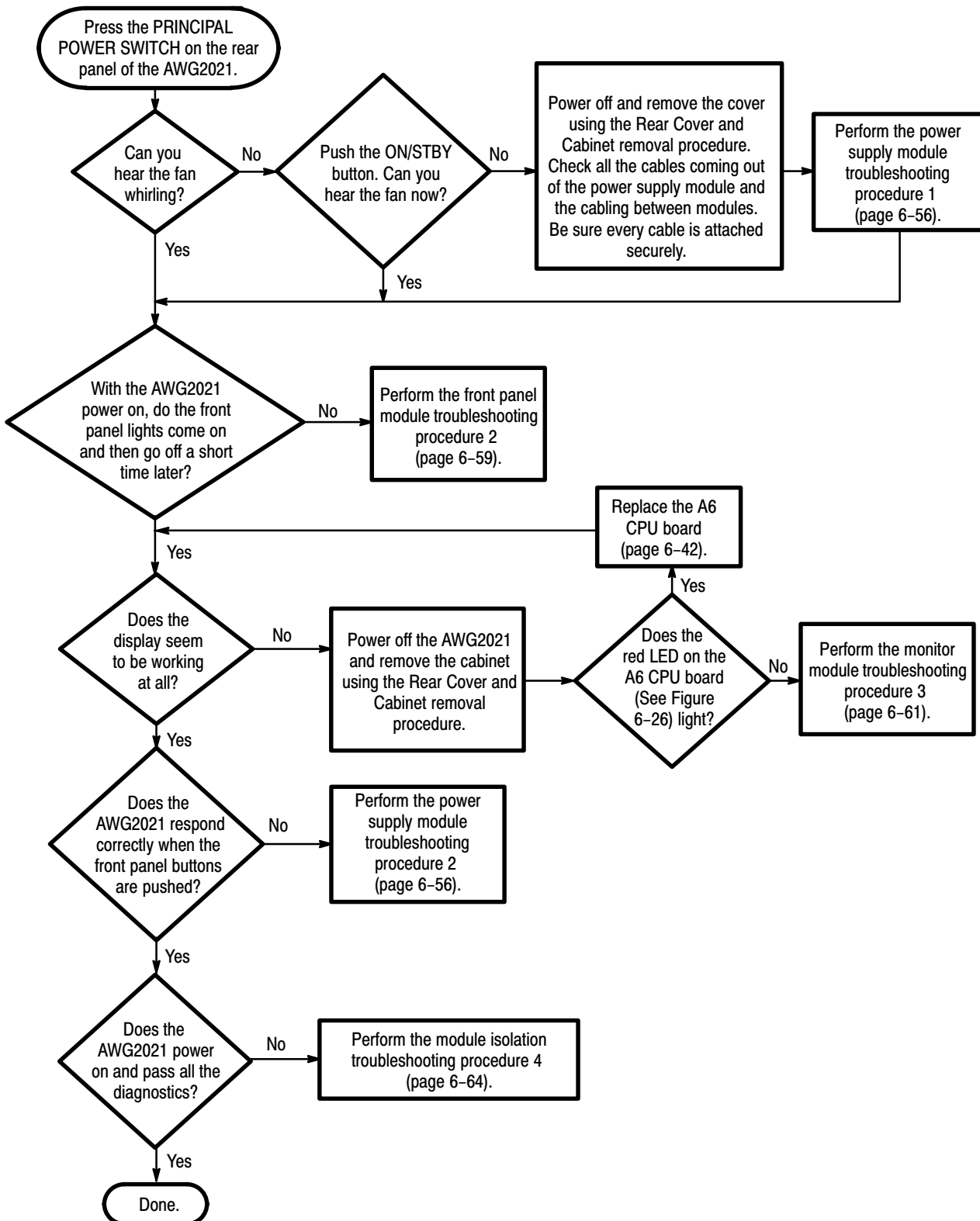

Figure 6-27: Primary Troubleshooting Procedure

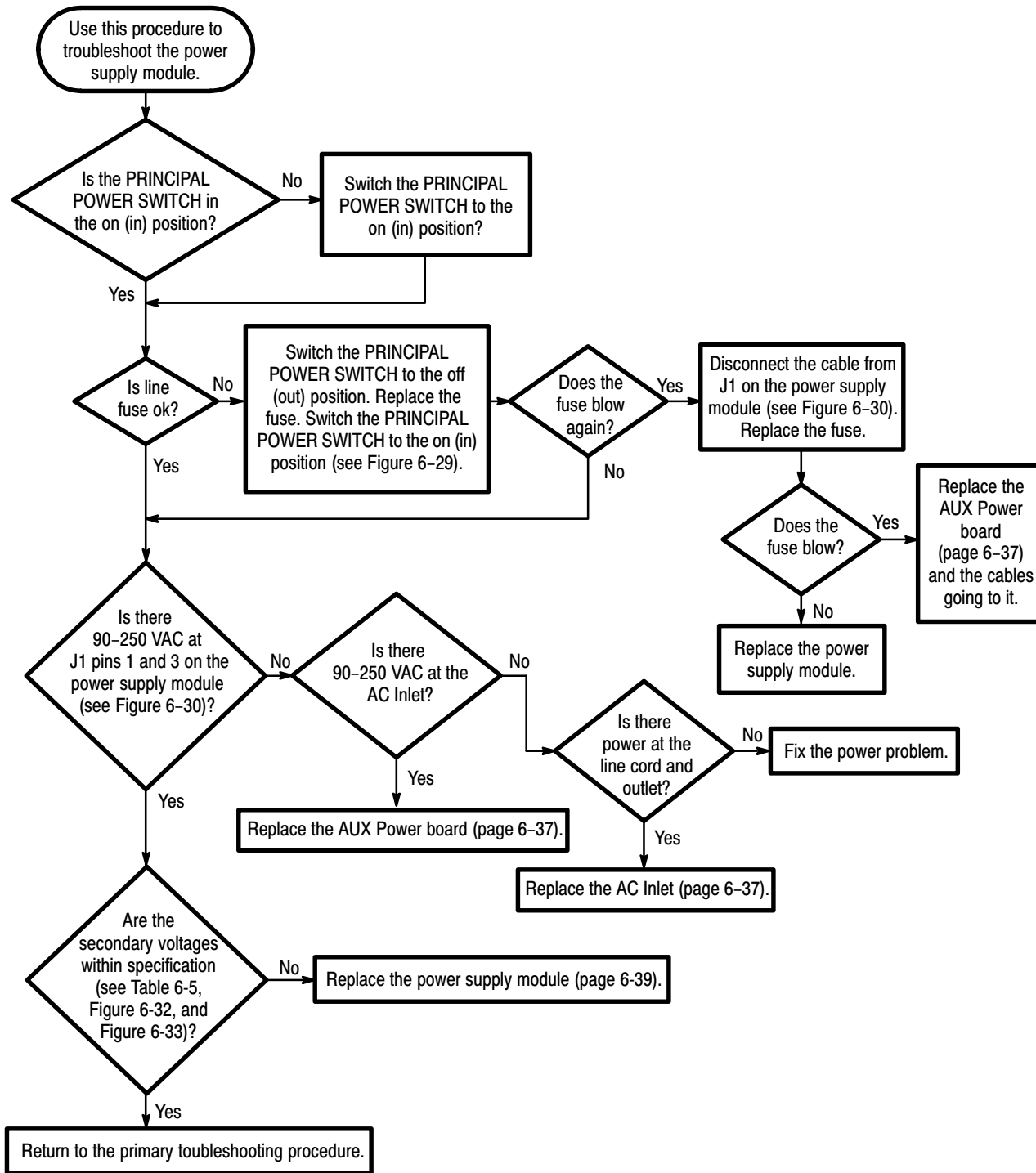

Figure 6-28: Troubleshooting Procedure 1 — Power Supply Module

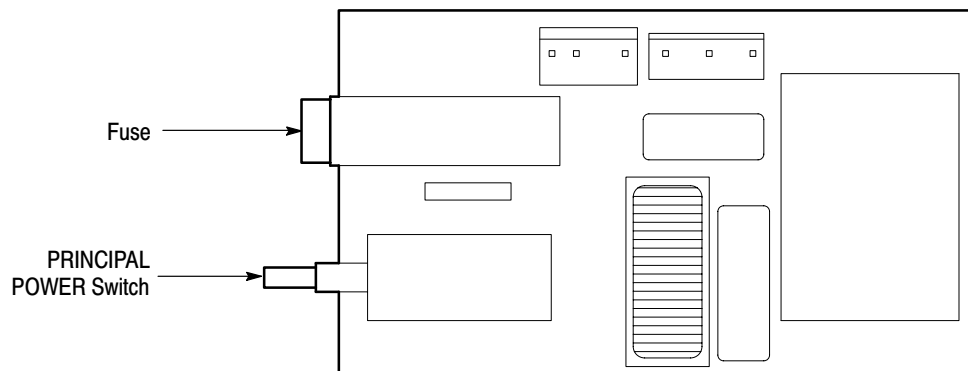

Figure 6-29: AUX Power Board

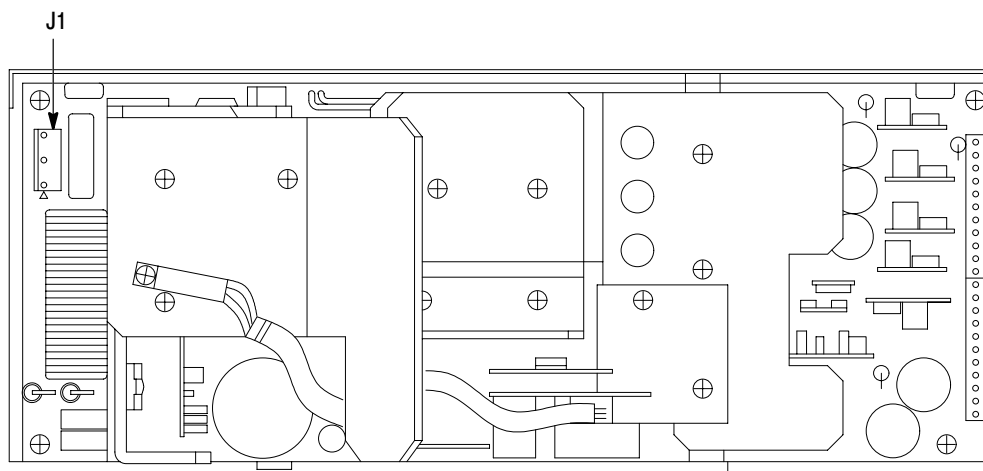

Figure 6-30: Power Supply Module

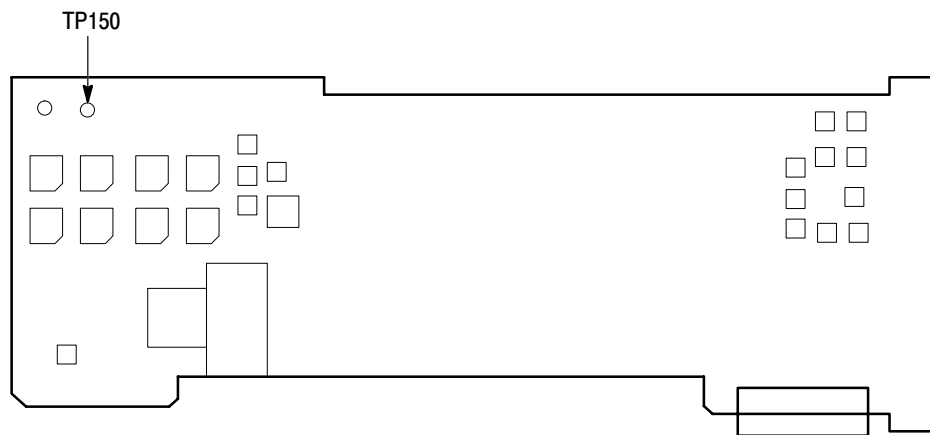

Figure 6-31: A10 Synthesizer Board

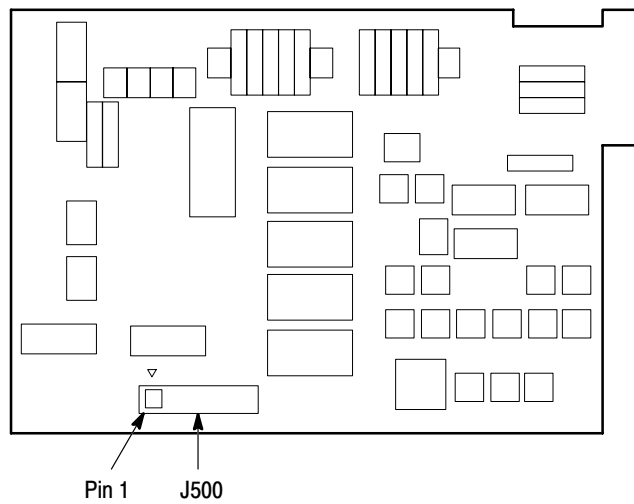

Figure 6-32: A3/A23 Analog Board

Table 6-5: Secondary Power Supply Voltages

Supply	Test Point	Minimum Level	Maximum Level
+15.0 V	A3/A23 J500 Pin 3	+14.25 V	+15.75 V
-15.0 V	A3/A23 J500 Pin 6	-14.25 V	-15.75 V
+5.0 V	A3/A23 J500 Pin 9	+4.75 V	+5.25 V
-5.0 V	A3/A23 J500 Pin 10	-4.75 V	-5.25 V
-2.0 V	A10 TP150	-1.85 V	-1.90 V

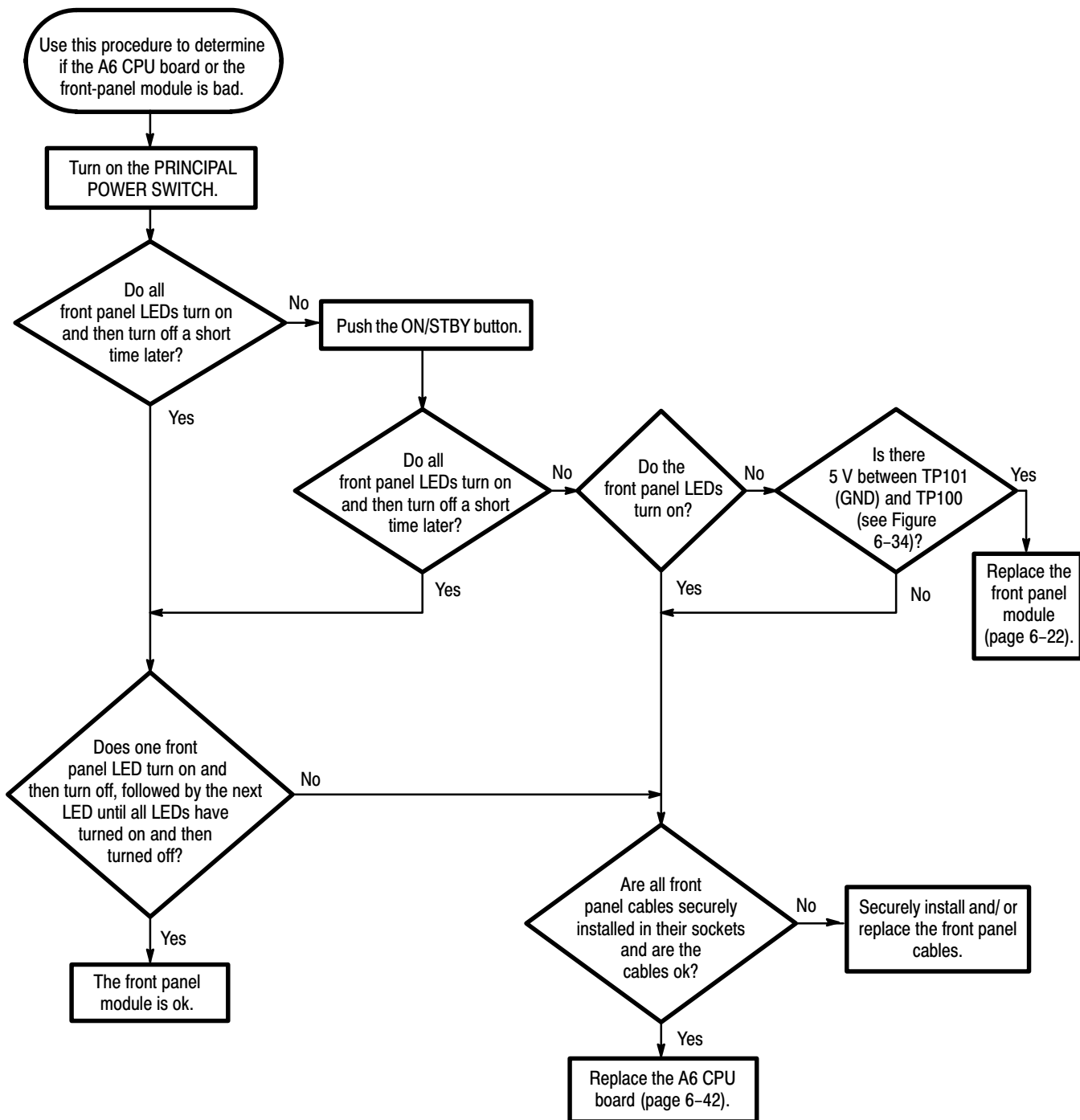

Figure 6-33: Troubleshooting Procedure 2 — A6 CPU Board or Front-panel Module

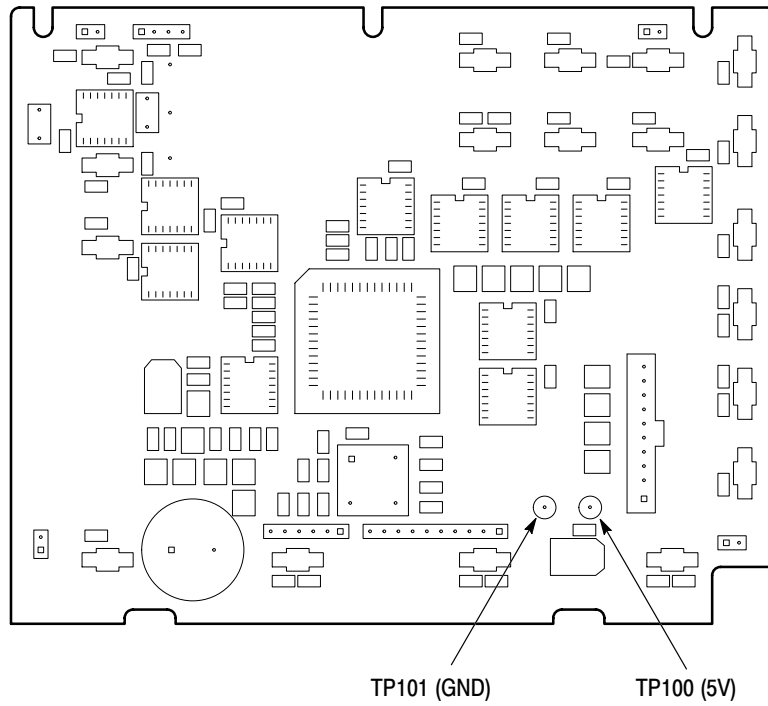

Figure 6-34: Key Board

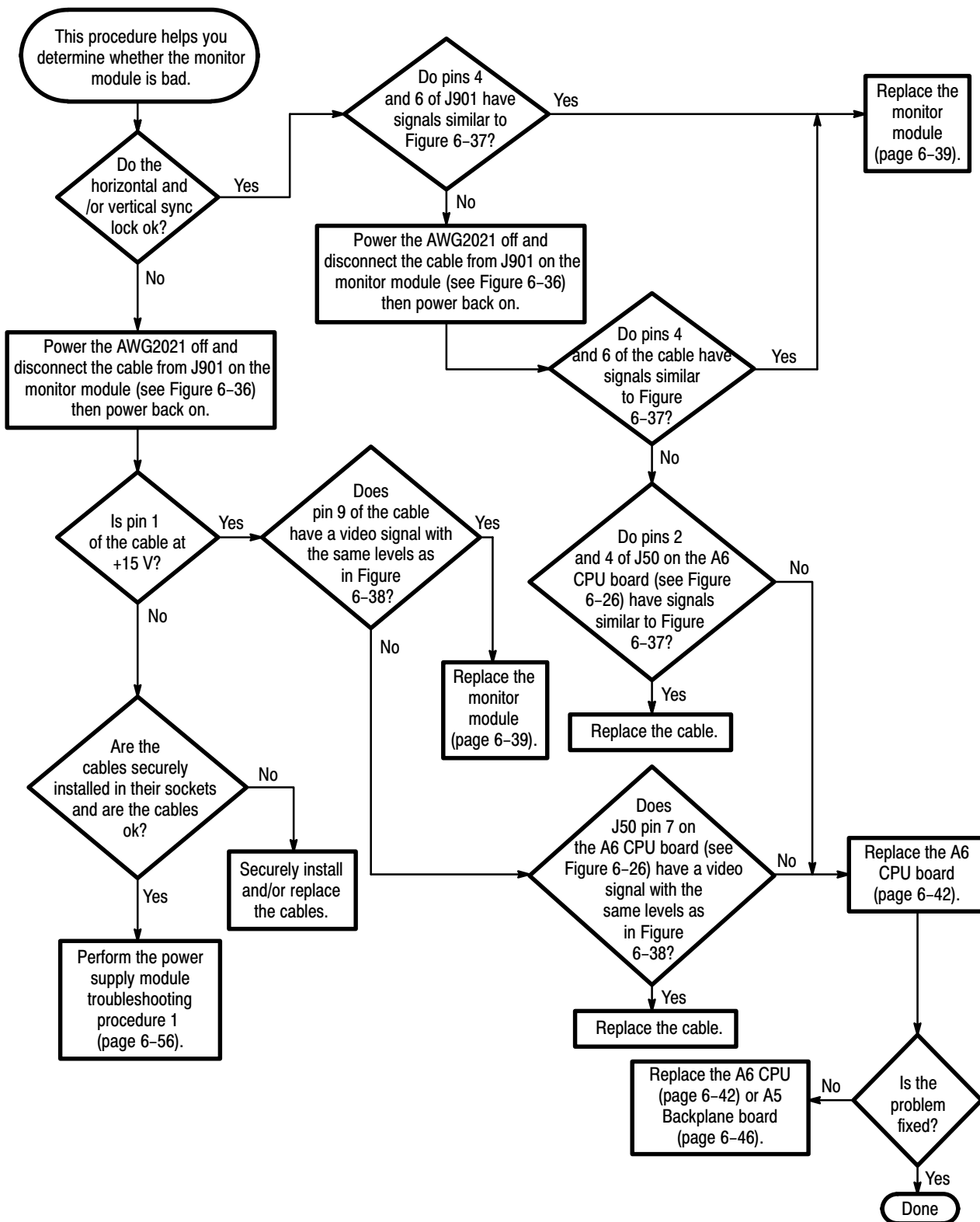

Figure 6-35: Troubleshooting Procedure 3 — Monitor Module

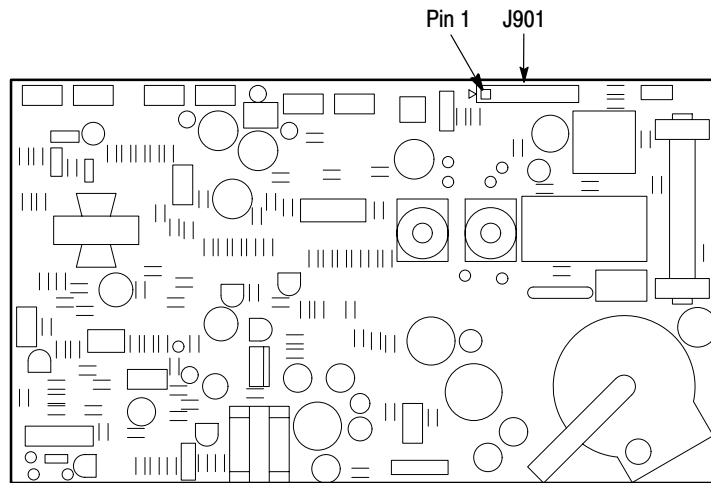

Figure 6-36: Monitor Module

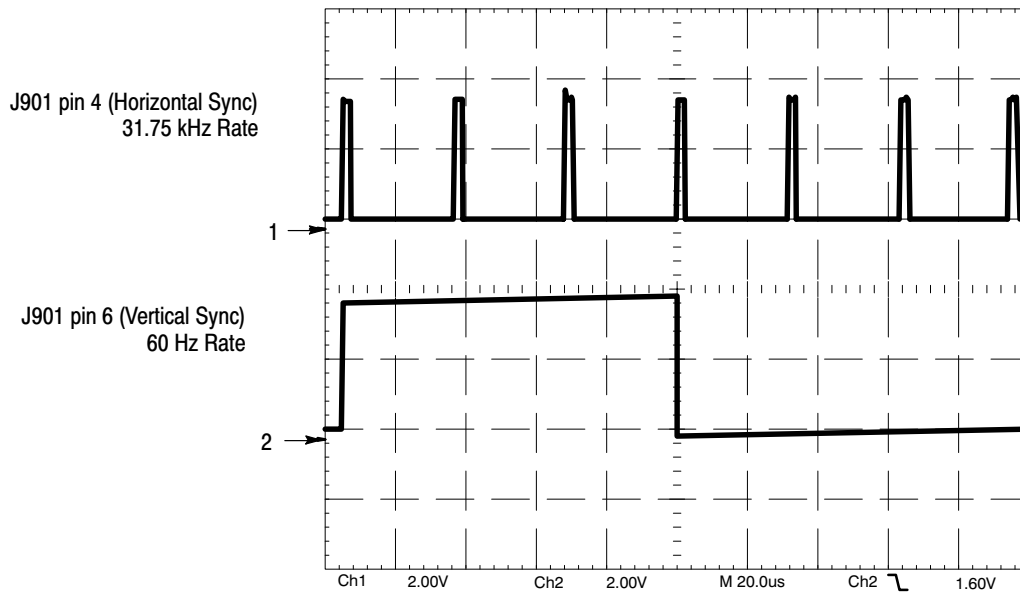

Figure 6-37: Horizontal and Vertical Sync Signals

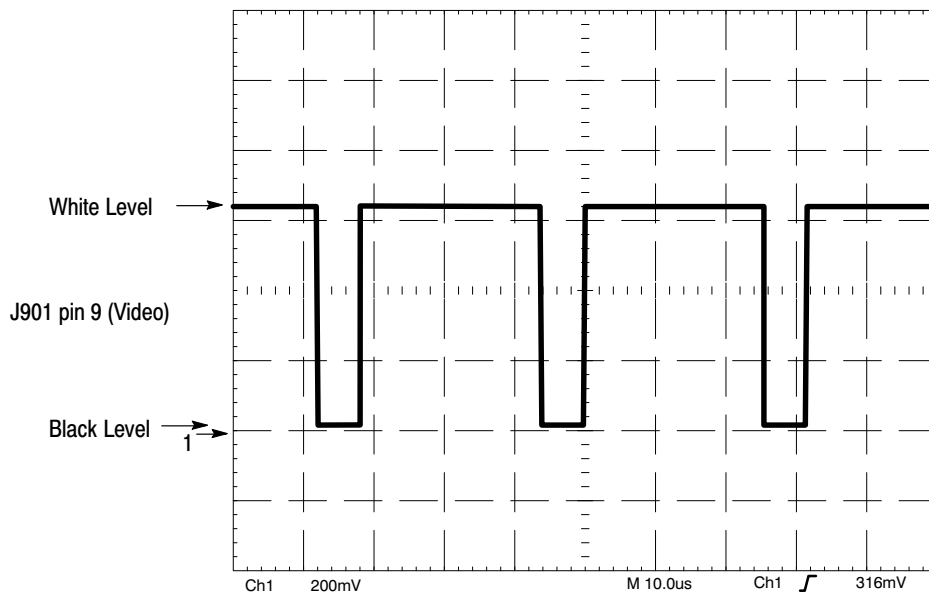

Figure 6-38: A Video Signal with White and Black Levels

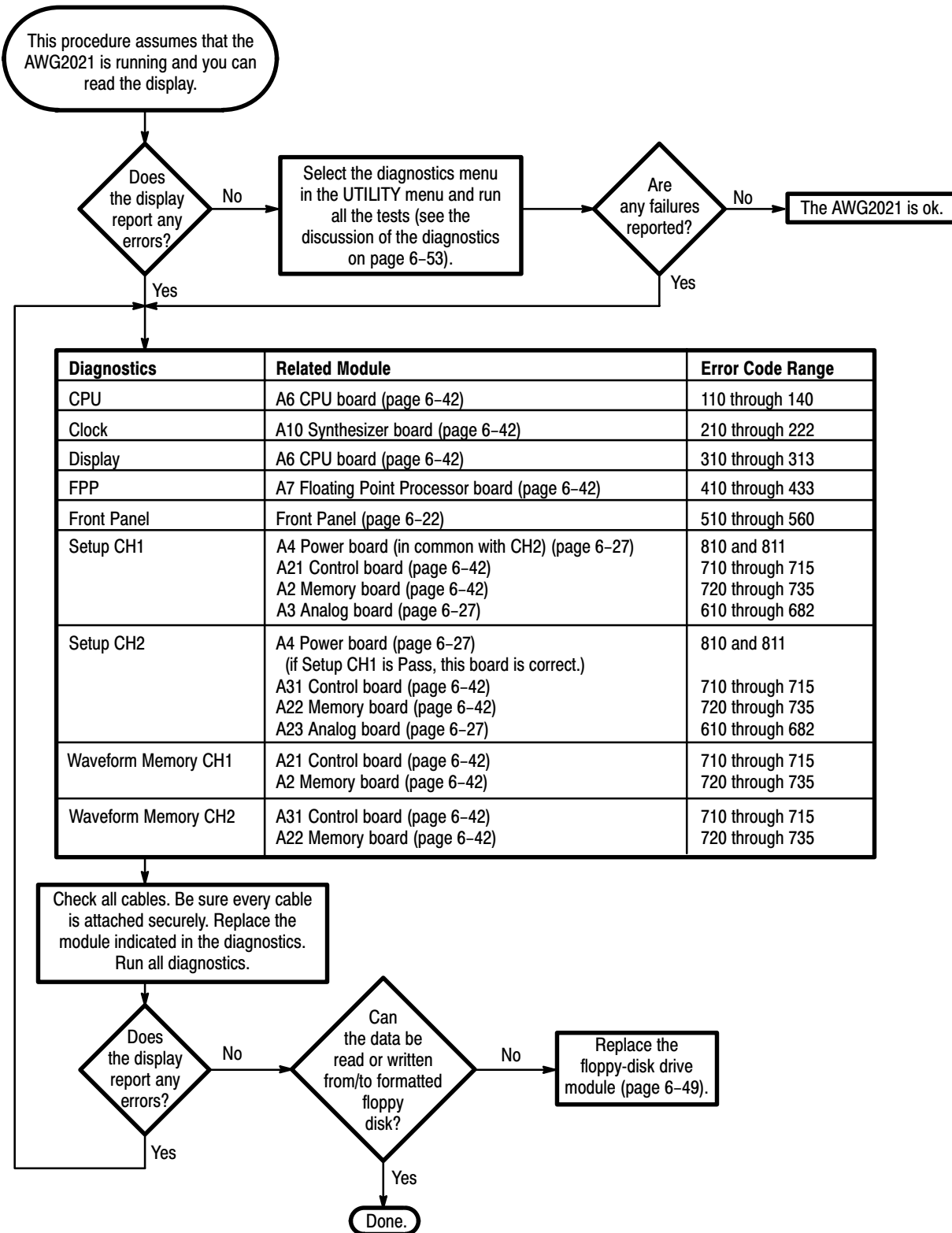

Figure 6-39: Troubleshooting Procedure 4 — Module Isolation

Options

Options and Accessories

This section describes the various options as well as the standard and optional accessories that are available for the AWG2021 Arbitrary Waveform Generator.

List of Options

The following options are available:

- *Option 02* adds a CH2 output. Refer to page 7–2 for details.
- *Option 03* makes ECL-level digital waveform data available at the rear panel. See note below; then refer to page 7–2 for details.
- *Option 04* makes TTL-level digital waveform data available at the rear panel. See note below; then refer to page 7–11 for details.
- *Option 09* provides increased internal calculation speed and two additional editors: an FFT editor and a convolution editor. See note below; then refer to page 7–17 for details.
- *Option 1R* ships the waveform generator configured for installation in an instrument rack. Refer to page 7–17 for details.
- *Option 1S* adds the WaveWriter S3FT400.
- *Option 95* ships with a test result report.
- *Option A1–A5* changes the standard power cord to one of five alternate power cord configurations. Refer to page 7–2 for details.
- *Option B1* adds the service manual and the Performance Check/Adjustment disk.

NOTE. An AWG2021 cannot be equipped with *Option 03*, *Option 04* and *Option 09*. Select either *Option 03*, *Option 04* or *Option 09*.

Options A1–A5

In place of the standard North American, 110 V, 60 Hz power cord, Tektronix ships any of five alternate power cord configurations with the waveform generator. See Table 7–1 for a list of the power cord configurations.

Table 7–1: International Power Cords

Option	Power Cord
Option A1	Universal European — 220 V, 50 Hz
Option A2	United Kingdom — 240 V, 50 Hz
Option A3	Australian — 240 V, 50 Hz
Option A4	North American — 240 V, 60 Hz
Option A5	Switzerland — 220 V, 50 Hz

Option 02 Description

Option 02 adds a second output channel. The second output channel allows you to simultaneously output two different waveforms and to use arithmetic functions.

Option 03 Description

With Option 03, the waveform generator can provide the following digital signals at the rear panel output connector. This option cannot be installed with Option 04 or Option 09 .

Data Output The data (D0–D11) going to the internal D/A converter is buffered and routed to the output connector at the rear panel. When generating an analog waveform at the front panel, the waveform generator simultaneously outputs digital data at the rear panel connector. The output is differential ECL.

Clock Output The same clock that goes to the internal D/A converter is buffered and routed to the rear panel connector. The clock output is also differential ECL.

Figure 7–1 shows a block diagram of the Option 03 circuit.

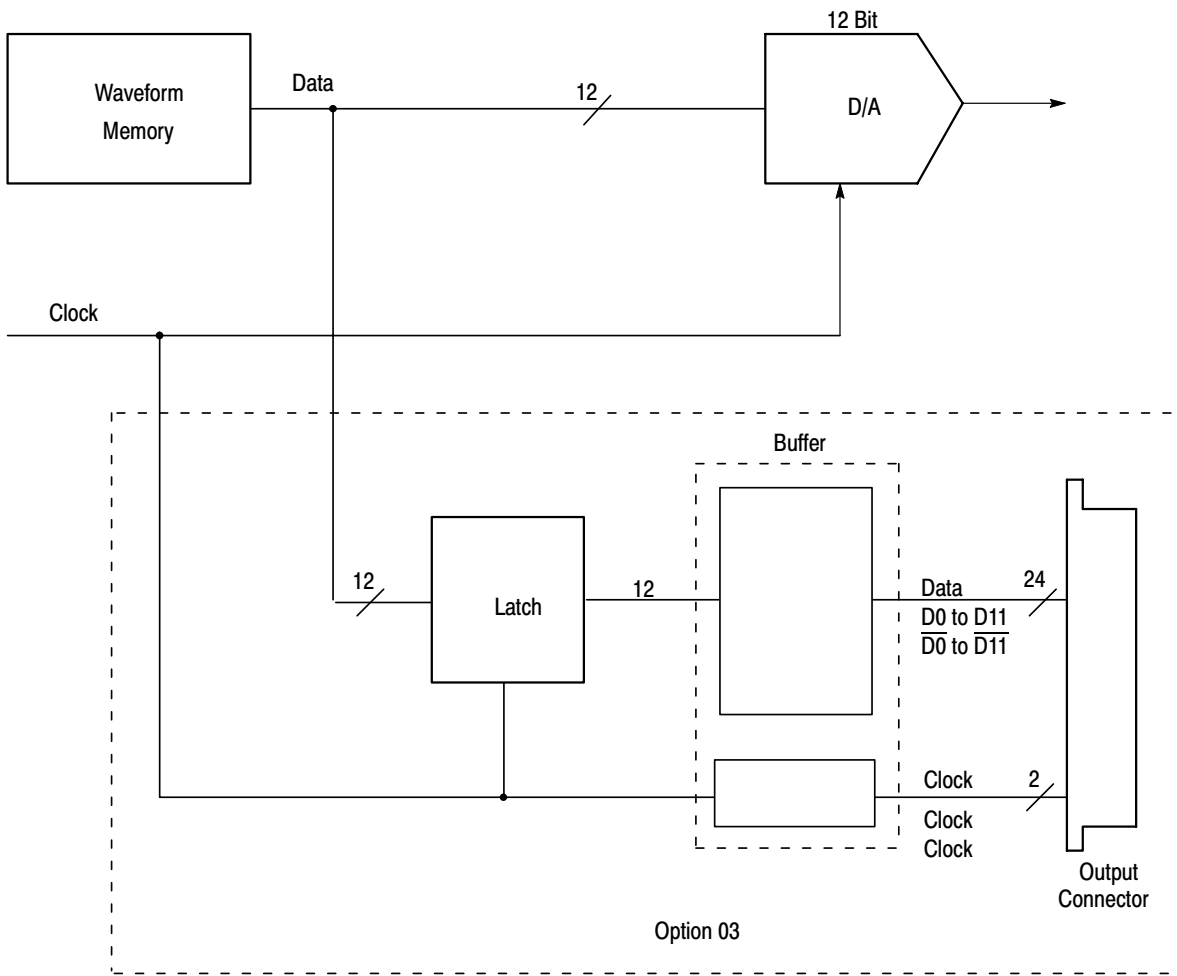

Figure 7-1: Option 03 Block Diagram

Output Connector Configuration

Figure 7–2 shows the shape of the output connector and its pin locations. Table 7–2 lists the output signal for each pin.

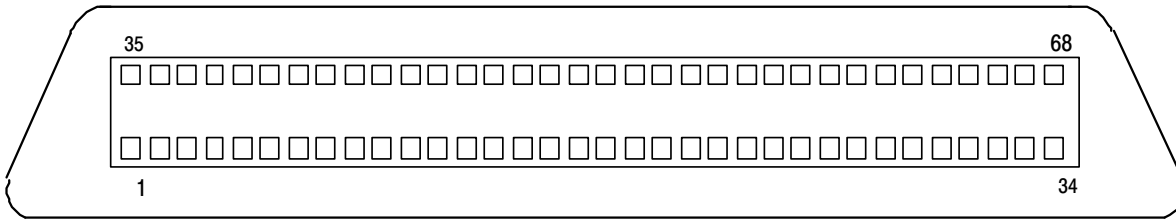

Figure 7–2: Option 03 Output Connector

Table 7–2: Option 03 Digital Output Signals

Pin Number	Signal	Pin Number	Signal
6	\sim CLOCK	39	CLOCK
14	\sim Data bit 0	47	Data bit 0
12	\sim Data bit 1	45	Data bit 1
10	\sim Data bit 2	43	Data bit 2
8	\sim Data bit 3	41	Data bit 3
16	\sim Data bit 4	49	Data bit 4
20	\sim Data bit 5	53	Data bit 5
22	\sim Data bit 6	55	Data bit 6
18	\sim Data bit 7	51	Data bit 7
30	\sim Data bit 8	63	Data bit 8
28	\sim Data bit 9	61	Data bit 9
26	\sim Data bit 10	59	Data bit 10
24	\sim Data bit 11	57	Data bit 11

Pins 4, 33, 34, 37, 67, and 68 have no internal connection.

All other pins are connected to chassis ground.

\sim indicates an active low signal.

Operation Operation when Option 03 is installed is basically the same as the standard AWG2021 operation. When a waveform is not being output, the waveform initial data can be output to the connector. At this time, the clock is not generated.

When waveform output begins, the clock is generated and the data is updated.

NOTE. During the hold-off period, when loading a new waveform into waveform memory and resetting the waveform memory, excess output is generated in the data clock (see Figure 7-3).

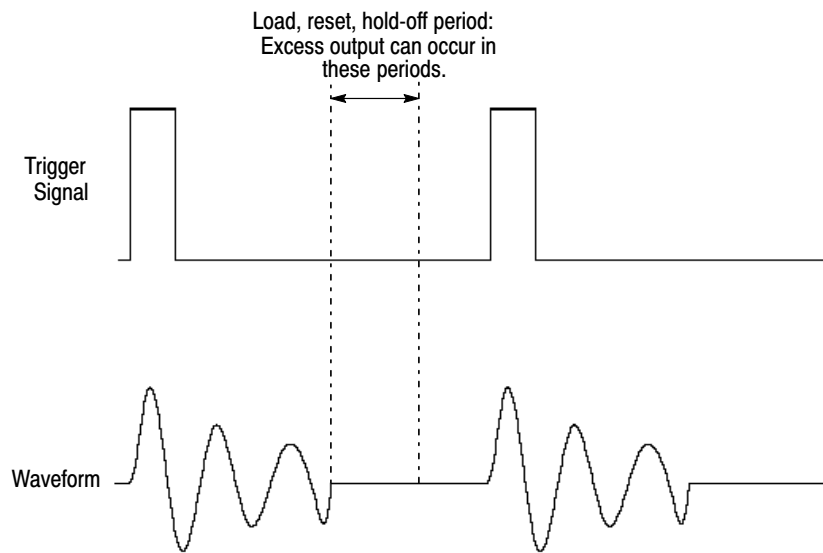

Figure 7-3: Generation of Excess Output

Output Circuit and Output Waveform

The ECL buffer (10E116) output is connected to the output connector. It must be terminated with a $50\ \Omega$ resistor at the receiving side (user side). If this termination resistor is missing, the signals do not appear at the output connector. The same is true for the clock output. See Figure 7-4.

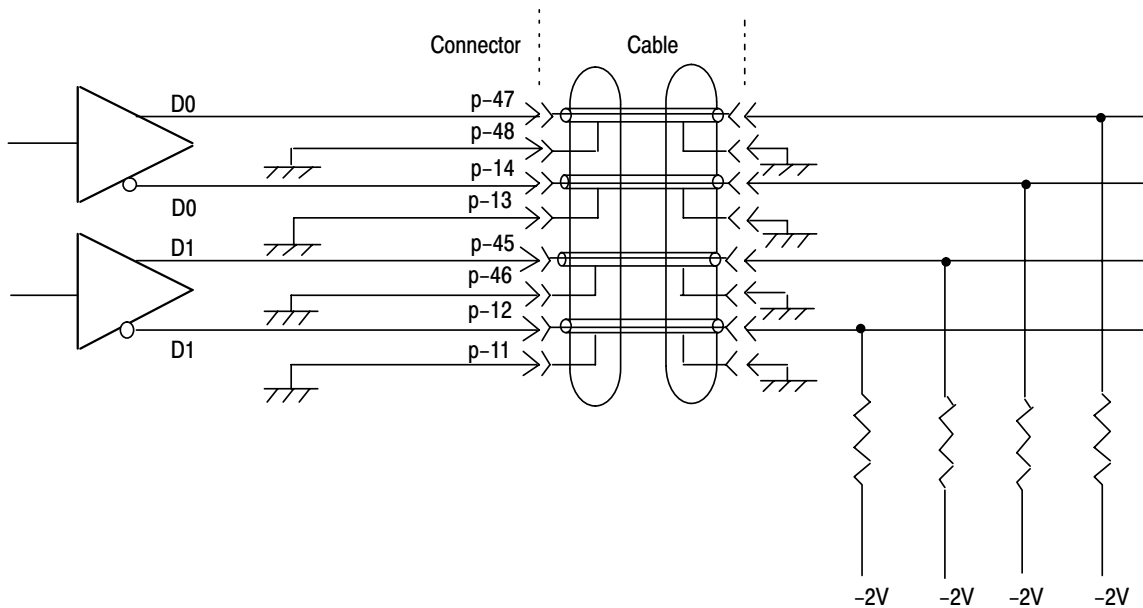

Figure 7-4: Output Circuit

The data output signal skew is held to 1 ns, maximum. The rise and fall times depend on characteristics of the buffer IC, but neither is greater than 1 ns. See Figure 7-5. Both of these maximum levels are the values without using cables. If a cable is used, these waveforms have transmission distortion.

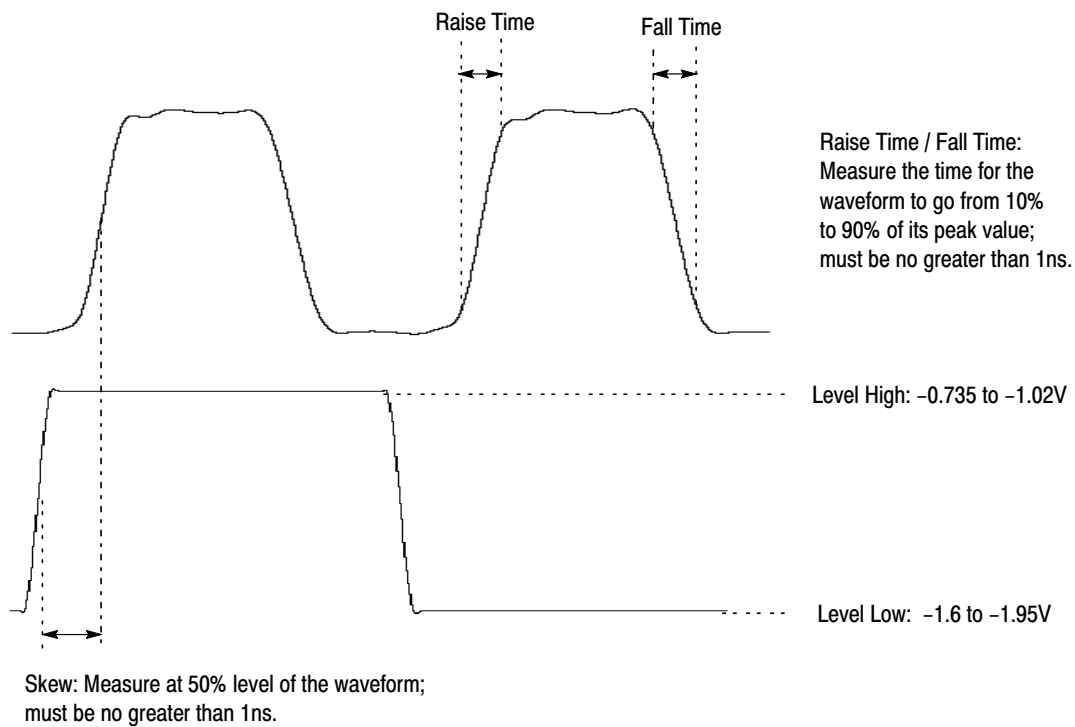

Figure 7-5: Output Waveform

Latch the data with a clock before using the waveform. Delay the clock appropriately with a delay line in order to reproduce the data reliably. See Figure 7-6.

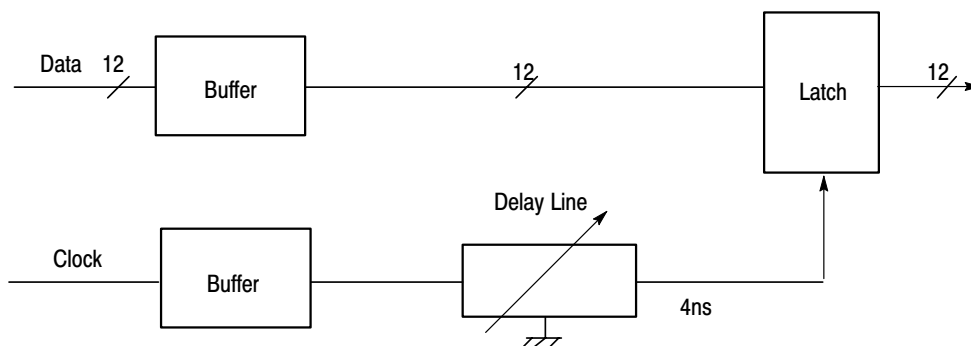

Figure 7-6: Data Latching

Application Suggestions

Cables. The cable connecting the AWG2021 rear panel output connectors and the user circuit is extremely critical for operation at the maximum clock frequency. Thus, follow these recommendations to obtain optimum performance:

- Use coaxial cables with a characteristic impedance of 50 Ω for all DATA and CLOCK lines.
- Keep cables as short as possible. The acceptable length depends on the characteristics of the coaxial cable used, but lengths under 1 meter are desirable.
- In order to minimize signal reflection, carefully dress the ends of the cables as described below:
 - *Make the section stripped of its outer covering as short as possible. Figure 7-7 shows the strip length of the coaxial cable.*
 - *Connect the external covering of the cable to the ground for the signals corresponding to each connector.*

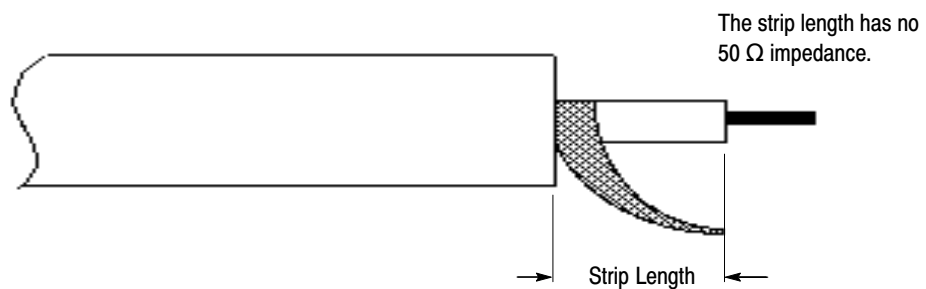

Figure 7-7: Coaxial Cable End Processing

Cable Examples. The AWG2021 with Option 03 comes with a digital data out cable as a standard accessory. The cable is one meter long. The part number for the cable is 012-1408-00. Figure 7-8 shows an example of the standard accessory cable and a receiving connector.

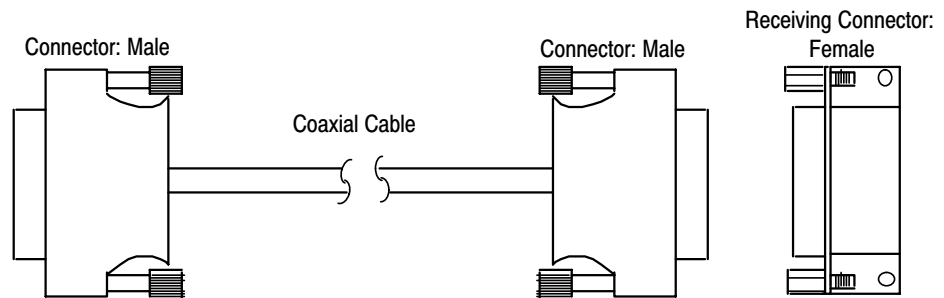

Figure 7-8: Cable Examples

Digital Data Latch Example. Figure 7-9 shows an example of an external circuit for latching the digital data.

NOTE. Tektronix cannot be responsible for the infringement of any third-party industrial proprietary rights, copyrights, or other rights arising from the use of these circuits.

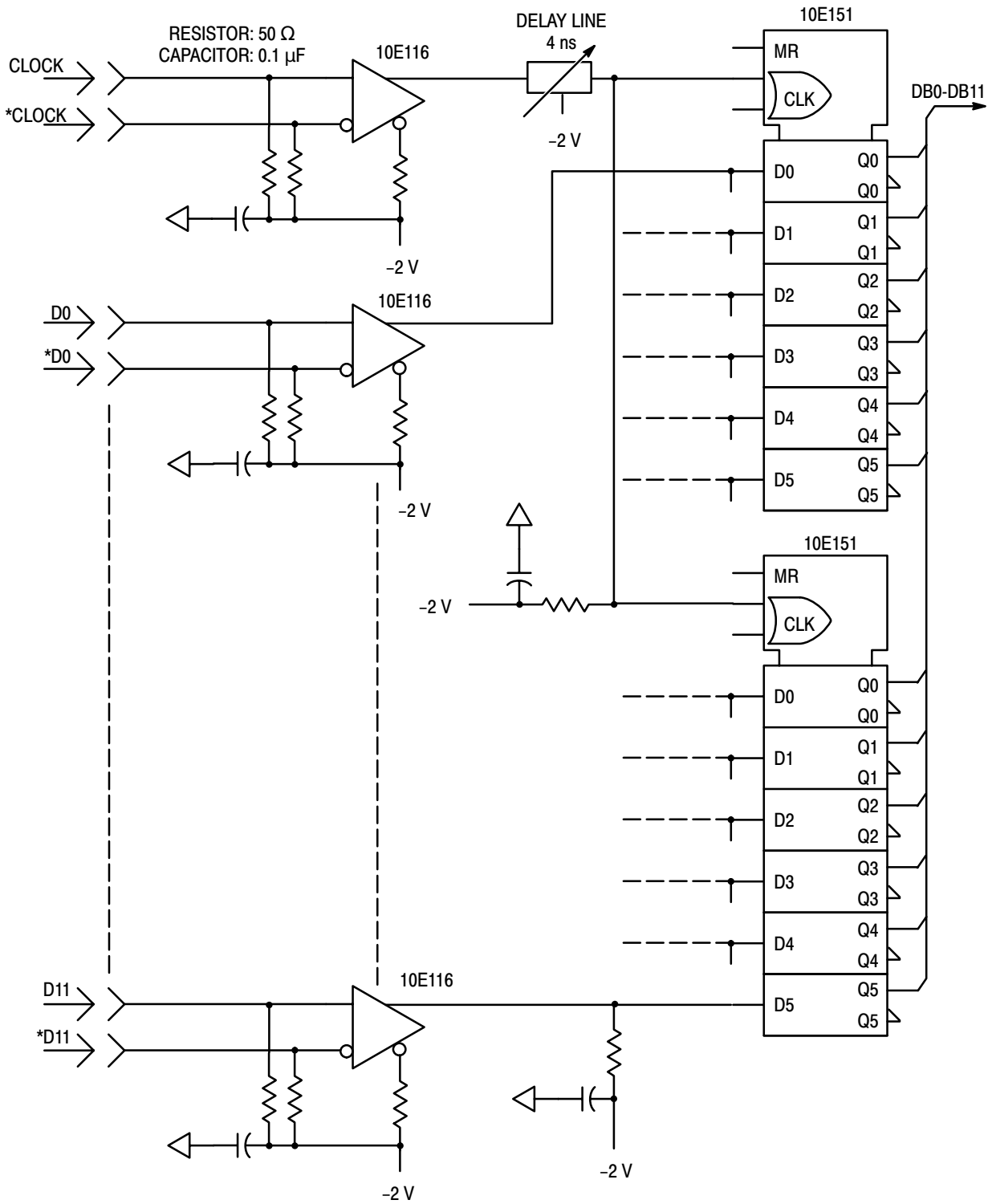

Figure 7-9: Digital Data Latch Example

Option 04 Description

The AWG2021 arbitrary waveform generator with Option 04 installed can provide the following signals at the rear panel output connector. This option cannot be installed with Option 03 or Option 09.

Data Output The data (D0–D11) fed to the internal D/A converter is buffered and connected to the output connector. At the same time that the analog waveform is output, the digital output can be obtained. The output is TTL level.

Clock Output The same clock that goes to the internal D/A converter is buffered and routed to the connector. The clock output is also TTL level.

Figure 7–10 is a block diagram of the digital data output Option 04.

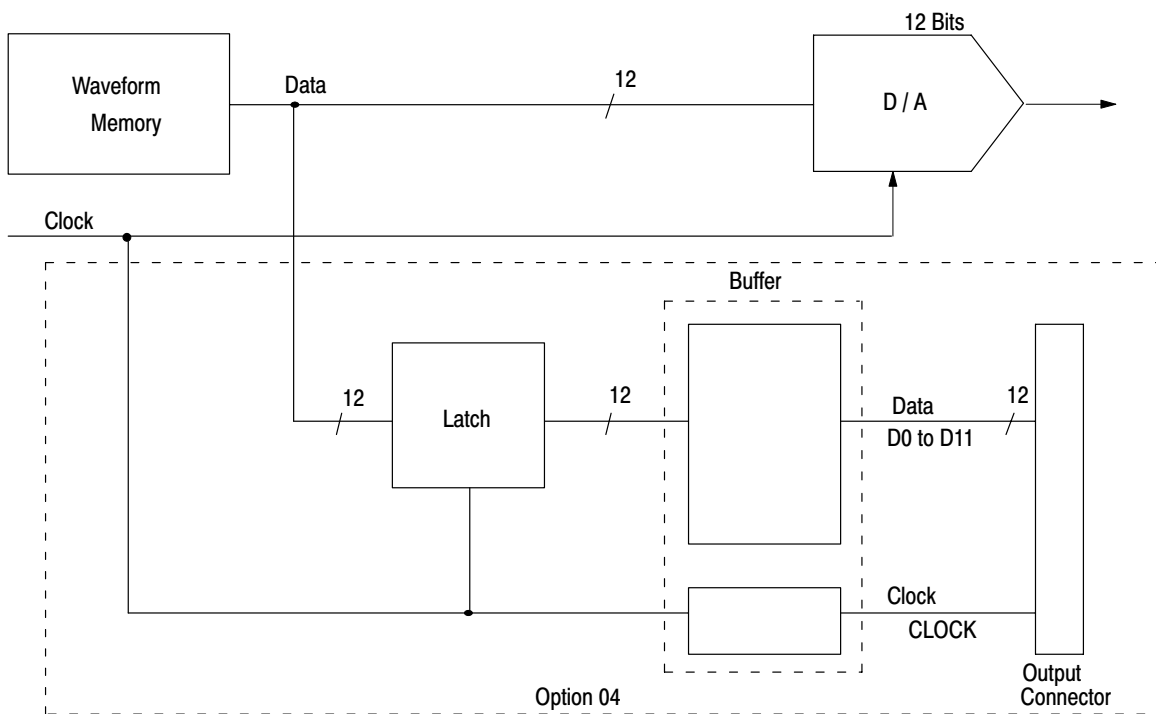

Figure 7–10: Block Diagram

Output Connector Configuration

Figure 7–11 shows the shape and pin number location of the output connector, and Table 7–3 shows the output signal for each pin.

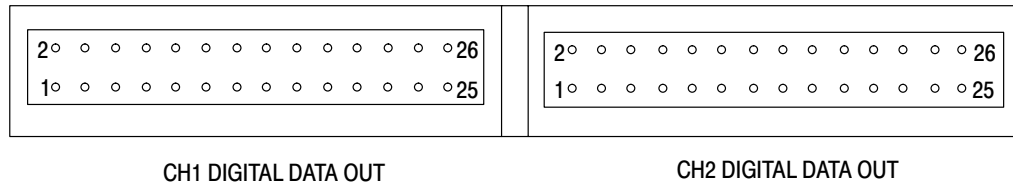

Figure 7–11: Option 04 Output Connector

Table 7–3: Option 04 Connector Pin Assignments

Pin Number	Signal	Pin Number	Signal
1	D0 (LSB)	15	D7
3	D1	17	D8
5	D2	19	D9
7	D3	21	D10
9	D4	23	D11 (MSB)
11	D5	25	Clock
13	D6		

Pins other than those listed above are connected to ground. The pin assignments are identical for both CH1 and CH2.

Operation

Operation when Option 04 is installed is basically the same as the standard AWG2021 operation. When a waveform is not being output, the waveform's initial data may be output to the connector. At this time, the clock is not generated.

When starting the waveform output, the clock is generated and the data is updated.

NOTE. When loading a new waveform into waveform memory, resetting the waveform memory, or during the hold off, excess output can be generated in the data clock (see Figure 7–12).

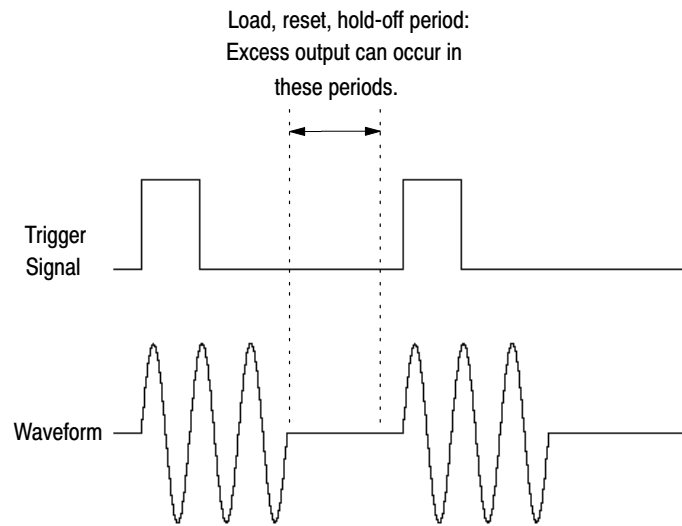

Figure 7-12: Generation of Excess Output

Output Circuit and Output Waveform

Figure 7-13 shows a diagram of the output circuit. After first passing through an output resistance of $50\ \Omega$, the buffer output is routed to the output connectors. The AWG2021 can be used without terminating the receiving (user) side with a resistance of $50\ \Omega$, but when waveform distortion is great the $50\ \Omega$ termination is required.

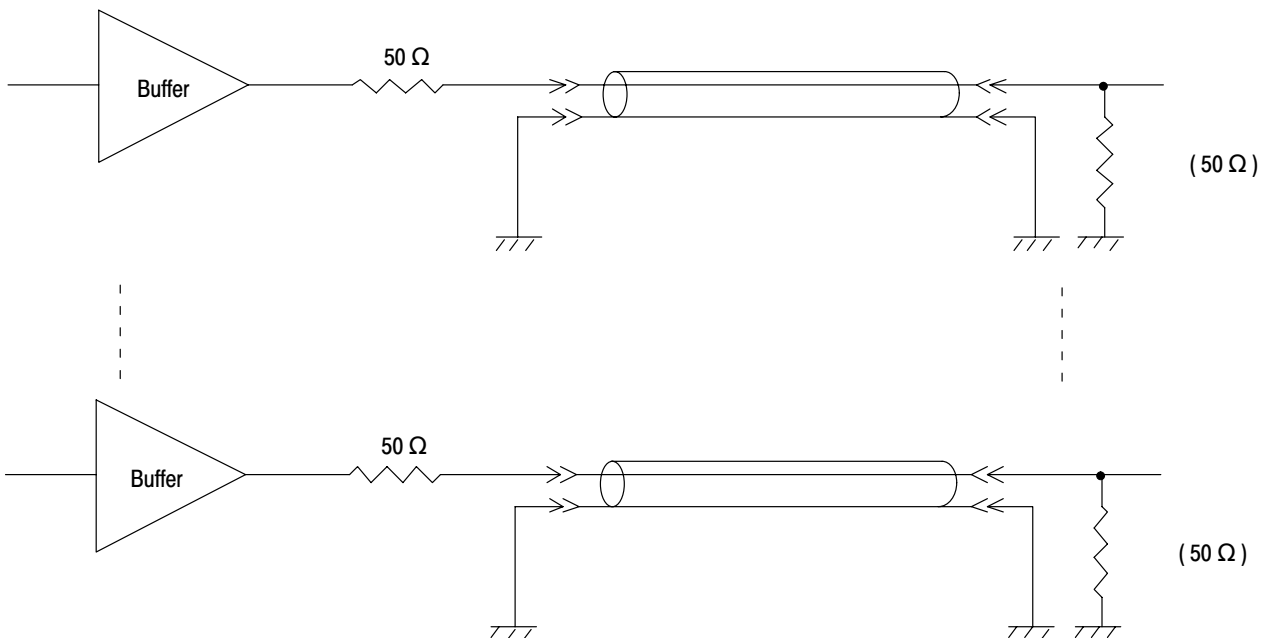

Figure 7-13: Output Circuit

The skew of the data output is limited to ± 2 ns on the same channel, and ± 4 ns between CH1 and CH2. Figure 7-14 shows the specifications for the waveform at the output connector when a cable is not being used.

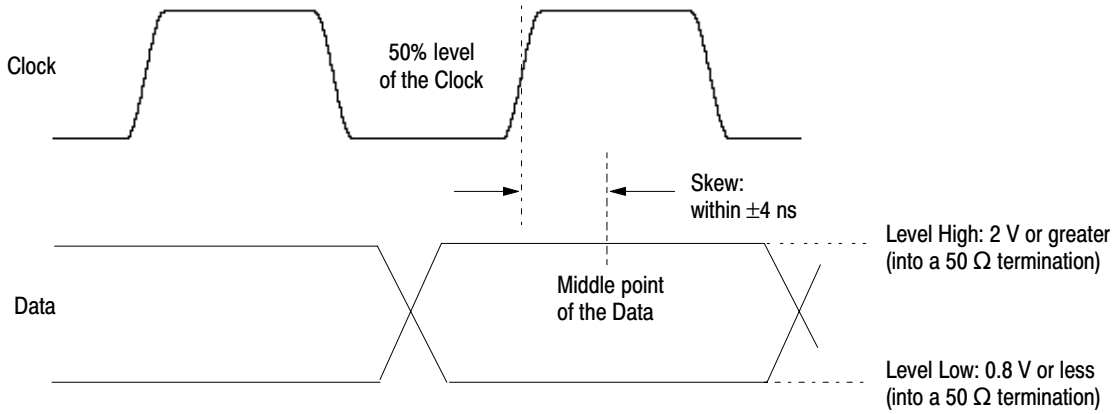

Figure 7-14: Output Waveform

Output waveforms will have transmission distortion if a cable is used. It is necessary to latch the data with a clock before using the waveform at the cable receiving side (user side), and to reproduce the waveform. Delay the clock with the delay line in order to reproduce the data reliably (see Figure 7-15).

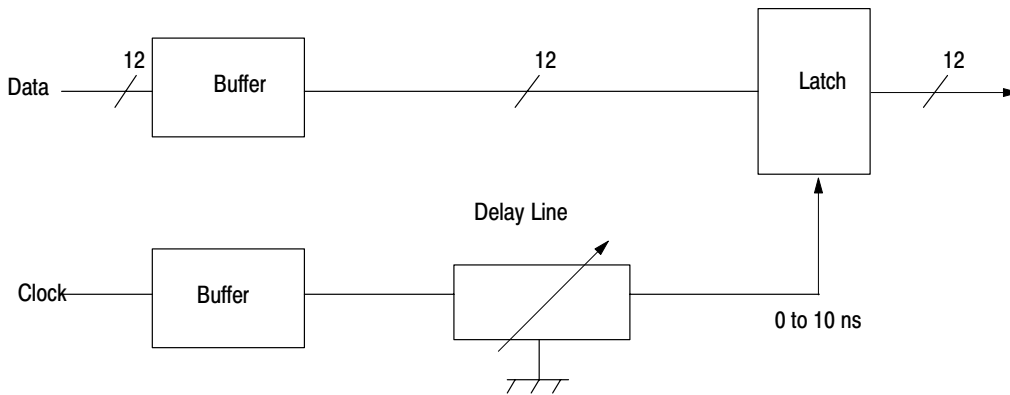

Figure 7-15: Data Latching

Application Example **Cables.** The cable connecting the AWG2021 and the user circuit is extremely critical for reliable operation at the maximum clock frequency.

NOTE. Use a coaxial cable with a characteristic impedance of $50\ \Omega$ for all DATA and CLOCK lines.

Keep cables as short as possible. Performance depends on the characteristic of the coaxial cable used, but lengths under one meter are desirable.

Cable Examples. The AWG2021 with Option 04 comes with a digital data out cable as a standard accessory. The cable is one meter long and is illustrated in Figure 7–16. The part number for the cable is 174-3192-00.

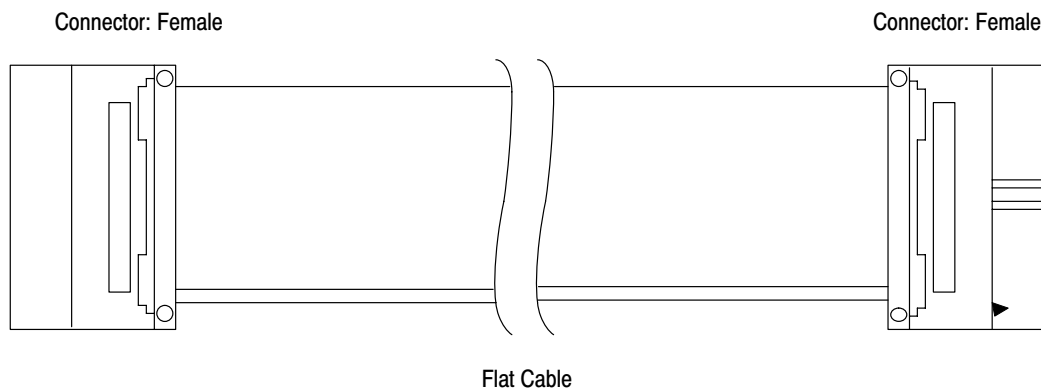

Figure 7–16: Digital Data Out Cable

Waveform Regeneration

In some cases, even a cable that has been carefully made will create transmission distortion. Figure 7–17 shows an example of a circuit used to regenerate the waveform.

NOTE. Tektronix cannot be responsible for the infringement of any third-party industrial proprietary rights, copyrights, or other rights arising from the use of these circuits.

NOTE. The ECB is a multi-layer board. One layer is used as ground and the other as the power supply. The data lines are the same length so that their delay times are equal.

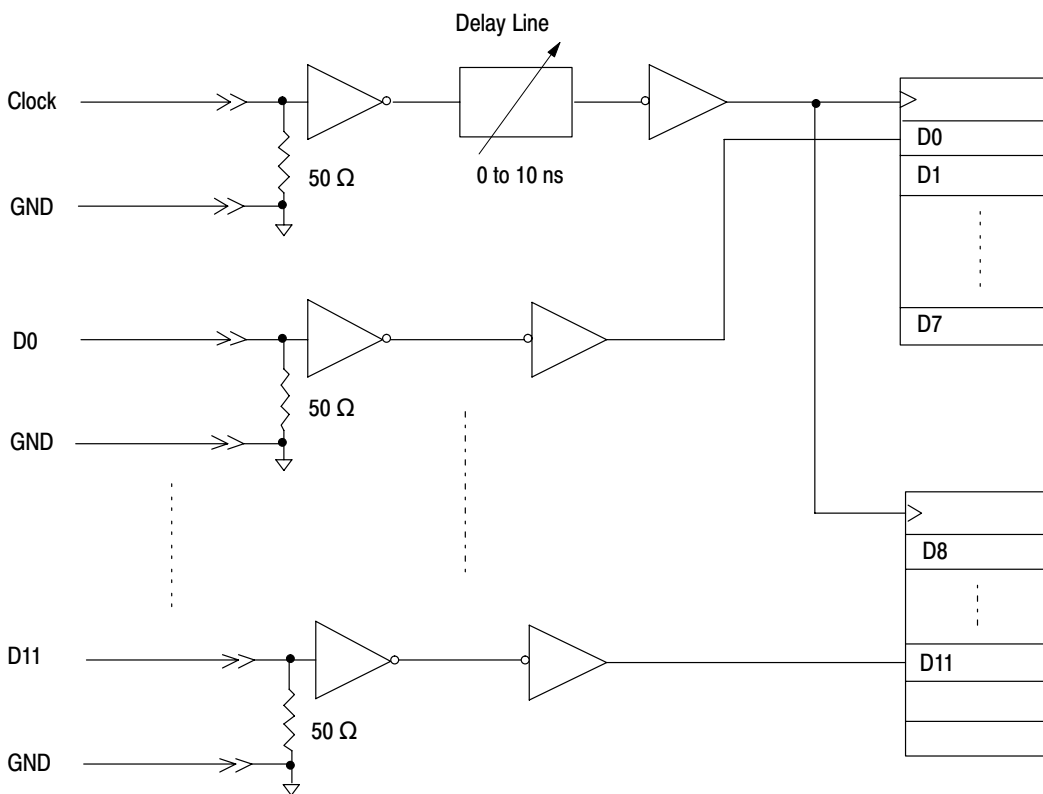

Figure 7–17: Example of Waveform Reproduction Circuit

Option 09 Description

This option provides increased internal calculation speed and two additional editors: an FFT editor and a convolution editor.

Option 1R Description

For Option 1R, the waveform generator is configured for installation in a 19-inch wide instrument rack. In this configuration, the floppy disk drive is mounted on the front panel. To change an AWG2021 into a rackmount version, you can order an upgrade kit.

Option 1S Description

WaveWriter is an application program used to create waveforms for advanced signal generating and processing instruments. Many Tektronix instruments, such as arbitrary waveform generators and oscilloscopes with the “save-on-delta” feature, are enhanced by this program. WaveWriter helps users configure waveforms with a minimum of effort.

With the WaveWriter package, you can create new waveforms or edit waveforms acquired from various instrument sources. WaveWriter gives you interactive control of the waveform generating process. WaveWriter operates within the Microsoft Windows™ environment.

Option 95 Description

A test result report will be provided with the AWG2021 when this option is specified.

Accessories

Standard Accessories

The following standard accessories are provided with each instrument:

Table 7-4: Standard Accessories List

Qty	Description	Part Number
1	User manual	070-9097-XX
1	Programmer manual	070-8657-XX
1	GPIB Programming Examples Disk, 3.5-inch media	063-1708-XX
1	Sample Waveform Library Disk, 3.5-inch media	063-2169-XX
1	Performance Check/Adjustment Disk	063-2171-XX
1	Power cable	161-0230-01
1	ECL Digital Data Out cable (for Option 03)	012-1408-XX
1	TTL Digital Data Out cable (for Option 04)	174-3192-XX
1	Certificate of Calibration	

Optional Accessories

The following optional accessories are recommended for use with the instrument:

Table 7-5: Optional Accessories List

Qty	Description	Part Number
1	Service manual	070-9098-XX
1	Front cover	200-3232-XX
1	Accessory pouch	016-1159-XX
1	C9 camera adapter	016-1154-XX
1	GPIB cable	012-0991-XX
1	Termination board (for Option 03)	671-2957-XX
1	50 Ω BNC cable	012-1342-XX
1	50 Ω BNC cable, double-shielded	012-1256-XX
1	SMA(Ma)-BNC(Fe) cable	015-0554-XX
1	50 Ω BNC terminator	011-0049-XX
1	Maintenance kit (see Table 7-6)	067-1396-XX
1	Fuse (6 A, 250 V, fast-blow)	159-0239-XX
1	Fuse cap	200-2264-XX

Table 7-5: Optional Accessories List (Cont.)

Qty	Description	Part Number
1	Fuse 5 A (T) (IEC127)	159-0210-XX
1	Fuse cap	200-2265-XX

Table 7-6: Maintenance Kit Contents

Qty	Description	Part Number
1	Extender-A board (for slot 1, 2, 3, 4)	671-2331-XX
1	Extender-B board (for slot 5)	671-2487-XX
1	Cable kit	198-5802-XX
1	Ejector	003-1315-XX
1	Header	131-5537-XX
1	Connector (PELTOLA-to-BNC)	131-1315-XX

Replaceable Electrical Parts

Electrical Parts List

The modules that make up this instrument are often a combination of mechanical and electrical subparts. Therefore, all replaceable modules are listed in section 10, *Mechanical Parts List*. Refer to that section for part numbers when using this manual.

Diagrams

Diagrams

This section contains following diagrams:

- Block Diagram of AWG2021 with Options 02 and 09
- Block Diagram of AWG2021 with Options 02 and 03
- Block Diagram of AWG2021 with Options 02 and 04
- Interconnect Diagram of AWG2021 with Options 02, 04, and 09
- Interconnect Diagram of AWG2021 Option 03

Block diagrams show the modules and functional blocks in the AWG2021.
Interconnect diagrams show how the modules in the AWG2021 connect together.

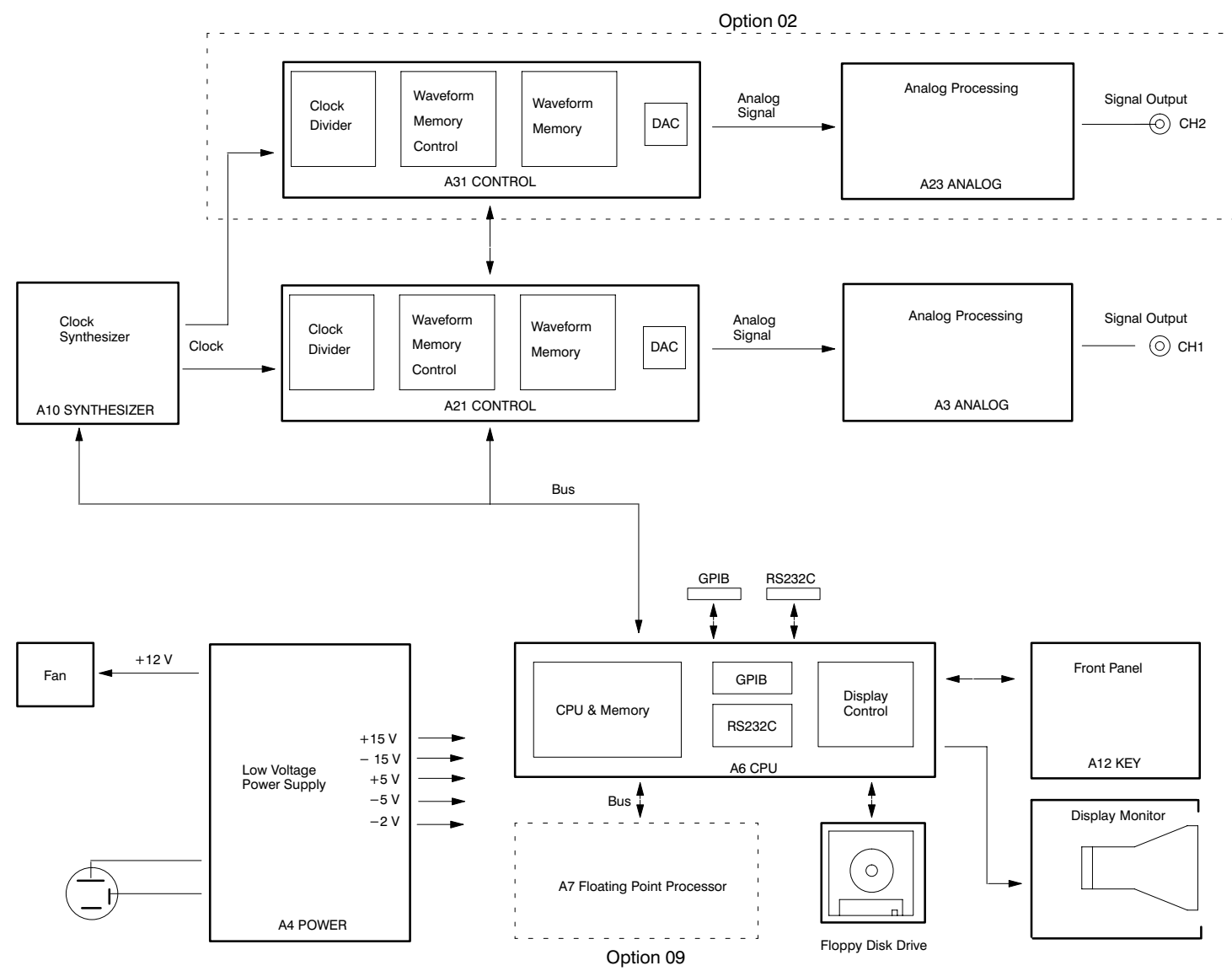

Figure 9-1: Block Diagram of AWG2021 with Options 02 and 09

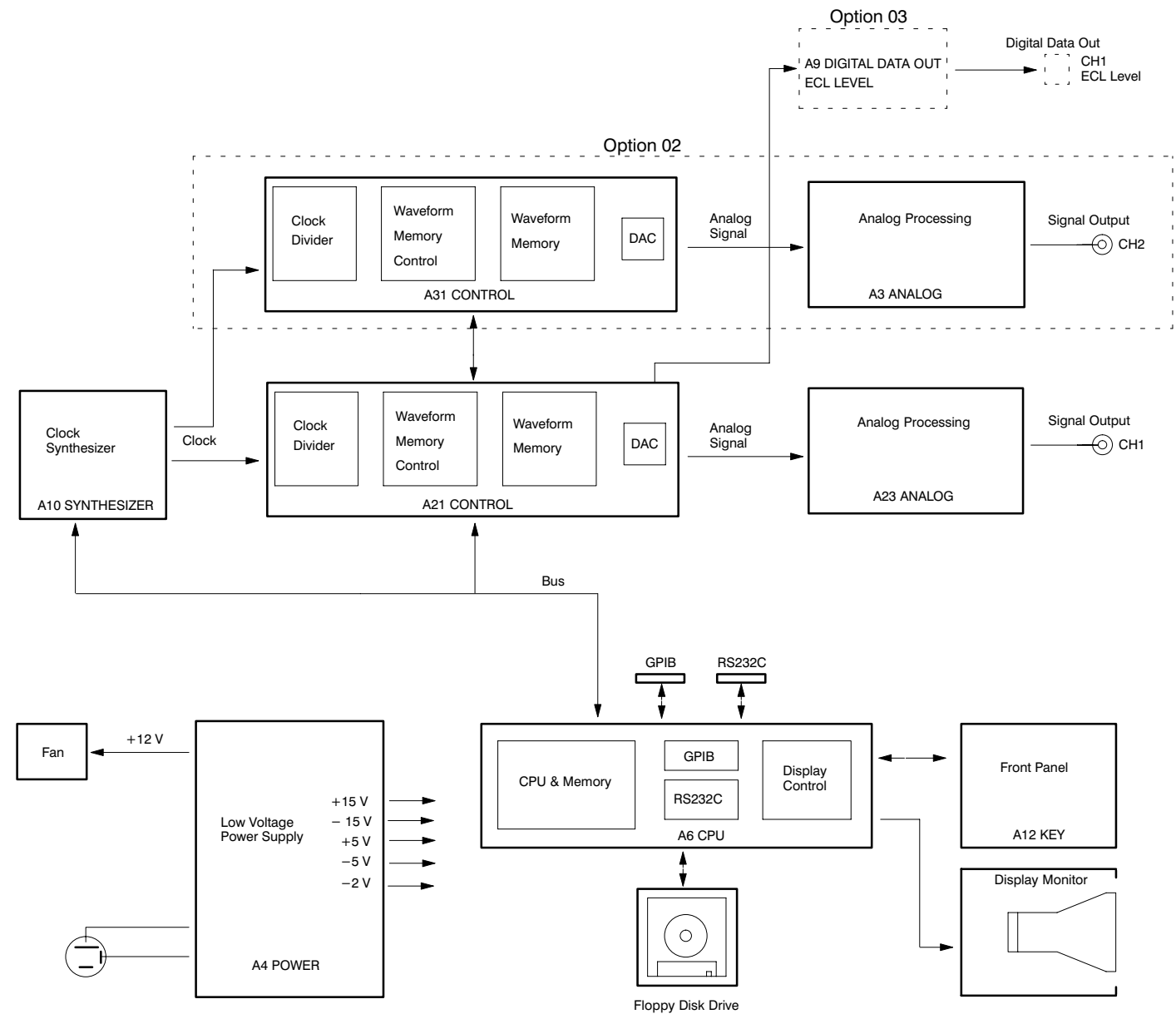

Figure 9-2: Block Diagram of AWG2021 with Options 02 and 03

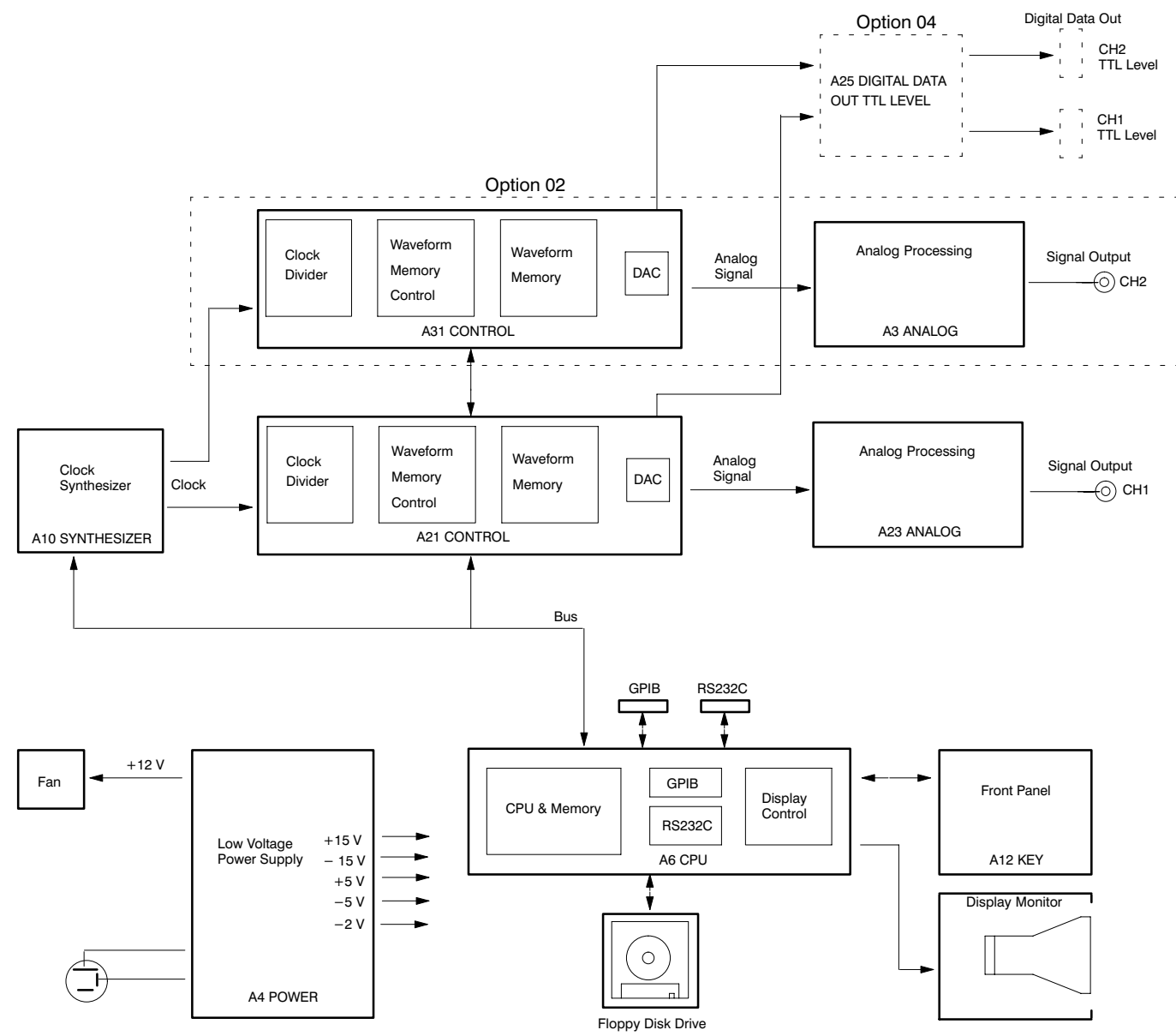

Figure 9-3: Block Diagram of AWG2021 with Options 02 and 04

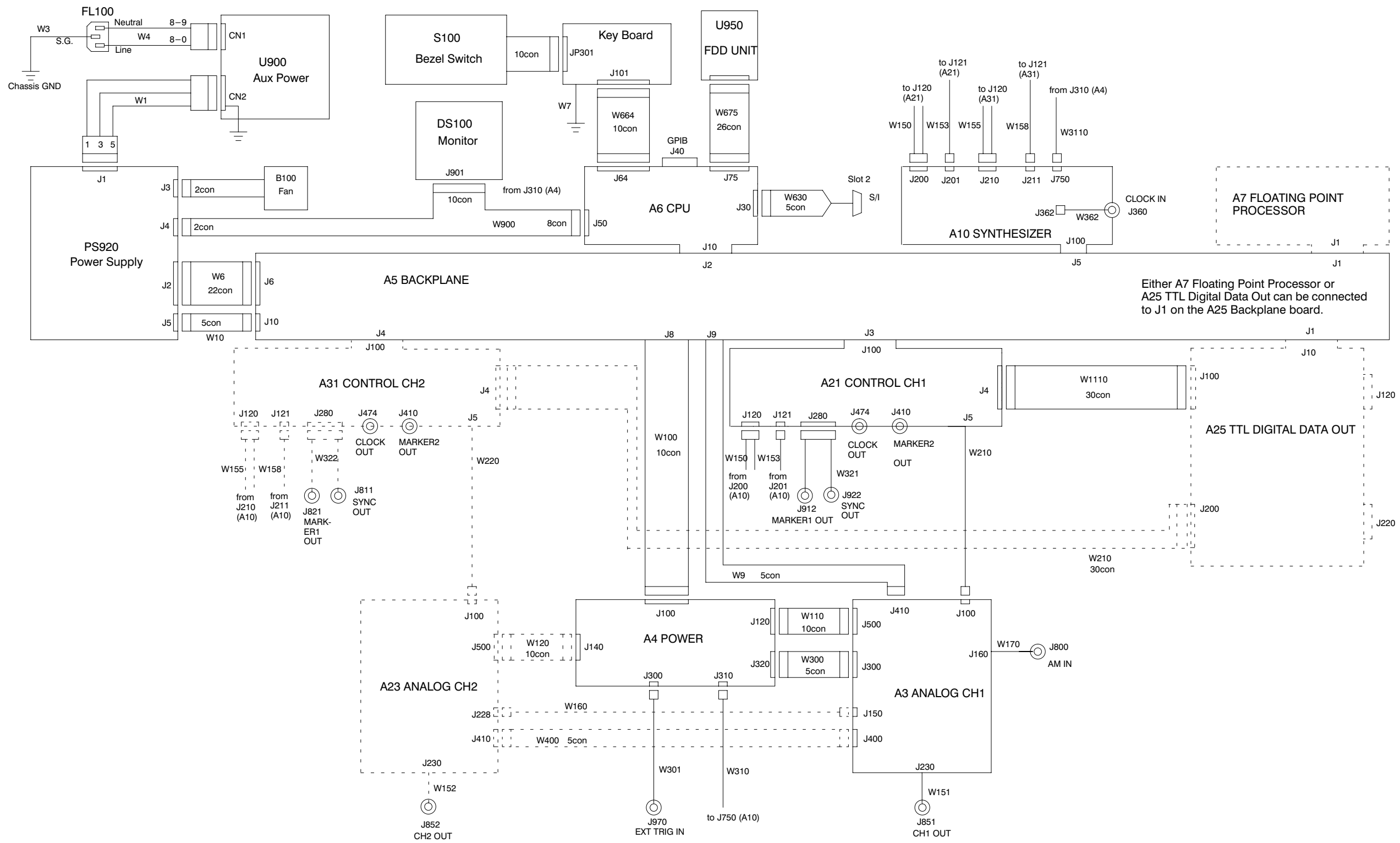

Figure 9-4: Interconnect Diagram of AWG2021 with Options 02, 04, and 09

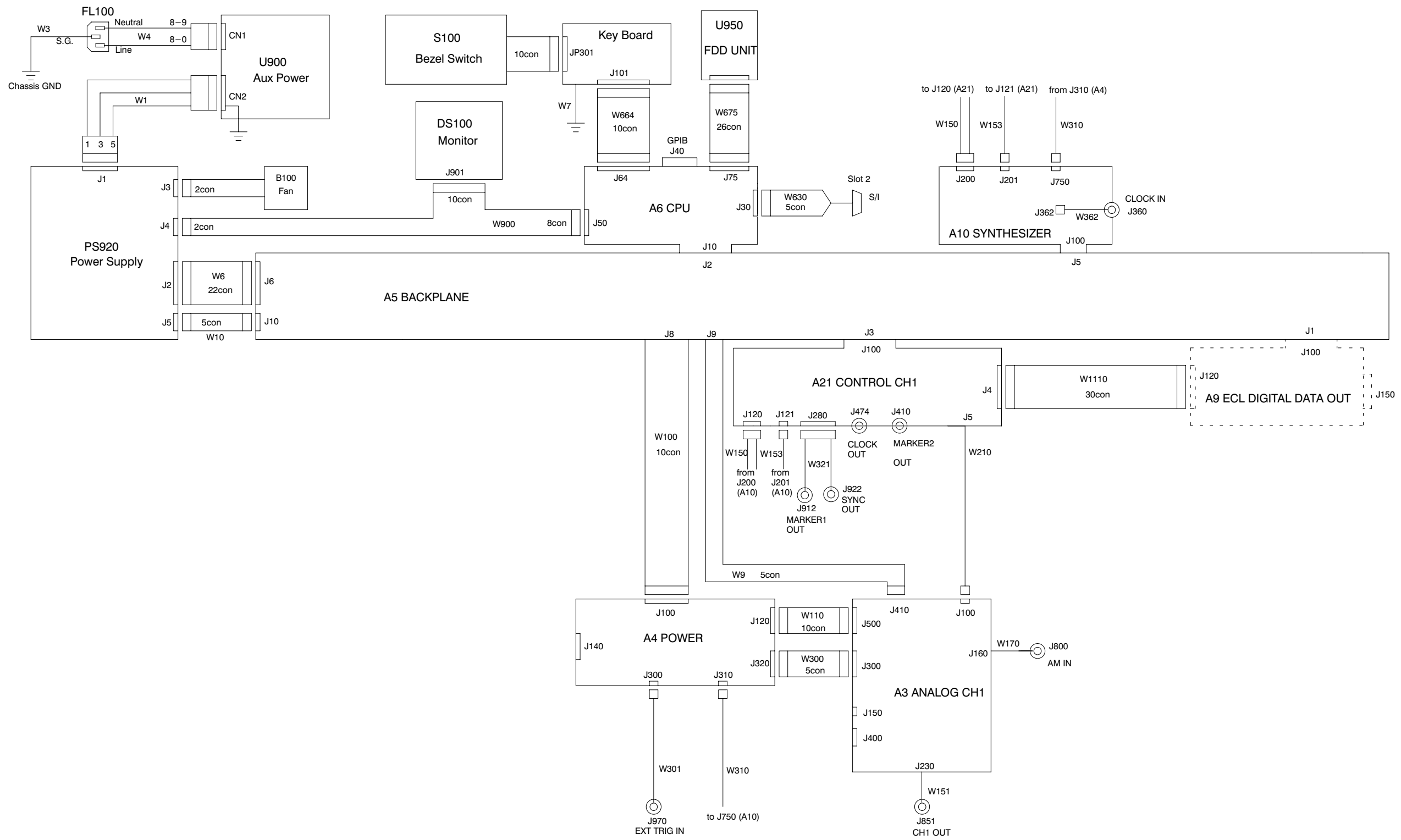

Figure 9-5: Interconnect Diagram of AWG2021 Option 03

Replaceable Mechanical Parts

Replaceable Mechanical Parts

This section contains a list of the replaceable modules for the AWG2021. Use this list to identify and order replacement parts.

Parts Ordering Information

Replacement parts are available through your local Tektronix field office or representative.

Changes to Tektronix products are sometimes made to accommodate improved components as they become available and to give you the benefit of the latest improvements. Therefore, when ordering parts, it is important to include the following information in your order.

- Part number (see Part Number Revision Level below)
- Instrument type or model number
- Instrument serial number
- Instrument modification number, if applicable

If you order a part that has been replaced with a different or improved part, your local Tektronix field office or representative will contact you concerning any change in part number.

Change information, if any, is located at the rear of this manual.

Part Number Revision Level

Tektronix part numbers contain two digits that show the revision level of the part. For most parts in this manual, you will find the letters XX in place of the revision level number.

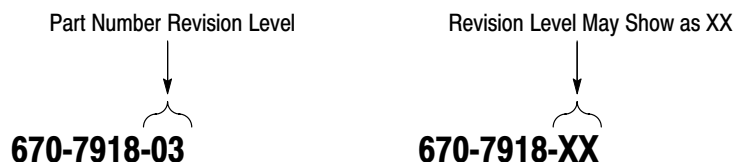

When you order parts, Tektronix will provide you with the most current part for your product type, serial number, and modification (if applicable). At the time of your order, Tektronix will determine the part number revision level needed for your product, based on the information you provide.

Module Servicing Modules can be serviced by selecting one of the following three options. Contact your local Tektronix service center or representative for repair assistance.

Module Exchange. In some cases you may exchange your module for a remanufactured module. These modules cost significantly less than new modules and meet the same factory specifications. For more information about the module exchange program, call 1-800-TEK-WIDE, extension 6630.

Module Repair and Return. You may ship your module to us for repair, after which we will return it to you.

New Modules. You may purchase replacement modules in the same way as other replacement parts.

Using the Replaceable Parts List

This section contains a list of the mechanical and/or electrical components that are replaceable for the AWG2021. Use this list to identify and order replacement parts. The following table describes each column in the parts list.

Parts List Column Descriptions

Column	Column Name	Description
1	Figure & Index Number	Items in this section are referenced by figure and index numbers to the exploded view illustrations that follow.
2	Tektronix Part Number	Use this part number when ordering replacement parts from Tektronix.
3 and 4	Serial Number	Column three indicates the serial number at which the part was first effective. Column four indicates the serial number at which the part was discontinued. No entries indicates the part is good for all serial numbers.
5	Qty	This indicates the quantity of parts used.
6	Name & Description	An item name is separated from the description by a colon (:). Because of space limitations, an item name may sometimes appear as incomplete. Use the U.S. Federal Catalog handbook H6-1 for further item name identification.
7	Mfr. Code	This indicates the code of the actual manufacturer of the part.
8	Mfr. Part Number	This indicates the actual manufacturer's or vendor's part number.

Abbreviations Abbreviations conform to American National Standard ANSI Y1.1-1972.

Mfr. Code to Manufacturer Cross Index The table titled Manufacturers Cross Index shows codes, names, and addresses of manufacturers or vendors of components listed in the parts list.

Manufacturers Cross Index

Mfr. Code	Manufacturer	Address	City, State, Zip Code
80009	TEKTRONIX, INC.	P.O. BOX 500	BEAVERTON, OR, 97077-0001
K1072	GREENPAR CONNECTORS LTD	PO BOX 15	HARLOW ESSEX, CM20 2ER UK
S3109	FELLER	72 VERONICA AVE UNIT 4	SUMMERSET NJ 08873
TK0BD	TAISHO ELECTRIC IND CO LTD	5-28-16 OKUSAWA SETAGAYA-KU	TOKYO JAPAN
TK0191	SONY/TEKTRONIX	PO BOX 5209 TOKYO INTERNATIONAL	TOKYO JAPAN 100-31
TK0392	NORTHWEST FASTENER SALES INC	7923 SW CIRRUS DRIVE	BEAVERTON OR 97005-6448
TK0435	LEWIS SCREW CO	4300 S RACINE AVE	CHICAGO IL 60609-3320
TK1163	POLYCAST INC	9898 SW TIGARD ST	TIGARD OR 97223
TK1572	RAN-ROB INC	631 85TH AVE	OAKLAND CA 94621-1254
TK1908	PLASTIC MOLDED PRODUCTS	4336 SO ADAMS	TACOMA WA 98409
TK1918	SHIN-ETSU POLYMER AMERICA INC	1181 NORTH 4TH ST	SAN JOSE CA 95112
TK2058	TDK CORPORATION OF AMERICA	1600 FEEHANVILLE DRIVE	MOUNT PROSPECT, IL 60056
TK2432	UNION ELECTRIC	15/F #1, FU-SHING N. ROAD	TAIPEI, TAIWAN ROC
TK2548	XEROX BUSINESS SERVICES DIV OF XEROX CORPORATION	14181 SW MILLIKAN WAY	BEAVERTON OR 97077
OJR05	TRIQUEST CORP	3000 LEWIS AND CLARK HWY	VANCOUVER WA 98661-2999
OKB01	STAUFFER SUPPLY	810 SE SHERMAN	PORTLAND OR 97214
00779	AMP INC	2800 FULLING MILL PO BOX 3608	HARRISBURG PA 17105
07416	NELSON NAME PLATE CO	3191 CASITAS	LOS ANGELES CA 90039-2410
2W733	BELDEN CORPORATION	2200 US HIGHWAY 27 SOUTH PO BOX 1980	RICHMOND IN 47375-0010
24931	SPECIALTY CONNECTOR CO INC	2100 EARLYWOOD DR PO BOX 547	FRANKLIN IN 46131
6D224	HARBOR TRI-TEC A BERG ELECTRONICS COMPANY	14500 SOUTH BROADWAY	GARDENA, CA 90248
61058	MATSUSHITA ELECTRIC CORP OF AMERICA PANASONIC INDUSTRIAL CO DIV	TWO PANASONIC WAY	SECAUCUS NJ 07094
61857	SAN-0 INDUSTRIAL CORP	91-3 COLIN DRIVE	HOLBROOK NY 11741
61935	SCHURTER INC	1016 CLEGG COURT	PETALUMA CA 94952-1152
64537	KDI/TRIANGLE ELECTRONICS	60 S JEFFERSON ROAD	WHIPPANY, NJ 07981
73743	FISCHER SPECIAL MFG CO	111 INDUSTRIAL RD	COLD SPRING KY 41076-9749
78189	ILLINOIS TOOL WORKS INC SHAKEPROOF DIV	ST CHARLES ROAD	ELGIN IL 60120
80009	TEKTRONIX INC	14150 SW KARL BRAUN DR PO BOX 500	BEAVERTON OR 97077-0001
86928	SEASTROM MFG CO INC	701 SONORA AVE	GLENDALE CA 91201-2431

Replaceable Parts List

Fig. & Index Number	Tektronix Part Number	Serial No. Effective	Serial No. Discont'd	Qty	Name & Description	Mfr. Code	Mfr. Part Number
10-1-1	343-1213-XX			1	CLAMP,PWR CORD:POLYIMIDE	TK1163	ORDER BY DESC
-2	161-0230-01			1	CABLE ASSY,PWR,;3,18 AWG,92 L (STANDARD ACCESSORY)	TK2432	ORDER BY DESC
-3	334-8705-XX			1	MARKER,IDENT:MKD WARRNING/FUSE DATA	80009	334-8705-XX
-4	334-3388-XX			1	MARKER,IDENT:MKD,SONY/TEKTRONIX	80009	334-3388-XX
-5	334-8410-XX	J300101	J310261	1	MARKER,IDENT:BLANK,POLYESTER	80009	334-8410-XX
-6	334-8859-XX			1	MARKER,IDENT:MKD I/O SIGNALS,CH1 & CH2	80009	334-8859-XX
-7	211-0691-XX			4	SCR,ASSEM WSHR:6-32 X 0.625,PNH,STL,T-15	0KB01	ORDER BY DESC
-8	200-3991-XX			1	COVER,REAR:HARD,POLYCARBONATE,LEXAN	TK1163	ORDER BY DESC
-9	390-1145-XX			1	CABINET,SCOPE:AL,TEK BLUE	80009	390-1145-XX
-10	211-0378-XX			4	SCR,ASSEM WSHR:4-40 X 0.375.PNH,STL,T9	0KB01	ORDER BY DESC
-11	200-3983-XX			1	BEZEL:FDD,AL	80009	200-3983-XX
-12	348-1276-XX			1	GASKET,SHIELD:CONDUCTIVE FORM STRIP	80009	348-1276-XX
-13	260-2539-XX			1	SWITCH,SET;ELASTOMERIC BEZEL	TK1918	260-2539-XX
-14	366-2164-XX			14	PUSH BUTTON:SMOKE TAN	80009	366-2164-XX
-15	354-0709-XX			1	RING,TRIM:LEXAN 940	80009	354-0709-XX
-16	334-8862-XX			1	MARKER,IDENT:MKD AWG2021,POLYCARB	80009	334886200
-17	378-0404-XX			1	FILTER,LT,CRT:BULE SMOKE,112 X 145 X1MM	80009	378-0404-XX
-18	348-1289-XX			1	SHLD GSKT,ELEK:MESH TYPE,3.2MM X 4.7MM	80009	348-1289-XX
-19	211-0722-XX			1	SCREW,MACHINE:6-32 X 0.250,PNH,STL,T-15	0KB01	ORDER BY DESC

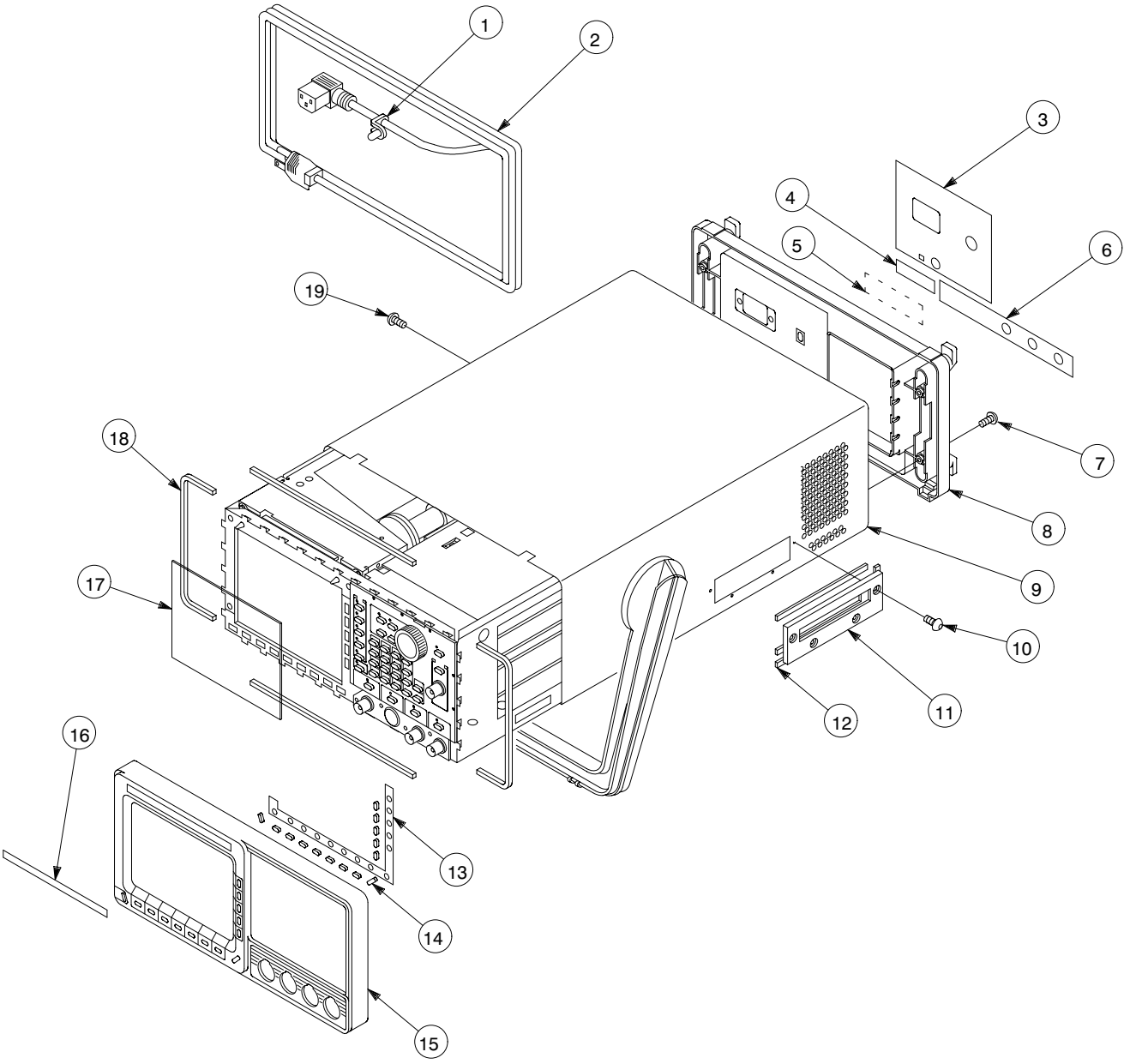

Figure 10-1: Cabinet

Replaceable Parts List

Fig. & Index Number	Tektronix Part Number	Serial No. Effective	Serial No. Discont'd	Qty	Name & Description	Mfr. Code	Mfr. Part Number
10-2-1	213-0882-XX			6	SCREW,TPG,TR:6-32 X 0.437,PNH,STL,T-15	0KB01	ORDER BY DESC
-2	119-4322-XX			1	FAN,TUBAXIAL:12VDC,2.4M/M,5.8MM HZO,6W (B100)	80009	119-4322-XX
-3	252-0571-XX			1	PLASTIC SHEET:EXTR CHAN,5MM X 3.3MM	80009	252-0571-XX
-4	342-0993-XX			1	INSULATOR,FILM:PWR SPLY,POLYCARB	TK0191	342-0993-XX
-5	211-0722-XX			2	SCREW,MACHINE:6-32 X 0.250,PNH,STL,T-15	0KB01	ORDER BY DESC
-6	620-0058-XX	J300101	J320100	1	POWER SUPPLY:185W;SWITCHING,15V/4A,12V (PS920)	80009	620-0058-XX
	620-0065-XX	J320101		1	POWER SUPPLY:185W;SWITCHING,15V/4A,12V (PS920)	80009	620-0065-XX
-7	213-0882-XX			4	SCREW,TPG,TR:6-32 X 0.437,PNH,STL,T-15	0KB01	ORDER BY DESC
-8	366-1480-XX			1	PUSH BUTTON:GRAY,0.328 X 0.253 X 0.43	0JR05	ORDER BY DESC
-9	-----			1	CAP,FUSEHOLDER (P/O TABLE 2-2)		
-10	-----			1	FUSE,CARTRIDGE (P/O TABLE 2-2)		
-11	119-4315-XX	J300101	J310244	1	CIRCUIT BD ASSY:AUX,POWER SUPPLY (U900)	80009	119-4315-XX
	671-3351-XX	J310245		1	CIRCUIT BD ASSY:AUX,POWER SUPPLY (A900)	80009	670-3351-XX
-12	213-0882-XX			2	SCREW,TPG,TR:6-32 X 0.437,PNH,STL,T-15	0KB01	ORDER BY DESC
-13	119-2683-XX			1	FILTER,RFI:50/60HZ,250VAC,6A (FL100)	TK2058	ZUB2206H-F
-14	426-2426-XX			1	FRAME,FAN MTG:POLYCARBONATE	TK1163	426-2426-XX
-15	210-0457-XX			1	NUT,PL,ASSEM WA:6-32 X 0.312,STL	TK0435	ORDER BY DESC
-16	334-3379-XX			1	MARKER,IDENT:MARKED GROUND SYMBOL	07416	ORDER BY DESC
-17	441-2074-XX			1	CHASSIS,ASSY:ALUM	80009	441-2074-XX
-18	210-0586-XX			2	NUT,PL,ASSEM WA:4-40 X 0.25,STL	TK0435	ORDER BY DESC
-19	344-0472-XX			1	CLIP,CABLE:NYLON,GRAY	80009	344-0472-XX
-20	131-0955-XX			2	CONN,RF JACK:BNC,;50 OHM,FEMALE (L912,J922)	K1072	G35152BN
-21	210-0255-XX			2	TERMINAL,LUG:0.391 ID,LOCKING,BRS	TK1572	ORDER BY DESC
-22	407-4087-XX	J300101	J320436	1	BRKT,CMPNT,BNC:ALUMINUM,5.250 X 1.050	80009	407-4087-XX
	407-4394-XX	J310437		1	BRKT,CMPNT,BNC:ALUMINUM,5.250 X 1.050	80009	407-4394-XX
-23	211-0325-XX			4	SCR,ASSEM WSHR:4-40 X 0.250,PNH,STL,T-9	0KB01	ORDER BY DESC
-24	134-0218-XX			1	BUTTON,PLUG:0.625 DIA,PLASTIC,TAN	80009	134-0218-XX
-25	210-0005-XX			1	WASHER,LOCK:#6 EXT,0.02 THK,STL	78189	1106-00
-26	211-0722-XX			1	SCREW,MACHINE:6-32 X 0.250,PNH,STL,T-15	0KB01	ORDER BY DESC
-27	131-1315-XX			1	CONN,RF JACK:BNC/PNL,;50 OHM,FEMALE (J851)	24931	28JR306-1
-28	259-0086-XX			1	FLEX CIRCUIT:BEZEL BUTTON (S100)	07416	ORDER BY DESC
-29	348-1313-XX			1	GASKET,SHIELD:CONDUCTIVE URETHANE FORM	80009	348-1313-XX

Replaceable Parts List (Cont.)

Fig. & Index Number	Tektronix Part Number	Serial No. Effective	Serial No. Discont'd	Qty	Name & Description	Mfr. Code	Mfr. Part Number
-30	426-2436-XX			1	FRAME,CRT FLTR:POLYCARBONATE,BLACK	80009	426-2436-XX
-31	348-1302-XX			1	GASKET,SHIELD:CONDUCTIVE URETHANE FORM	80009	348-1302-XX
-32	640-0081-XX			1	DISPLAY,MONITOR:7 INCH,640 X 480 PIXEL (DS100)	80009	640-0081-XX

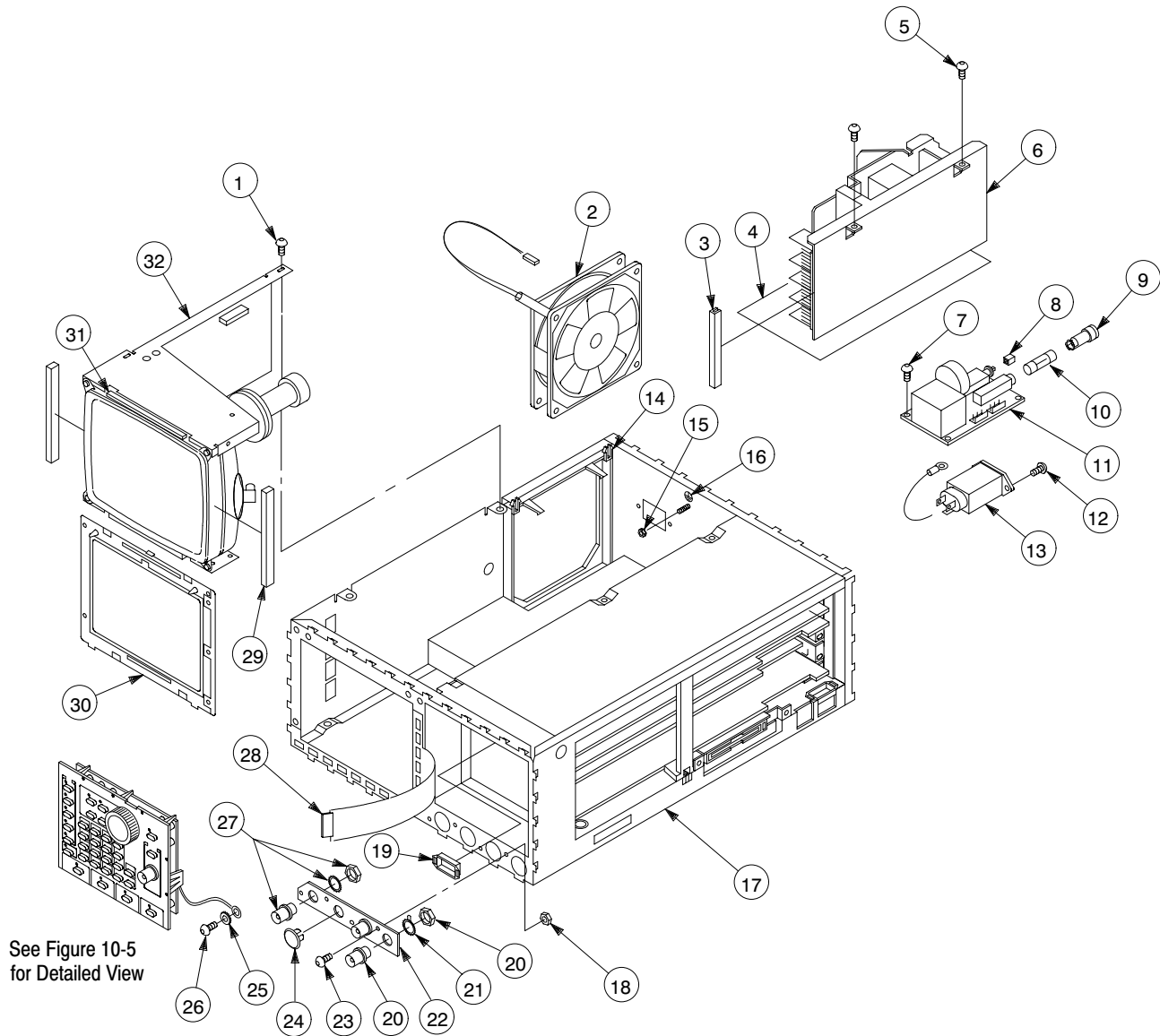

Figure 10-2: Main Chassis and CRT

Replaceable Parts List

Fig. & Index Number	Tektronix Part Number	Serial No. Effective	Serial No. Discont'd	Qty	Name & Description	Mfr. Code	Mfr. Part Number
10-3-1	131-1315-XX			1	CONN,RF JACK:BNC/PNL,,50 OHM,FEMALE (J800)	24931	28JR306-1
-2	134-0218-XX			2	BUTTON,PLUG:0.625 DIA,PLASTIC,TAN	80009	134-0218-XX
-3	348-1314-XX			1	GSKT,SHIELD:FINGER RYPE,BE-CU,609.6MM L	80009	348-1314-XX
-4	211-0722-XX	J300101	J310262	5	SCREW,MACHINE:6-32 X 0.250,PNH,STL,T-15	0KB01	ORDER BY DESC
	211-0722-XX	J310263		4	SCREW,MACHINE:6-32 X 0.250,PNH,STL,T-15	0KB01	ORDER BY DESC
-5	129-1051-XX			2	SPACER,POST:12.5 MM L,W/4-40 INT THD	80009	129-1051-XX
-6	334-8861-XX			1	MARKER,IDENT:MKD CH1 & CH2,POLYCARB	80009	334-8861-XX
-7	129-1443-XX			2	SPACER,POST:0.98L,M3.5 INT/6-32 EXT,SWTL	80009	129-1443-XX
-8	337-3875-XX			1	SHIELD,ELEC:REAR,CH1,BRS	80009	337-3875-XX
-9	344-0472-XX			1	CLIP,CABLE:NYLON,GRAY	80009	344-0472-XX
-10	252-0571-33			1	PLASTIC SHEET:EXTR CHAN,5MM X 3.3MM,NYL	80009	252-0571-XX
-11	342-0302-XX			1	INSULATOR,FILM:CHASSIS,MYLAR	80009	342-0302-XX
-12	343-1639-00			3	CLAMP,CABLE:9-13MM ID,NYLON W/CUSHION	TK0191	343-1639-00
-13	337-3983-XX	J300101	J310xxx	1	SHIELD,ELEC:FDD,AL	TK0191	337-3983-XX
	337-4088-XX	J310xxx		1	SHIELD,ELEC:FDD,AL	TK0191	337-4088-XX
-14	407-4643-00			1	BRACKET,FDD,STL	80009	407-4693-00
-15	348-1276-00			2	GASKET,SHIELD:CONDUCTIVE FORM STRIP	80009	348-1276-XX
-16	119-4404-XX	J300101	J310xxx	1	DISK DRIVE:FLOPPY,3.5 INCH W/INTERFACE (U950)	80009	119-4404-XX
	119-5953-XX	J310xxx		1	DISK DRIVE:FLOPPY,3.5 INCH W/INTERFACE (U950)	80009	119-5953-XX
-17	105-1081-00			1	BRACKET,SPACER	TK1163	105-1081-XX
-18	211-1032-00			1	SCREW,MACHINE:M2.6 X 8MM L,PNH,STL,,MFZN-D,CROSS REC	TK0191	211-1032-XX
-19	211-1033-00			3	SCREW,MACHINE:M2.6 X 3MM L,PNH,STL,,MFZN-D,CROSS REC	TK0191	211-1033-XX
-20	211-0325-XX			4	SCR,ASSEM WSHR:4-40 X 0.250,PNH,STL,T-9	0KB01	ORDER BY DESC
-21	671-3072-XX			1	CIRCUIT BD ASSY:BACKPLANE (A5)	TK0191	671-3072-XX
-22	146-0055-XX			1	BATTERY,DRY:3.0V,1200 MAH,LITHIUM (A5BT001)	61058	BR-2/3A-E2P
-23	252-0571-XX			1	PLASTIC SHEET:EXTR CHAN,5MM X 3.3MM	80009	252-0571-XX
-24	337-4030-XX			1	SHIELD,ELEC:CENTER,ALUM	80009	337-4030-XX
-25	211-0373-XX			6	SCREW,MACHINE:4-40 X 0.250,PNH,STL,T-10	0KB01	211-0373-XX
-26	343-1084-XX			1	CLAMP,CABLE:NYLON	80009	343-1084-XX
-27	348-0948-XX			2	GROMMET,PLASTIC:BLACK,RING,9.5MM ID	80009	348-0948-XX
-28	671-2327-XX			1	CIRCUIT BD ASSY:ANALOG CH1 (A3)	80009	671-2327-XX
-29	671-2328-XX			1	CIRCUIT BD ASSY:POWER (A4)	80009	671-2328-XX
-30	211-0722-XX			8	SCREW,MACHINE:6-32 X 0.250,PNH,STL,T-15	0KB01	ORDER BY DESC
-31	252-0571-XX			1	PLASTIC SHEET:EXTR CHAN,5MM X 3.3MM,NYL	80009	252-0571-XX

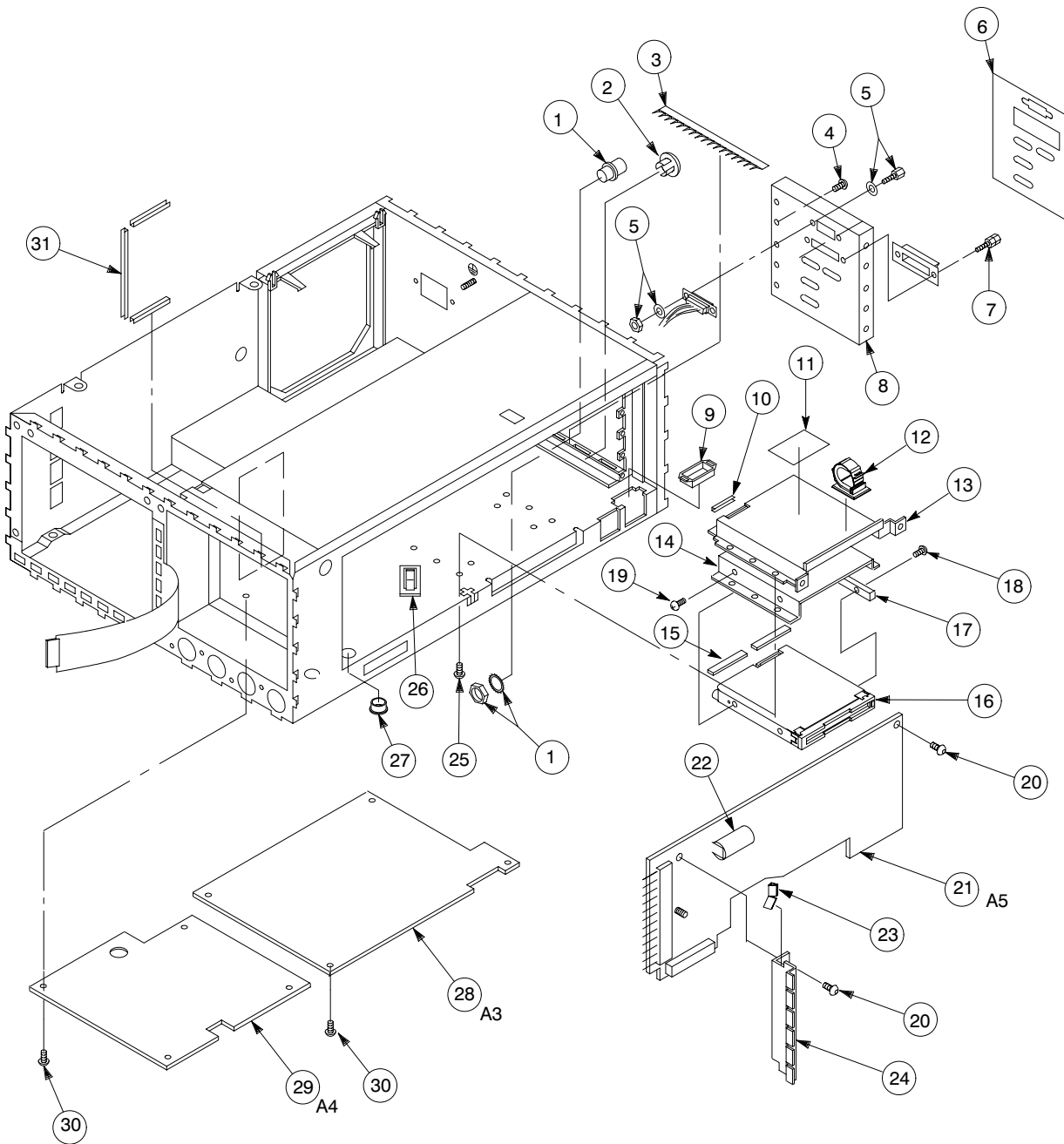

Figure 10-3: Main Chassis and Circuit Boards

Replaceable Parts List

Fig. & Index Number	Tektronix Part Number	Serial No. Effective	Serial No. Discont'd	Qty	Name & Description	Mfr. Code	Mfr. Part Number
10-4-1	671-3457-XX			1	CKT BD ASSY:CPU (A6)	80009	671-3457-XX
-2	163-0245-XX			1	IC, MEMORY:CMOS, EPROM:256K X 16,100NS (A6U305)	80009	163-0245-XX
-3	163-0244-XX			1	IC, MEMORY:CMOS, EPROM:256K X 16,100NS (A6U300)	80009	163-0244-XX
-4	131-5165-XX			1	CONN, RIBBON::PCB, FEMALE, RTANG (A6J40)	00779	555139-1
-5	333-4136-XX	J300100	J310262	1	PANEL, REAR:FLOATING PROCESSOR BD, BRASS	TK0191	333-4136-XX
-6	211-0722-XX			5	SCREW, MACHINE:6-32 X 0.250, PNH, STL, T-15	0KB01	ORDER BY DESC
-7	671-3455-XX	J300100	J310558	1	CKT BD ASSY:CONTROL CH1 (A21)	80009	671-3455-XX
	671-3850-XX	J310559	J320100	1	CKT BD ASSY:CONTROL CH1 (A21)	80009	671-3850-XX
	671-4247-XX	J320101		1	CKT BD ASSY:CONTROL CH1 (A21)	80009	671-4247-XX
-8	337-3890-XX			3	SHIELD, ELEC:EMI, SMA, COPPER	80009	337-3890-XX
-9	211-0001-XX			6	SCREW, MACHINE:2-56 X 0.25, PNH, STL	TK0435	ORDER BY DESC
-10	131-5524-XX			3	CONN, RF JACK:SMA, 50 OHM, FEMALE (A10J360, A21J410, A21J474)	80009	131-5524-XX
-11	348-1324-XX			1	GSKT, SHLD, ELEK:3.0MM DIA, SILICON, RUBBER	80009	348-1324-XX
-12	386-6158-XX			1	SUPPORT, CKT BD:MAT MATERIAL	80009	386-6158-XX
-13	210-0001-XX			3	WASHER, LOCK:#2 INTL, 0.013 THK, STL	78189	1202-00-00-0541
-14	210-0259-XX			3	TERMINAL, LUG:0.099 ID, LOCKING, BRS	TK1572	ORDER BY DESC
-15	210-0405-XX			6	NUT, PLAIN, HEX:2-56 X 0.188, BRS	73743	12157-50
-16	333-3976-XX			1	PANEL, REAR:AL	TK0191	333-3976-XX
-17	671-3459-XX			1	CKT BD ASSY:SYNTHESIZER (A10)	80009	671-3459-XX
-18	343-1535-XX			2	CABLE CLAMP:POLYVINYL	80009	343-1535-XX

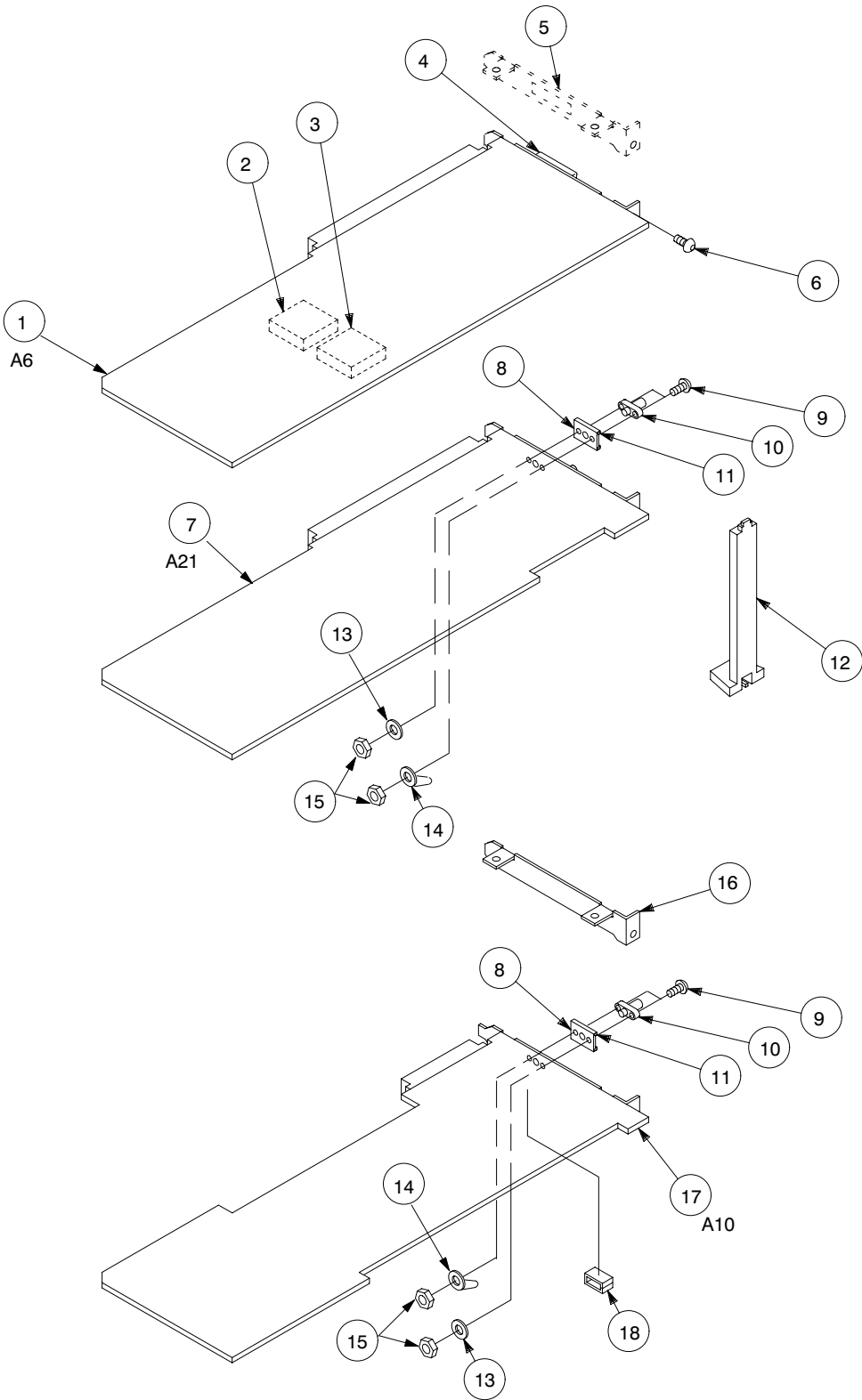

Figure 10-4: Circuit Boards

Replaceable Parts List

Fig. & Index Number	Tektronix Part Number	Serial No. Effective	Serial No. Discont'd	Qty	Name & Description	Mfr. Code	Mfr. Part Number
10-5-1	671-2520-XX			1	CIRCUIT BD ASSY:KEYBOARD (A12)	TK0191	671-2520-XX
-2	213-0048-XX			1	SETSCREW:4-40 X 0.125,STL	TK0392	ORDER BY DESC
-3	260-2497-XX			1	SWITCH,ROTARY:ENCODER (A12S103)	80009	260-2497-XX
-4	384-1686-XX			1	EXTENSION SHAFT:0.790 L X 0.500 DIA,PLASTIC	80009	384-1686-XX
-5	160-7853-XX			1	IC,PROCESSOR:CMOS,MICROCOMPUTER (A12U101)	80009	160-7853-XX
-6	210-0413-XX			2	NUT,PLAIN,HEX:0.375-32 X 0.5,BRS	73743	3145-402
-7	210-0840-XX			1	WASHER,FLAT:0.39 ID X 0.562 OD X 0.02,STL	86928	ORDER BY DESC
-8	348-1276-XX			1	GASKET,SHIELD:CONDUCTIVE FORM STRIP	80009	348-1276-XX
-9	131-1315-XX			1	CONN,RF JACK:BNC/PNL,;50 OHM,FEMALE (J970)	24931	28JR306-1
-10	366-2159-XX			1	KNOB:IVORY GRAY,SCROLL,1.243 X 1.4 X 0.4 H	TK1163	ORDER BY DESC
-11	213-0153-XX			1	SETSCREW:5-40 X 0.125,STL	TK0392	ORDER BY DESC
-12	333-4157-XX			1	PANEL,FRONT:MAIN KEY,POLYCARBONATE	80009	333-4157-XX
-13	337-3962-XX	J300101	J310313	1	SHIELD,ELEC:FRONT PANEL,EMI,AL FOIL	TK0191	337-3962-XX
-14	380-1060-XX			1	HOUSING,SWITCH:POLYCARBONATE	80009	380-1060-XX
-15	260-2552-XX			1	SWITCH,PUSH:50 BUTTON,SP/ST	80009	260-2552-XX
-16	366-2163-XX			34	PUSH BUTTON:IVORY GRAY,OVAL	80009	366-2163-XX

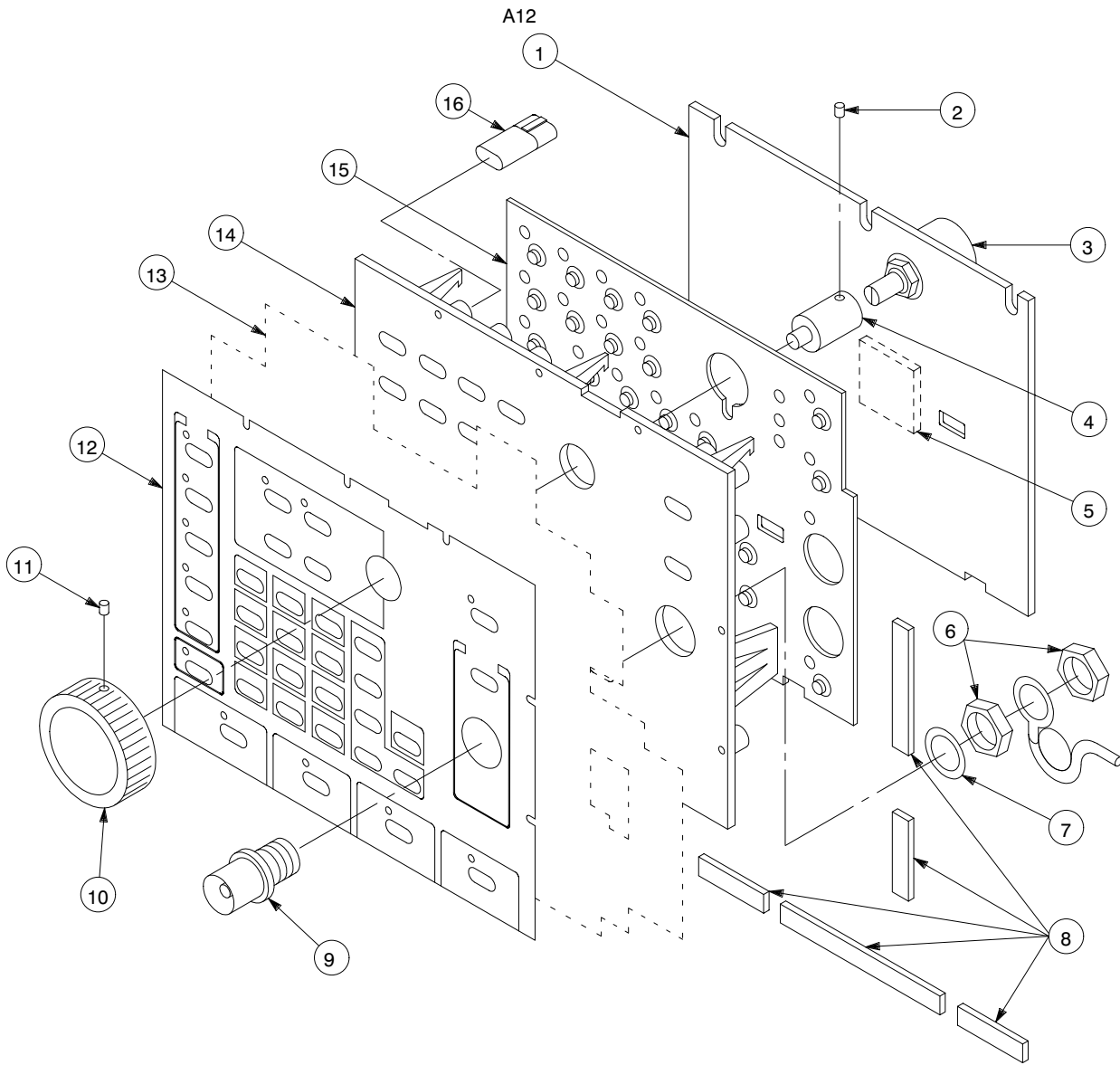

Figure 10-5: Front Panel Assembly

Replaceable Parts List

Fig. & Index Number	Tektronix Part Number	Serial No. Effective	Serial No. Discont'd	Qty	Name & Description	Mfr. Code	Mfr. Part Number
OPTION 02							
10-6-1	131-0955-XX			2	CONN,RF JACK:BNC,;50 OHM,FEMALE (J811,J821)	K1072	G35152BN
-2	211-0001-XX			2	SCREW,MACHINE:2-56 X 0.25,PNH,STL	TK0435	ORDER BY DESC
-3	131-5524-XX			1	CONN,RF JACK:SMA,;50 OHM,FEMALE (A31J410)	80009	131-5524-XX
-4	337-3890-XX			1	SHIELD,ELEC:EMI,SMA,COPPER	80009	337-3890-XX
-5	348-1324-XX			1	GSKT,SHLD,ELEK:3.0MM DIA,SILICON,RUBBER	80009	348-1324-XX
-6	210-0259-XX			1	TERMINAL,LUG:0.099 ID,LOCKING,BRS	TK1572	ORDER BY DESC
-7	210-0001-XX			1	WASHER,LOCK:#2 INTL,0.013 THK,STL	78189	1202-00-00-0541
-8	210-0405-XX			2	NUT,PLAIN,HEX:2-56 X 0.188,BRS	73743	12157-50
-9	671-3456-XX	J300100	J310558	1	CKT BD ASSY:CONTROL CH2 (A31)	80009	671-3456-XX
	671-3851-XX	J310559	J320100	1	CKT BD ASSY:CONTROL CH2 (A31)	80009	671-3851-XX
	671-4255-XX	J320101		1	CKT BD ASSY:CONTROL CH2 (A31)	80009	671-4255-XX
-10	210-0255-XX			2	TERMINAL,LUG:0.391 ID,LOCKING,BRS	TK1572	ORDER BY DESC
-11	131-1315-XX			1	CONN,RF JACK:BNC/PNL,;50 OHM,FEMALE (J852)	24931	28JR306-1
-12	671-2661-XX			1	CIRCUIT BD ASSY:ANALOG CH2 (A23)	80009	671-2661-XX
-13	211-0722-XX			4	SCREW,MACHINE:6-32 X 0.250,PNH,STL,T-15	0KB01	ORDER BY DESC

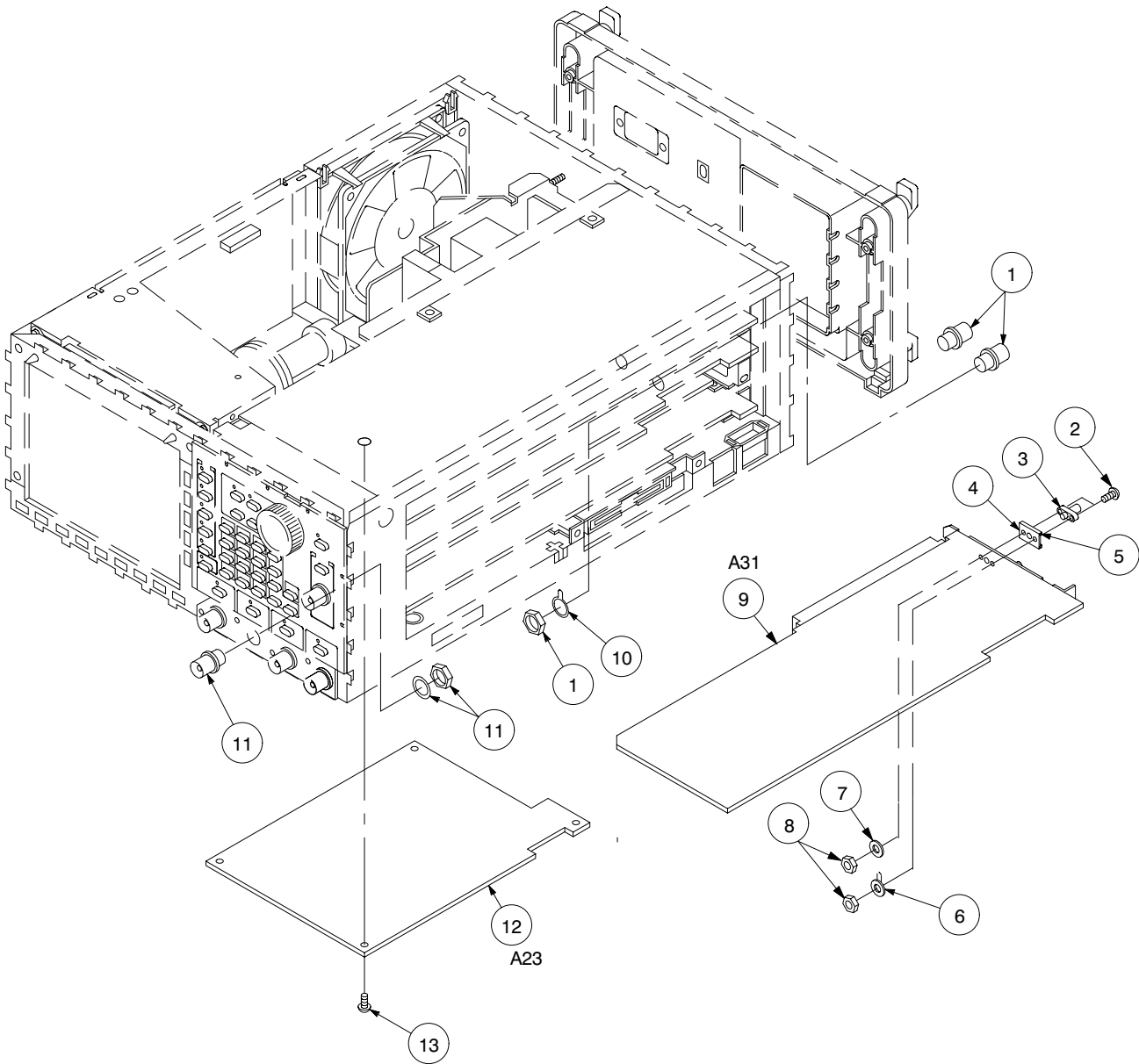

Figure 10-6: Option 02

Replaceable Parts List

Fig. & Index Number	Tektronix Part Number	Serial No. Effective	Serial No. Discont'd	Qty	Name & Description	Mfr. Code	Mfr. Part Number
OPTION 03							
10-7-1	337-4028-XX			1	SHIELD,ELEC:REAR,ECL DIGITAL DATA OUT,BRS	80009	337-4028-XX
-2	131-5566-XX			1	CONN,RIBBON:PCB,;FEMALE,RTANG,68 POS (A9J150)	80009	131-5566-XX
-3	334-8857-XX			1	MARKER,IDENT:MKD ECL DIGITAL DATA OUT	80009	334-8857-XX
-4	348-1368-XX			2	GASKET,SHIELD:FINGER TYPE,BE-CU	80009	348-1368-XX
-5	671-2497-XX	J300100	J310558	1	CKT BD ASSY:DIGITAL DATA OUT (A9)	80009	671-2497-XX
	671-3849-XX	J310559		1	CKT BD ASSY:DIGITAL DATA OUT (A9)	80009	671-3849-XX

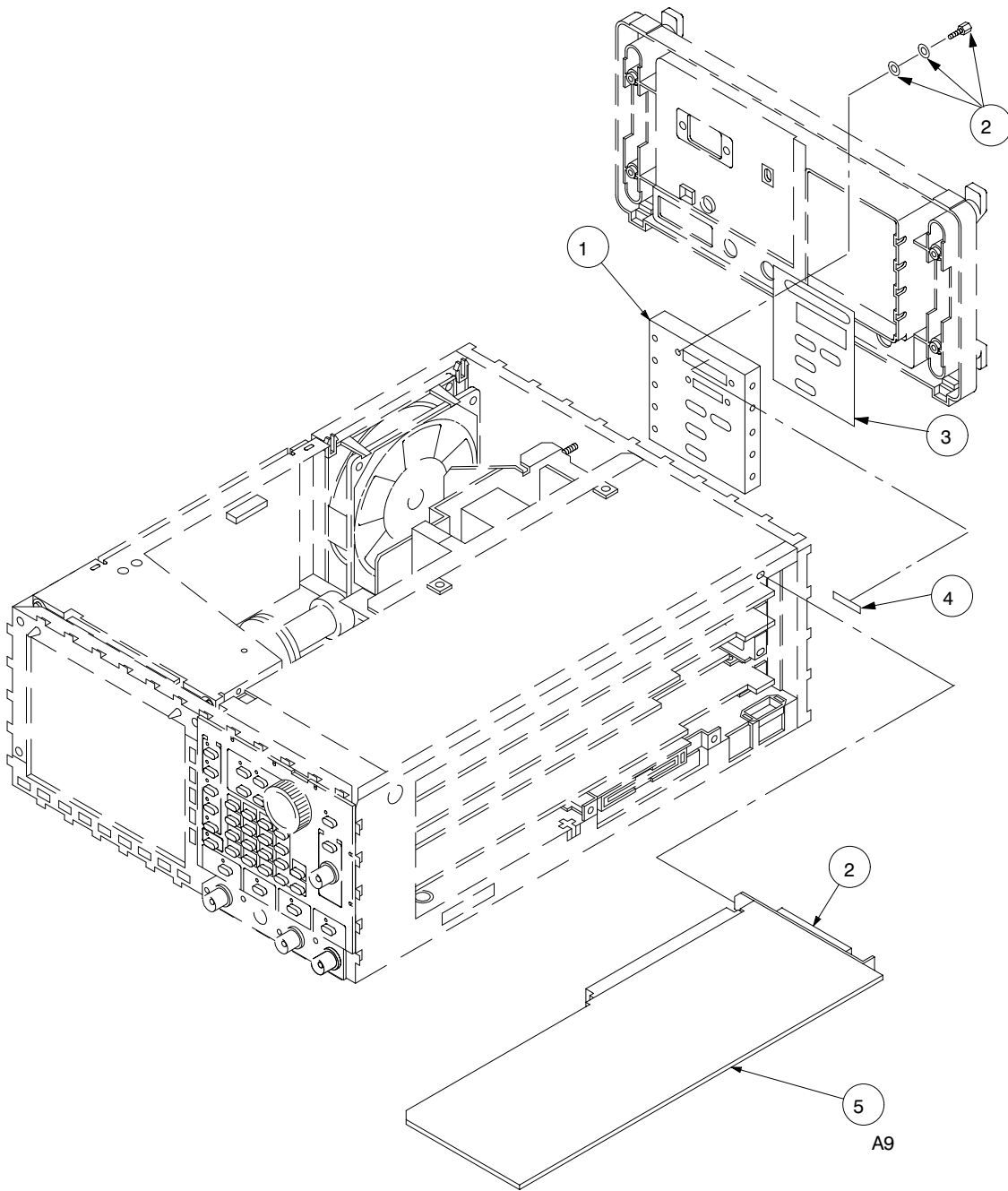

Figure 10-7: Option 03

Replaceable Parts List

Fig. & Index Number	Tektronix Part Number	Serial No. Effective	Serial No. Discont'd	Qty	Name & Description	Mfr. Code	Mfr. Part Number
OPTION 04							
10-8-1	337-4029-XX			1	SHIELD,ELEC:REAT,TTL DIGITAL DATA OUT,BRS	80009	337-4029-XX
-2	334-8858-XX			1	MARKER,IDENT:MKD TTL DIGITAL DATA OUT	80009	334-8858-XX
-3	131-5778-XX			2	CONN,HDR:PCB,;MALE,RTANG,2X13,0.1 CTR	TK0191	131-5778-XX
-4	671-3458-XX			1	CKT BD ASSY:A25,TTL DIGITAL DATA OUT (A25)	80009	671-3458-XX

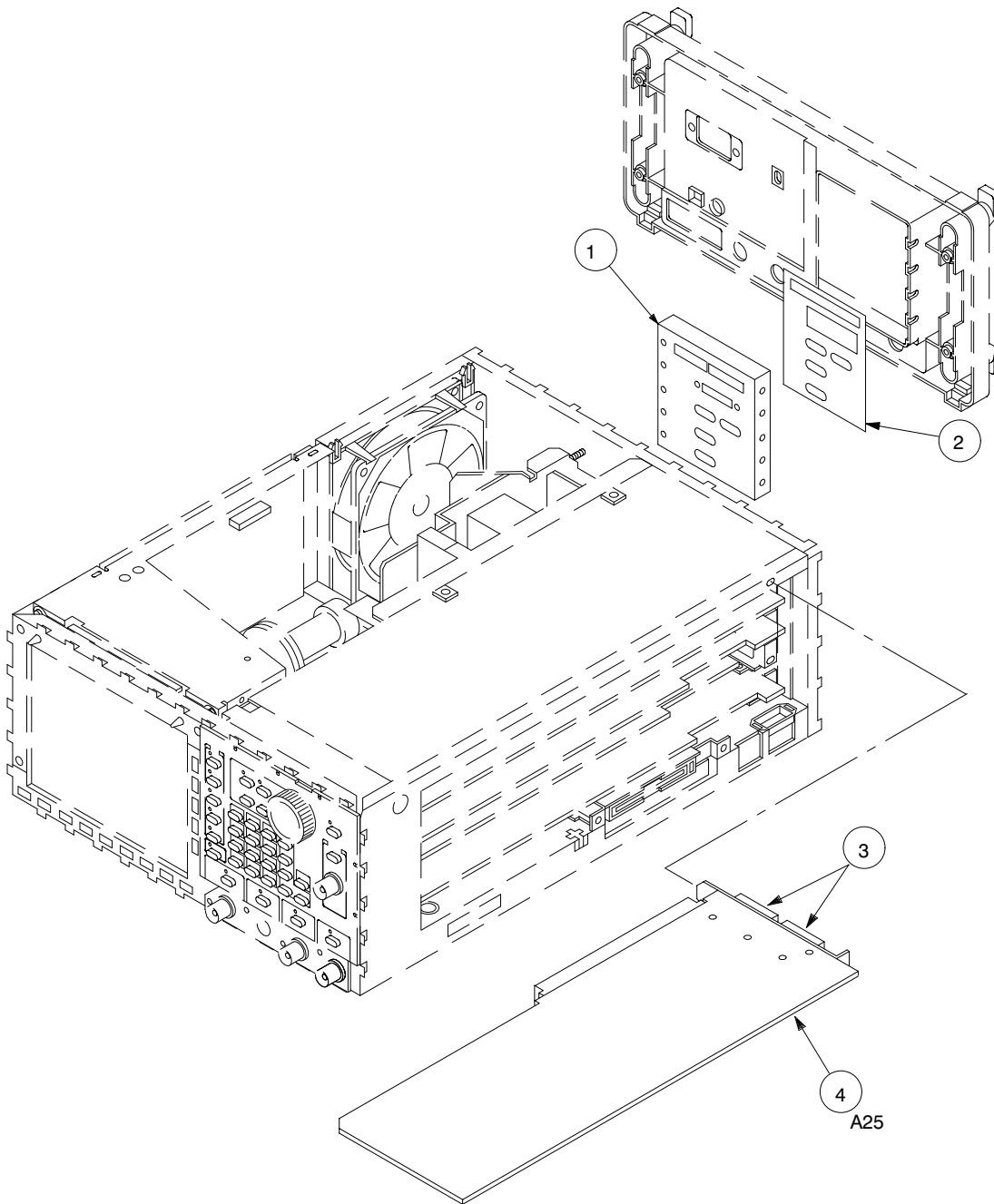

Figure 10-8: Option 04

Replaceable Parts List

Fig. & Index Number	Tektronix Part Number	Serial No. Effective	Serial No. Discont'd	Qty	Name & Description	Mfr. Code	Mfr. Part Number
OPTION 09							
10-9-1	671-3179-XX			1	CIRCUIT BD ASSY:FLOATING PROCESSOR (A7)	TK0191	671-3179-XX

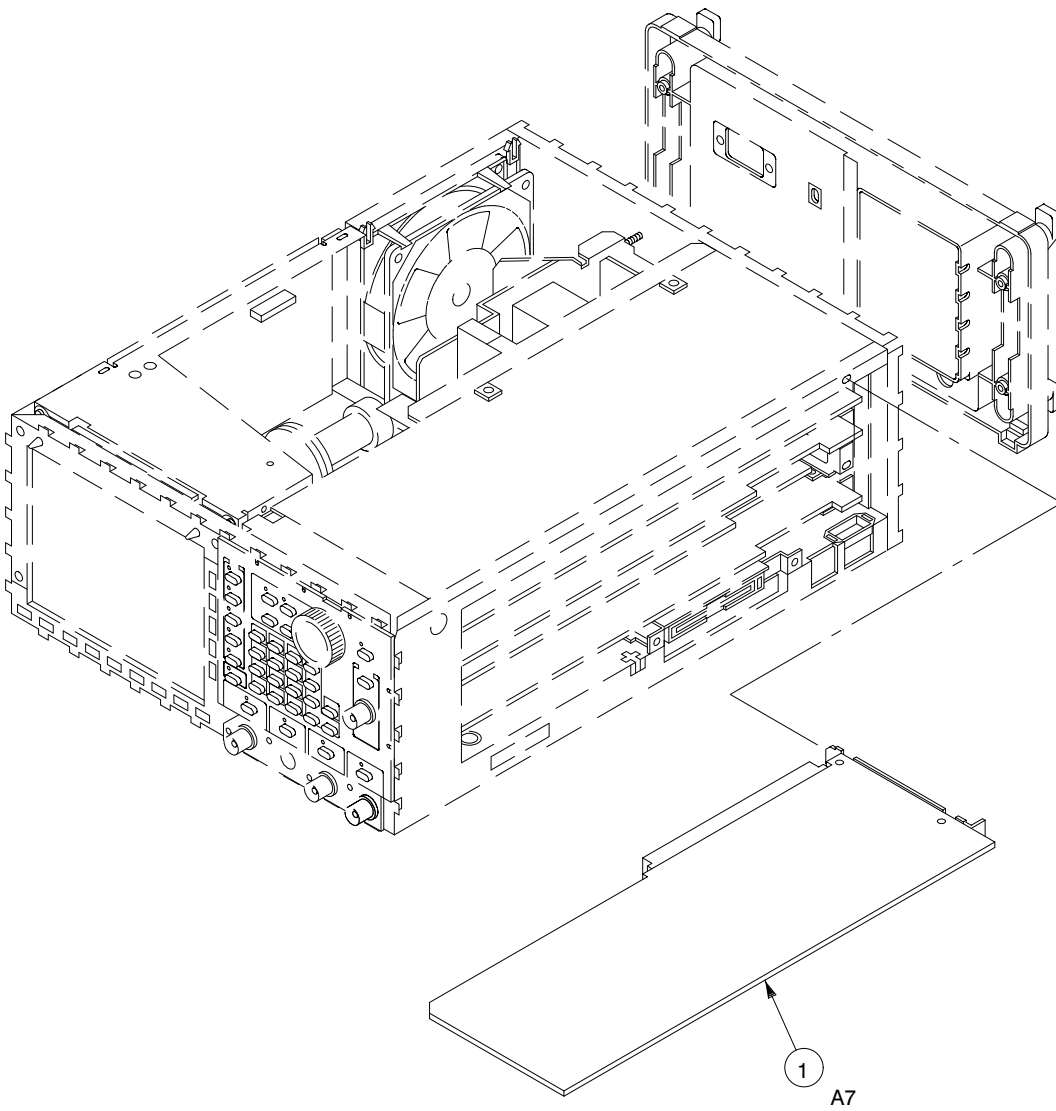

Figure 10-9: Option 09

Component Number	Tektronix Part No.	Serial No.	Effective Dscont	Name & Description	Mfr. Code	Mfr. Part No.
W1	174-2934-XX			CA ASSY,SP,ELEC:3,18 AWG,18CM L	80009	174-2934-XX
W3	196-3388-XX			LEAS,ELECTRICAL:18 AWG,12CM L,5-4	80009	196-3388-XX
W4	174-2935-XX	J300101	J310337	CA ASSY,SP,ELEC:2.18 AWG,12CM L,W/CONN	80009	174-2935-XX
	174-2803-XX	J310338		CA ASSY,SP,ELEC:2.18 AWG,12CM L,W/FSTN	80009	174-2803-XX
W6	174-2971-XX			CA ASSY,SP,ELEC:22,18 AWG,10CM L	80009	174-2971-XX
W7	196-3389-XX			LEAS,ELECTRICAL:18 AWG,15CM L,5-4	80009	196-3389-XX
W9	174-2953-XX			CA ASSY,SP,ELEC:5,26 AWG,24CM L,RIBBON	80009	174-2953-XX
W10	174-2936-XX			CA ASSY,SP,ELEC:5,26 AWG,26CM L,RIBBON	80009	174-2936-XX
W100	174-2931-XX			CA ASSY,SP,ELEC:10,26 AWG,11CM L,RIBBON	80009	174-2931-XX
W110	174-2932-XX	J300101	J310532	CA ASSY,SP,ELEC:10,26 AWG,22CM L,RIBBON	80009	174-2932-XX
	174-2801-XX	J310533		CA ASSY,SP,ELEC:10,26 AWG,22CM L,RIBBON	80009	174-2801-XX
W120	174-2946-XX			CA ASSY,SP,ELEC:10,26 AWG,33CM L,RIBBON (OPTION 02 ONLY)	80009	174-2946-XX
W150	174-3422-XX			CABLE ASSY,RF:3,500 OHM COAX,32CM L,9-2	80009	174-3422-XX
W151	174-2938-XX			CABLE ASSY,RF:50 OHM COAX,42CM L,9-1	80009	174-2938-XX
W152	174-2947-XX			CABLE ASSY,RF:50 OHM COAX,42CM L,9-2 (OPTION 02 ONLY)	80009	174-2947-XX
W153	174-2955-XX			CABLE ASSY,RF:50 OHM COAX,32CM L,9-1	80009	174-2955-XX
W155	174-3422-XX			CABLE ASSY,RF:3,500 OHM COAX,32CM L,9-2 (OPTION 02 ONLY)	80009	174-3422-XX
W158	174-2956-XX			CABLE ASSY,RF:50 OHM COAX,32CM L,9-2 (OPTION 02 ONLY)	80009	174-2956-XX
W160	174-2947-XX			CABLE ASSY,RF:50 OHM COAX,42CM L,9-2 (OPTION 02 ONLY)	80009	174-2947-XX
W170	174-2939-XX			CABLE ASSY,RF:50 OHM COAX,12CM L,9-1	80009	174-2939-XX
W204	174-3421-XX			CA ASSY,SP,ELEC:30.30AWG,60CM L,FLAT (OPTION 03 ONLY)	80009	174-3421-XX
W210	174-2940-XX			CABLE ASSY,RF:50 OHM COAX,37CM L,9-1	80009	174-2940-XX
W220	174-2940-XX			CABLE ASSY,RF:50 OHM COAX,37CM L,9-2 (OPTION 02 ONLY)	80009	174-2940-XX
W300	174-2952-XX			CA ASSY,SP,ELEC:5,26 AWG,30CM L,RIBBON	80009	174-2952-XX
W301	174-2941-XX			CABLE ASSY,RF:50 OHM COAX,17CM L,9-1	80009	174-2941-XX
W310	174-2942-XX			CABLE ASSY,RF:50 OHM COAX,23CM L,9-0	80009	174-2942-XX
W321	174-2943-XX			CABLE ASSY,RF:50 OHM COAX,46CM L,9-1	80009	174-2943-XX
W322	174-2951-XX			CABLE ASSY,RF:50 OHM COAX,17CM L,9-3 (OPTION 02 ONLY)	80009	174-2951-XX
W362	174-2944-XX			CABLE ASSY,RF:50 OHM COAX,32CM L,9-1	80009	174-2944-XX
W400	174-2954-XX			CA ASSY,SP,ELEC:5,26 AWG,15CM L,RIBBON (OPTION 02 ONLY)	80009	174-2954-XX
W630	174-2933-XX			CA ASSY,SP,ELEC:5,26 AWG,15CM L,RIBBON	80009	174-2933-XX
W664	174-2945-XX			CA ASSY,SP,ELEC:10,26 AWG,23CM L,RIBBON	80009	174-2945-XX
W675	174-2775-XX			CA ASSY,SP,ELEC:26,350MM L,FLAT FLEX	80009	174-2775-XX
W900	174-2770-XX			CA ASSY,SP,ELEC:10,26 AWG,390MM L,RIBBON	80009	174-2770-XX
W1110	174-3239-XX			CA ASSY,SP:30,30 AWG,80CM L,FLAT (OPTION 04 ONLY)	TK0191	174-3239-XX
W1210	174-3239-XX			CA ASSY,SP:30,30 AWG,80CM L,FLAT (OPTION 04 ONLY)	TK0191	174-3239-XX

Fig. & Index No.	Tektronix Part No.	Serial No. Effective Dscont	Qty	12345 Name & Description	Mfr. Code	Mfr. Part No.
STANDARD ACCESSORIES						
063-2169-XX			1	SOFTWARE PKG:3.5 INCH DISK,WAVEFORM	80009	063-2169-XX
063-1708-XX			1	SOFTWARE PKG:3.5 DISK,AWG2000 SERIES	TK0191	063-1708-XX
063-2171-XX			1	SOFTWARE PKG:3.5 IN DISK.ADJ/PERF CHECK	80009	063-2171-XX
070-9097-XX			1	MANUAL,TSCH:USER,AWG2021,DP	TK2548	070-9097-XX
070-8657-XX			1	MANUAL,TECH:PROGRAMMER	TK2548	070-8657-XX
012-1408-XX			1	CA ASSY,INTCON:SHLD CMPST,;MLD,68,28 AWG (OPTION 03 ONLY)	80009	012-1408-XX
174-3192-XX			2	CA ASSY,SP:13,COAX,50 OHM,FLAT (OPTION 04 ONLY)	TK0191	174-3192-XX
-----			1	CABLE ASSY,PWR,;3,18 AWG,92 L,SVT,TAN (SEE FIGURE 2-1)		
161-0104-05			1	CA ASSY,PWR:3,1.0MM SQ,250V/10A,2.5 METER (OPTION A3, AUSTRALIAN)	S3109	198-010
161-0104-06			1	CA ASSY,PWR:3,1.0MM SQ,250V/10A,2.5 METER (OPTION A1, EUROPEAN)	S3109	198-010
161-0104-07			1	CA ASSY,PWR:3,1.0MM SQ,240V/10A,2.5 METER (OPTION A2, UNITED KINGDOM)	S3109	209010
161-0104-08			1	CA ASSY,PWR:3,18 AWG,250/10A,98 INCH L (OPTION A4, NORTH AMERICAN)	2W733	ORDER BY DESC
161-0167-00			1	CA ASSY,PWR:3,0.75MM SQ,250V/10A,2.5 METER (OPTION A5, SWITZERLAND)	S3109	ORDER BY DESC
OPTIONAL ACCESSORIES						
011-0049-XX			1	TERMN,COAXIAL:50 OHM,2W,BNC	64537	T132DS
012-0991-XX			1	CABLE,INTCON:SHLD CMPST,GPIB;CRC	6D224	81190-020
012-1256-XX			1	CABLE,INTCON:50 OHM COAX,98.0 L	TK0BD	7220369010
012-1342-XX			1	CA ASSY,RF:COAXIAL,;RFD,50 OHM,24 L	80009	012-1342-XX
015-0554-XX			1	ADPTR,SMA,ELEC:FEMALE BNC TO MALE SMA	24931	29JP170-1
016-1154-XX			1	HOOD ASSEMBLY:	80009	016-1154-XX
016-1159-XX			1	POUCH:POUCH & PLATE,GPS SIZE	80009	016-1159-XX
067-1396-XX			1	FIXTURE,CAL:	TK0191	067-1396-XX
070-9098-XX			1	MANUAL,TECH:SERVICE,AWG2021,DP	80009	070-9098-XX
159-0239-XX			1	FUSE,CARTRIDGE:3AG,6A,250V,MEDIUM	80009	159-0239-XX
159-0210-XX			1	FUSE,CARTRIDGE:DIN 5 X 20MM,5AMP	61857	ET 5 AMP
200-2264-XX			1	CAP,FUSEHOLDER:3AG FUSES (FOR 159-0239-XX)	61935	FEK 031 1666
200-2265-XX			1	CAP,FUSEHOLDER:5 X 20MM FUSES (FOR 159-0210-XX)	61935	FEK 031.1663
200-3232-XX			1	COVER,FRONT:ASB	TK1908	PER TEK DRAWING
671-2957-XX			1	CIRCUIT BD ASSY:DIGITAL DATA OUT TERMINAL (OPTION 03 ONLY)	80009	671-2957-XX
131-3847-XX			1	CONN,RCPT,ELEC:HEADER,2 X 13,0.1 SPACING (OPTION 04 ONLY)	80009	131-3847-XX

